

**Pre-Standard for
Load & Resistance Factor
Design (LRFD) of Pultruded
Fiber Reinforced Polymer (FRP)
Structures
(Final)**

**Submitted to:
American Composites Manufacturers
Association (ACMA)**

November 9, 2010



DISCLAIMER

Statements expressed in this document do not necessarily represent the views of ASCE, which takes no responsibility for any statement made herein. No reference made in this publication to any specific method, product, process or service constitutes or implies an endorsement, recommendation, or warranty thereof by ASCE. The material is for general information only and does not represent a standard of ASCE, nor is it intended as a reference in purchase specifications, contracts, regulations, or any other legal document.

ASCE makes no representation or warranty of any kind, whether express or implied, concerning the accuracy, completeness, suitability, or utility of any information, apparatus, product, or process discussed in this publication, and assumes no liability therefore. This information should not be used without first securing competent advice with respect to its suitability for any general or specific application. Anyone utilizing this information assumes all liability arising from such use, including but not limited to infringement of any patent or patents.

Although the information in this document has been funded wholly or in part by the American Composites Manufacturers Association (ACMA), it may not necessarily reflect the views of the organization and no official endorsement should be inferred.

RESTRICTIONS

The information in this document is intended solely for use in the development of an ASCE Pre-Standard for Load and Resistance Factor Design (LRFD) for Pultruded Fiber Reinforced Polymer (FRP) Structures. Any modifications and/or use or reproduction for other purposes is prohibited.

PREFACE

This preface is not part of *SEI/ASCE Pre-Standard for Load and Resistance Factor Design (LRFD) of Pultruded Fiber Reinforced Polymer (FRP) Structures*, but is included for purposes of information only.

This Pre-Standard for load and resistance factor design of structures using pultruded fiber-reinforced polymer shapes is based on the current state of knowledge regarding the behavior of FRP structures and recommended design practices. It was developed using principles of probability-based limit states design to provide uniform practice in the design of FRP structural systems. The design criteria herein are suitable for most applications encountered on a routine basis in professional practice, but the criteria may not be applicable to infrequently encountered designs, for which professional judgment must be exercised.

The Symbols and Glossary to this Pre-Standard are an integral part of the Pre-Standard. A non-mandatory commentary has been prepared to provide background for the Standard and to assist in the proper interpretation of its provisions.

Those using this LRFD standard assume all liability arising from its use. The design of engineered structures is within the scope of expertise of licensed engineers, architects, or other licensed professionals for applications to a particular structure. The user is cautioned that professional judgment must be exercised when data or recommendations in this Standard are applied. Particular attention is directed to the designer's responsibility to make adjustments for particular end-use conditions. It is intended that the Pre-Standard be used in conjunction with competent engineering design, accurate fabrication and adequate supervision of construction.

The provisions were developed by a project team consisting of structural engineers and FRP material experts with broad experience and high professional standing. The following individuals had primary responsibility for the individual chapters:

- Chapter 1. General Provisions – Bruce R. Ellingwood
- Chapter 2. Design Requirements – Bruce R. Ellingwood
- Chapter 3. Design of Tension Members – Hota V.S. GangaRao
- Chapter 4. Design of Compression Members – Abdul-Hamid Zureick
- Chapter 5. Design of Members for Flexure and Shear – Lawrence Bank
- Chapter 6. Design of Members Under Combined Forces and Torsion - Hota V.S. GangaRao
- Chapter 7. Design of Plates and Built-Up Members – Roberto Lopez-Anido
- Chapter 8. Design of Bolted Connections – J. Toby Mottram

Symbols and Notations – Mehdi S. Zarghamee, Bruce R. Ellingwood
Glossary – Bruce R. Ellingwood, Mehdi S. Zarghamee

ACKNOWLEDGEMENTS

American Society of Civil Engineers (ASCE) gratefully acknowledges the contribution of individuals whose efforts helped develop the content of this Pre-Standard. Notably, this Pre-Standard is based on work conducted by the following Project Team (PT) members who took the lead in carrying out the objectives of this project, and provided invaluable contribution in authoring this Pre-Standard:

- Bruce R. Ellingwood, Georgia Institute of Technology
- Hota V. S. GangaRao, West Virginia University
- Roberto Lopez-Anido, University of Maine
- J. Toby Mottram, Warwick University
- Abdul-Hamid Zureick, Georgia Institute of Technology
- Lawrence Bank, University of Wisconsin at Madison (supported by Russell Gentry of Georgia Institute of Technology, Carol Shield of University of Minnesota, and Michael McCarthy of University of Wisconsin)

Development of this Pre-Standard would not have been possible without the tireless efforts and invaluable technical contribution of Mehdi S. Zarghamee of Simpson Gumpertz & Heger, who served as the Project Coordinator, and was responsible for providing leadership and technical coordination to the PT throughout the course of this project.

ASCE also acknowledges the volunteer contribution of the following members of the Project Advisory Committee (PAC), who reviewed and commented on the Pre-Standard at various stages of its development, and whose efforts and suggestions significantly influenced the content of this Pre-Standard:

- Sami H. Rizkalla, North Carolina State University (Chair)
- Charles E. Bakis, Pennsylvania State University
- Ken Berg, American Grating
- Eric Johansen, E. T. Techtonics
- David Kerins, ExxonMobil Research & Engineering
- Ayman Mosallam, University of California at Irvine
- Ayman M. Okeil, Louisiana State University
- Max Porter, Iowa State University
- Dustin Troutman, Creative Pultrusions
- Tom Williamson (Retired), APA - The Engineered Wood Association
- Daniel A. Witcher, Strongwell
- Matthias Oppe, Knippers Helbig, Germany (International Liaison)
- Gaetano Manfredi, University of Naples, Italy (International Liaison)
- Thanasis C. Triantafyllou, University of Patras, Greece (International Liaison)
- Heiko Trumpf, Werner Sobek, Germany (International Liaison)

In addition, ASCE greatly appreciates the volunteer efforts of engineers from the following design firms for preparing solutions for the various design problems during the trial design phase of this Pre-Standard development project:

- Alfred Benesch & Company
- Arup
- Gilsanz Murray Steficek
- Hardesty & Hanover

- Magnusson Klemencic Associates
- Robert Silman Associates
- Severud Associates
- Walter P. Moore & Associates
- Weidlinger Associates

As this work was conducted under an agreement with the American Composites Manufacturers Association (ACMA), ASCE gratefully acknowledges ACMA's contribution to fund this project. Moreover, ASCE appreciates the efforts of John P. Busel of ACMA staff for his leadership and coordination during the course of this project. ASCE also recognizes the contribution of members of ACMA's Pultrusion Industry Council (PIC) in providing incisive and well-focused industry feedback to help keep the project moving in a constructive direction.

Among the members of its staff, ASCE extends its appreciation to Jim Rossberg for his vision and guidance on this project. In addition, ASCE extends its appreciation to Muhammad Amer for his leadership in managing this challenging project on behalf of ASCE, and for his overall support and contribution to the success of this Pre-Standard development effort.

TABLE OF CONTENTS

| | Page |
|--|-------------|
| PREFACE | iii |
| ACKNOWLEDGEMENTS | iv |
| GLOSSARY | xi |
| SYMBOLS & NOTATIONS | xvii |
| 1. GENERAL PROVISIONS | 1 |
| 1.1 Scope | 1 |
| 1.1.1 Applicability and Exclusions | 1 |
| 1.1.2 Maximum Service Temperature | 1 |
| 1.1.3 Units | 1 |
| 1.2 Referenced Specifications, Codes and Standards | 1 |
| 1.3 Materials | 3 |
| 1.3.1 FRP Constituent Materials | 3 |
| 1.3.2 Physical and Mechanical Properties of Pultruded FRP Products | 4 |
| 1.3.3 Fire, Smoke and Toxicity | 5 |
| 1.3.4 Durability and Environmental Effects | 5 |
| 1.3.5 Impact Tolerance | 6 |
| 1.4 Design Basis | 6 |
| 1.4.1 Limit States Design | 6 |
| 1.4.2 General Analysis Requirements | 6 |
| 1.4.3 Design for Strength | 7 |
| 1.4.4 Design for Serviceability | 7 |
| 1.5 Loads and Load Combinations | 7 |
| 1.5.1. Nominal Loads | 7 |
| 1.5.2 Load Combinations for Strength Limit States | 8 |
| 1.5.3 Load Combinations for Serviceability Limit States | 10 |
| 1.6 Structural Design Drawings and Specifications | 10 |
| 1.7 Fabrication, Construction and Quality Assurance | 10 |
| 1.7.1 Shop and Construction Drawings | 10 |
| 1.7.2 Fabrication and Construction | 11 |
| 1.7.3 Quality Assurance and Control | 11 |
| 2. DESIGN REQUIREMENTS | 12 |
| 2.1 Scope | 12 |
| 2.2 Properties of Sections | 12 |
| 2.3 Design Strength | 12 |
| 2.3.1 Basic Strength Requirement | 12 |
| 2.3.2 Prequalified FRP Building Products | 13 |
| 2.4 Nominal Strength and Stiffness | 14 |
| 2.4.1 Nominal Strength | 14 |
| 2.4.2. Reference Strength and Stiffness | 14 |

| | |
|---|-----------|
| 2.4.3 Statistical Basis for Reference Strength and Stiffness | 14 |
| 2.4.4 Adjustments to Reference Strength | 15 |
| 2.4.5 Notches, Holes and Other Stress Concentrations | 16 |
| 2.5 Stability of Frames and Members | 16 |
| 2.5.1 General Requirements | 16 |
| 2.5.2 Design Requirements for Frame Stability | 16 |
| 2.5.3 Required Strength of Frames | 17 |
| 2.5.4 Design Requirements for Member Stability | 18 |
| 2.5.5 Bracing of Members and Frames | 18 |
| 2.6 Design for Serviceability | 20 |
| 2.6.1 Deformations | 20 |
| 2.6.2 Vibration | 20 |
| 2.6.3 Connection Slip | 21 |
| 2.6.4 Expansion and Contraction | 21 |
| 2.6.5 Deterioration | 21 |
| 2.7 Design for Ponding | 21 |
| 2.8 Design for Fatigue | 21 |
| 2.9 Design of Connections | 22 |
| 2.10 Gross and Net Areas | 23 |
| 2.10.1 Gross Area | 23 |
| 2.10.2 Net Area | 23 |
| 2.10.3 Effective Net Area. | 23 |
| 3. DESIGN OF TENSION MEMBERS | 24 |
| 3.1 Scope | 24 |
| 3.2 General Provisions | 24 |
| 3.3 Nominal Axial Tensile Strength | 24 |
| 3.4 Built-Up Members | 25 |
| 3.5 Slenderness Limitations | 25 |
| 4. DESIGN OF COMPRESSION MEMBERS | 26 |
| 4.1 Scope | 26 |
| 4.2 General Provisions | 26 |
| 4.3 Slenderness and Effective Length Considerations | 27 |
| 4.3.1 Effective Member Length | 27 |
| 4.3.2 Effective Length Factor | 27 |
| 4.3.3 Compression Member Effective Length | 27 |
| 4.3.4 Compression Member Effective Slenderness Ratio | 27 |
| 4.4 Factored Critical Stress in Compression for Common Sections | 27 |
| 4.4.1 Geometrically Symmetric I-Shaped Sections | 28 |
| 4.4.2 T-Shaped Sections | 29 |
| 4.4.3 Single Angle Sections with Equal Legs | 30 |
| 4.4.4 Single Angle Sections with Unequal Legs | 31 |
| 4.4.5 Square and Rectangular Tube Sections | 31 |
| 4.4.6. Circular Tube Sections | 32 |
| 4.4.7 Square, Rectangular, and Circular Solid Sections | 32 |
| 4.5 Compression Strength for Members with Other Cross Sections | 33 |
| 4.6 Compression Strength for Built-up Members | 33 |
| 4.6.1 Design Strength | 33 |

| | |
|---|-----------|
| 4.6.2 Detailing Requirements | 33 |
| 5. DESIGN OF MEMBERS FOR FLEXURE & SHEAR | 34 |
| 5.1 Scope | 34 |
| 5.2 Design of Members for Flexure | 34 |
| 5.2.1 Design Basis | 34 |
| 5.2.2 Nominal Strength of a Section due to Material Rupture | 34 |
| 5.2.3 Nominal Strength of a Section due to Local Instability | 35 |
| 5.2.4 Nominal Strength of Sections due to Lateral-Torsional Buckling | 39 |
| 5.3 Design of Members for Shear | 40 |
| 5.3.1 Design Basis | 40 |
| 5.3.2 Nominal Strength of a Section due to Material Rupture in Shear | 41 |
| 5.3.3 Nominal Strength of Sections due to Web Shear Buckling | 41 |
| 5.4 Design of Sections for Concentrated Forces | 43 |
| 5.4.1 Design Basis | 43 |
| 5.4.2 Nominal Strength of a Section due to Tensile Rupture of Web(s) | 43 |
| 5.4.3 Nominal Strength of Sections due to Web Crippling | 44 |
| 5.4.4 Nominal Strength of a Section due to Web Compression Buckling | 44 |
| 5.4.5 Nominal Strength of a Section due to Flange Flexural Failure | 45 |
| 5.5 Design for Copes, Notches, Holes and Openings | 45 |
| 5.5.1 Copes, Notches, Holes and Openings in the Flange or Web | 45 |
| 5.5.2 Doubler Plate Requirements | 46 |
| 5.6 Design of Flexural Members for Serviceability | 46 |
| 6. DESIGN OF MEMBERS UNDER COMBINED FORCES & TORSION | 47 |
| 6.1 Scope | 47 |
| 6.2 Doubly and Singly Symmetric Members Subject to Flexure and Axial Force | 47 |
| 6.2.1 Doubly and Singly Symmetric Members Subject to Flexure and Compression | 47 |
| 6.2.2 Doubly and Singly Symmetric Members Subject to Flexure and Tension | 47 |
| 6.2.3 Doubly and Singly Symmetric Members Subject to Only Strong Axis Flexure and Compression | 48 |
| 6.2.4 Doubly and Singly Symmetric Members Subject to Only Strong Axis Flexure and Tension | 48 |
| 6.3 Doubly Symmetric Members under Torsion and Combined Torsion, Flexure and/or Axial Force | 49 |
| 6.3.1 Torsional Strength of Circular and Rectangular Hollow Tubes | 49 |
| 6.3.2 Rectangular Hollow Tubes Subject to Combined Torsion, Flexure and Axial Force | 51 |
| 6.3.3 Design Strength of Open Doubly Symmetric Shapes Subject to Torsion and Combined Forces | 52 |
| 7. DESIGN OF PLATES AND BUILT-UP MEMBERS | 53 |
| 7.1 Scope | 53 |
| 7.2 General Provisions | 53 |
| 7.3 Design of Plates Subjected to Flexure | 54 |
| 7.3.1 Nominal Flexural Strength of Plates for One-Way Plate Bending | 54 |
| 7.3.2 Nominal Flexural Strength of Plates for Two-Way Plate Bending | 55 |

| | |
|---|-----------|
| 7.4 Design of Plates Subjected to Through-the-Thickness Shear | 55 |
| 7.4.1 Nominal Shear Strength of Plates for One-Way Plate Bending | 55 |
| 7.4.2 Nominal Shear Strength of Plates for Two-Way Plate Bending | 56 |
| 7.4.3 Nominal Pull-Through Strength of Plates | 56 |
| 7.5 Design of Plates Subjected to In-Plane Tensile Loading | 57 |
| 7.5.1 Nominal Tensile Strength of Plates | 57 |
| 7.5.2 Nominal Strength of Plates Subjected to Longitudinal Tension | 57 |
| 7.5.3 Nominal Strength of Plates Subjected to Transverse Tension | 58 |
| 7.6 Design of Plates Subjected to In-Plane Compressive Loading | 58 |
| 7.6.1 Nominal Compressive Strength of Plates | 58 |
| 7.6.2 Nominal Material Rupture Strength of Plates Subjected to Compression | 58 |
| 7.6.3 Nominal Strength of Plates Subjected to Longitudinal Compression | 59 |
| 7.6.4 Nominal Strength of Plates Subjected to Combined Longitudinal and Transverse Compression | 60 |
| 7.7 Design of Plates Subjected to In-Plane Shear Loading | 60 |
| 7.7.1 Nominal In-Plane Shear Strength of Plates | 60 |
| 7.7.2 Nominal Material Rupture Strength of Plates Subjected to In-Plane Shear | 60 |
| 7.7.3 Nominal Buckling Strength of Plates Subjected to In-Plane Shear | 61 |
| 7.8 Design of Built-up Members | 61 |
| 7.8.1 Design Basis | 61 |
| 7.8.2 Design of Built-up Members Subjected to In-Plane Tensile Loading | 62 |
| 7.8.3 Design of Built-up Members Subjected to In-Plane Compressive Loading | 62 |
| 7.8.4 Design of Built-up Members Subjected to Through-the-Thickness Shear | 62 |
| 7.8.5 Design of Panel-Based Assemblies | 63 |
| 7.8.6 Design of Plate Girders | 64 |
| 7.8.7 Design of Shear Walls and Diaphragms | 65 |
| 7.9 Design of Decking Members | 66 |
| 7.9.1 Design Basis | 66 |
| 7.10 Design of Plates for Serviceability | 66 |
| 8. DESIGN OF BOLTED CONNECTIONS | 67 |
| 8.1 Scope | 67 |
| 8.1.1 Axially Loaded Connection Types | 67 |
| 8.1.2 Placement of Bolts | 68 |
| 8.1.3 Framing Connections | 68 |
| 8.2 General Provisions | 68 |
| 8.2.1 Scope | 68 |
| 8.2.2 Bolts | 68 |
| 8.2.3 Size and Use of Bolt Holes | 68 |
| 8.2.4 Nuts and Washers | 69 |
| 8.2.5 Connection Geometry Requirements | 69 |
| 8.3 Connection Design | 70 |
| 8.3.1 Scope | 70 |
| 8.3.2 Nominal Strength of Single Row Bolted Connections | 71 |
| 8.3.3 Nominal Strength of Bolted Connections with Two or Three Rows of Bolts | 77 |
| 8.3.4 Frame Connections | 83 |
| 8.4 Column Bases and Bearing on Concrete | 84 |
| COMMENTARY | 85 |

LIST OF TABLES

| | |
|--|----|
| Table 1.3-1 Required Physical Properties for FRP Materials | 28 |
| Table 1.3-2(a) Minimum Required Characteristic Mechanical Properties for FRP Composite Shapes | 28 |
| Table 1.3-2(b) Minimum Required Characteristic Mechanical Properties for FRP Composite Plates | 29 |
| Table 2.3-1 Time effect factors, λ | 37 |
| Table 2.4-1 Adjustment factors for end use conditions | 39 |
| Table 2.8-1 Fatigue design parameters | 46 |
| Table 8.1 Minimum requirements for bolted connection geometries | 90 |
| Table 8.2 Nominal strength of bolts | 92 |
| Table 8.3 Load distributions for multi-bolted connections with two or three bolt rows | 97 |

LIST OF FIGURES

| | |
|--|----|
| Figure 8.1 Connection geometry and definition for a row of bolts | 89 |
| Figure 8.2. Loading directions for FRP material strengths | 89 |

GLOSSARY

Fundamental definitions:

Terms in this *Standard* pertaining to FRP pultruded shapes shall be defined as in ASTM D 883 *Terminology Relating to Plastics*, ASTM D 3878 *Standard Terminology of High-Modulus Reinforcing Fibers and Their Composites*, and ASTM D 907 *Standard Terminology of Adhesives*. When definitions of terms are in conflict, definitions in ASTM D3878 shall have precedence over definitions in ASTM D883.

Additional important terms and definitions:

Acceptance test: A test, or series of tests conducted by the procuring agency, or an agent thereof, to determine whether an individual lot of materials conforms to the purchase order or contract, or to determine the degree of uniformity of the material supplied by the vendor, or both (ASTM D907).

Amplification factor: A factor that is used to multiply the results of a *first-order analysis* to reflect *second-order* effects.

Additives. Substances added to the polymer resin to aid in the processing of the FRP material.

Adhesive: A substance capable of holding materials together by surface attachment.

Applicable building code: The building code under which the structure is designed.

Authority having jurisdiction: Organization, political agency or individual with responsibility for administering and enforcing the provisions of the applicable building code.

Bearing failure: The limit state in a bolted connection involving bearing failure of the connecting elements due to shear forces transmitted by the bolt.

Block shear rupture: The limit state in a bolted connection involving tension fracture along one plane and shear fracture along another plane.

Balanced composite: A composite in which all laminae at angles other than 0° and 90° occur in +/- pairs (not necessarily adjacent).

Braced frame. A vertical truss system that provides resistance to lateral forces and stability to the structural system.

Buckling. A limit state involving a sudden change in the geometry of the structure or structural elements thereof.

Camber. Curvature that is fabricated into a beam or truss to compensate for deflections induced by gravity loads.

Characteristic value. A statistically-based property value representing the 80% lower confidence bound on the 5th-percentile value of a specified population, determined in accordance with ASTM D 7290.

Clear span. Inside distance between the faces of supports.

Components. Members and elements of FRP material used to construct a structure.

Connection. A combination of elements, fasteners and possibly adhesives, acting alone or in combination with member bearing, used to transmit forces between two or more members.

Connector. A synonym for fastener. In this pre-standard the “fastener” type is limited to bolts.

Cope. A cutout made in a structural member to remove a flange element to conform to the shape of an intersecting member.

Creep. Time dependent deformation under constant load.

Design span. For simple, continuous and cantilever beams, the clear span plus one-half the required bearing length at each support.

Design strength. Nominal resistance in end-use condition, R_n , multiplied by resistance factor, ϕ , and time effect factor, λ .

Double curvature. Flexural deformation of a beam, column or beam-column involving one or more inflection points within the span-

Drift. Lateral deformation of the structure; inter-story drift is the relative lateral displacement of a story.

Edge distance. Transverse distance between centerline of a bolt hole and the nearest edge of the member or of the connecting component measured normal to the direction of resultant force.

Effective length. Length of a column having a strength that equals that of an identical column having pinned ends.

Effective net area. Net area modified to account for shear lag.

Elastic analysis. Structural analysis based on the assumptions of small deflections and linear stress-strain relationships.

End distance. Longitudinal distance between centerline of the bolt hole and the end the member or of the connecting component measured in the direction of resultant force.

End-use conditions. The chemical and load exposure conditions to which the structure is subjected to during its service.

Engineer of Record. The licensed professional that is responsible for sealing the design documents (also denoted as Engineer)

FRP: Abbreviation for a Fiber Reinforced Polymer material that consists of a polymer resin based matrix reinforced with fibers of either glass, carbon or aramid, and hybrid combinations of these fiber types.

Factored load. Product of the nominal load and a load factor.

Fastener. Synonymous with connector.

Fatigue. A progressive development of damage due to cracking, fretting and similar effects, resulting from repeated application of loads.

Fiber: One or more filaments in the form of a continuous strand or roving in an FRP material.

Fiber Architecture: Construction of the composite from layers with different types and orientations of fibrous material.

Fiber Orientation: The orientation or alignment of the longitudinal axis of the fiber with respect to a stated reference axis.

Fiber volume fraction: The volume of reinforcement fiber in a cured composite divided by the volume of the composite section.

Fillers: Non adhesive substance added in the matrix or adhesive material to alter its engineering properties, performance, and/or cost.

First-order analysis: Structural analysis in which equilibrium conditions are formulated on the undeformed structure.

Flexural buckling: Buckling mode in which a compression member deflects laterally without twist.

Flexural-torsional buckling: Buckling mode in which a compression member bends and twists simultaneously.

Gage spacing. Transverse center-to-center spacing between fasteners.

Glass Transition Temperature (T_g): Temperature at which the polymer matrix changes from a glassy to a rubbery state.

Gravity load. Loads produced by dead, live, snow and rain loads, and other effects, acting in the downward direction.

Instability. A limit state in which a small increase in the loading acting on a member or structure or a slight disturbance in geometry produces a disproportionate large displacement.

Lamia. A layer of glass and resin

Lateral load. Loads produced by wind and earthquake effects, and other effects, acting in the lateral direction.

Lateral load-resisting system. A structural system that has been designed to resist lateral forces and to provide stability for the structure as a whole.

Lateral-torsional buckling. Limit state of buckling in a flexural member that involves deflection normal to the plane of bending accompanied by simultaneous twist about the shear center of the cross-section.

Limit state. A condition in which a structure or component thereof is judged either to be no longer useful for its intended function (serviceability limit state) or to have reached its ultimate load-carrying capacity (strength limit state).

Load duration (time effect). The period of continuous application of a load, or the cumulative period of intermittent applications of a load.

Load factor. A factor that accounts for unavoidable deviations of the actual load from the nominal load and for uncertainties in the analysis that transforms the load into a load effect.

Load and resistance factor design (LRFD). A method of proportioning structural components (members, connectors, connecting elements, and assemblages) such that the design strength equals or exceeds the required strength for all applicable limit states.

Local buckling. A limit state involving buckling of an element (flange, web, stem, plate) of a compression element within a cross-section.

Material longitudinal direction: Direction parallel to longitudinal direction of pultrusion rovings (pulling direction in manufacture).

Material resistance adjustment factor: Factors that define the resistance in the end use condition in terms of laboratory strength values.

Matrix: The continuous constituent of a FRP material that surrounds the fibers. It consists of a polymer resin with fillers and additives.

Net area. Gross area of cross section, reduced to account for removed material.

Nominal loads: The loads specified by *ASCE Standard 7-10*, *Minimum design loads for buildings and other structures* or applicable building code.

Nominal strength or nominal resistance: The strength of a structure or component in the end-use conditions (without resistance or time-effect factors applied), developed in accordance with the provisions of this *Standard*.

Notional load: A virtual lateral load applied in a structural analysis to account for potential de-stabilizing effects that are not otherwise accounted for in design.

P-delta effects: Generic term, describing the amplifying effect of loads acting on the deflected shape of a structure. $P-\delta$ effects describe the potential amplification due to the deflected shape of a member between its ends (with respect to the chord connecting the member ends). $P-\Delta$ effects describe the amplification due to loads acting on the laterally displaced locations of joints.

Performance standard: A standard for manufactured structure based on stipulated minimum performance requirements. Performance is based on tests that approximate end-use conditions.

Pultrusion: A continuous manufacturing process used to manufacture constant cross-section shapes of any length.

Qualification test: A series of tests conducted by the procuring activity, or an agent thereof, to determine conformance of materials, or materials system, to requirements of a specification which normally results in a qualified products list under the specification ASTM D 907.

Quality assurance. The administrative and procedural requirements established by the contract documents to assure that the constructed composite components and system is in compliance with applicable standards, contract documents, and manufacturer's quality control program.

Quality control: Set of activities instituted by the designer, manufacturer, or contractor intended to insure that the constructed work meets the quality requirements.

Rational engineering analysis: Analysis based on theory that is appropriate for the situation, relevant test data if available, and sound engineering judgment.

Reference strength: Material strength (tension, flexure, compression, and shear) of a member or connection determined using standard test methods, as stipulated in this standard.

Reference stiffness: Material stiffness of a member or connection using standard test methods, as stipulated in this standard.

Relaxation: Time-dependent reduction in stress under a constant strain.

Required strength: The load effect or structural action (force, moment, or stress) acting on a structural system, member or connection, as determined by structural analysis from the factored loads, considered in appropriate combinations.

Resin: An organic polymer possessing indefinite and often high molecular weight and a softening or melting range that exhibits a tendency to flow when subjected to stress.

Resistance: Generic term describing the capacity of a structure, component or connection to withstand the effects of load; determined from specified material strengths, stiffnesses, dimensions and formulas derived from accepted principles of structural mechanics or by field or from laboratory tests of scaled models, allowing for modeling effects and differences between laboratory and field conditions.

Resistance factor: A factor that accounts for unavoidable deviations of the actual strength from the nominal end-use value and for the manner and consequences of failure.

Roving: Large number of continuous parallel filaments or a group of untwisted parallel strands.

Row of fasteners: Two or more fasteners aligned with the direction of load.

Second-order analysis: Structural analysis in which equilibrium conditions are formulated on the deformed structure, thereby taking $P-\delta$ and $P-\Delta$ effects into account.

Serviceability limit state: A limiting condition affecting the ability of a structure to preserve its appearance, maintainability, durability and the comfort of its occupants under normal usage.

Service load combination: Load combination under which serviceability limit states are evaluated.

Simple connection. A connection that transmits negligible bending moment.

Single curvature: Deformed shape of a beam, column or beam-column with no inflection point within the span.

Stability limit state: A limit state in which a slight disturbance in the loads or geometry produces large displacements; denoted *instability*.

Stiffener: A structural element that is attached to a member to distribute load, transfer shear and bearing forces or increase in buckling capacity.

Strength limit state: A limiting condition affecting the safety of a structure, component or connection.

Stress concentration: Localized stress amplification produced due to abrupt changes in geometry or loading.

Stress range. Magnitude of change in stress due to the repeated application and removal of service live loads, used in checking susceptibility to fatigue.

Strong axis. The major principal centroidal axis of a cross section.

Structural component: A structural member, connector, or connecting element or assemblage.

Structural system: An assemblage of load-carrying components that are joined together to work as an interdependent unit in resisting loads.

Symmetric composite: a composite in which the sequence of laminae below the laminate mid-plane is a mirror image to those above the laminate mid-plane.

Time-effect factor: A factor applied to the nominal resistance to account for effects of duration of load (refer to load duration); synonymous with duration-of-load factor, or is applied to the modulus of elasticity to account for effects of creep on modulus.

Torsional bracing: Bracing resisting twist of a beam or column.

Torsional buckling: A buckling mode in which the compression member twists about its shear center without lateral movement.

Toughness: Toughness (area under stress-strain curve or moment rotation curve) is the ability to absorb energy and can be quantified by computing the work done per unit mass of material.

Material transverse direction: Direction, in the plane of elements (flange, web, stem, leg,), orthogonal to the material longitudinal direction.

Unbraced length: The distance between points of bracing of a member, measured as the distance between centers of gravity of the bracing members.

Weak axis. The minor principal centroidal axis of a cross section.

SYMBOLS & NOTATIONS

| Symbol | Definition | Section |
|------------|---|------------------------|
| A_g | gross area of member, in. ² (mm ²) | 2.10, 3.3, 4.2, 4.3 |
| A_n | net area of member, in. ² (mm ²) | 2.10, 3.3 |
| A_e | effective net area of member, in. ² (mm ²) or of plates, in. ² /in. (mm ² /mm) | 2.10, 7.5 |
| A_w | Area of webs, in. ² (mm ²) | 5.6 |
| A_b | Nominal unthreaded body area of bolt, in. ² (mm ²) | 8.3 |
| A_{ns} | Net area subjected to shear, in. ² (mm ²) | 8.3 |
| A_{nt} | Net area subjected to tension, in. ² (mm ²) | 8.3 |
| A_1 | Area of FRP concentrically bearing on a concrete support, in. ² (mm ²) | 8.4 |
| A_2 | Maximum area of the portion of the supporting surface that is geometrically similar to and concentric with the loaded area, in. ² (mm ²) | 8.4 |
| b_r | outer width of rectangular tube section, in. (mm) | 6.3.1 |
| C_b | lateral-torsional buckling modification factor for non-uniform moment when both ends of unsupported segment are braced | 2.5, 5.2 |
| C_m | stability coefficient, assuming no translation of compression member ends | 2.5 |
| C_p, C_s | ponding flexibility coefficients for primary and secondary members supporting flat roof | 2.7 |
| C_b | Moment modification factor | 5.2 |
| C_ω | Warping constant, in. ⁶ (mm ⁶) | 5.2 |
| C | torsion constant, in. ³ (mm ³) | 2.8, 6.3 |
| C_Δ | Geometry factor | 8.3 |
| C_L | Coefficient for bearing load in the longitudinal direction of pultruded material | 8.3 |
| $C_{op,L}$ | Coefficient for bypass load in the longitudinal direction of pultruded material | 8.3 |
| $C_{op,T}$ | Coefficient for bypass load in the transverse direction of pultruded material | 8.3 |
| C_{CA} | Composite action factor for assembly stiffness | 2.4 |
| C_{CH} | Chemical environment factor | 2.4 |
| C_{LS} | Load sharing factor for moment resistance | 2.4 |
| C_M | Moisture condition factor for sustained in-service moisture | 2.4 |
| C_T | Temperature factor for sustained elevated in-service temperatures | 2.4 |
| C_T | Coefficient for bearing load in the transverse direction of pultruded material | 8.3 |
| D | Dead load | 1.5, 2.3 |
| D | diameter (in) | 4.4 |
| D_J | torsional rigidity of the section | 4.4, 5.2 |
| D_w | warping rigidity of the section | 4.4 |

| | | |
|-----------|--|------------------------------|
| D_n | Nominal diaphragm strength per unit length, kip/in. (kN/mm) | 7.8 |
| D_u | Required diaphragm strength per unit length, kip/in. (kN/mm) | 7.8 |
| E | Earthquake load | 1.5, 2.3 |
| E_L | Adjusted mean values of longitudinal elastic modulus (taken as minimum in tension and in compression) used for structural analysis only. Characteristic longitudinal elastic modulus when used for capacity calculation (taken as minimum in tension and in compression), ksi (MPa) | 1.4, 2.5, 2.7, 4.3, 5.2, 5.3 |
| EI | flexural rigidity (in. ² -kips) | 5.3 |
| $E_{L,f}$ | Characteristic longitudinal elastic modulus of the flange (taken as minimum in tension and in compression), ksi (MPa) | 4.4 |
| $E_{T,w}$ | Characteristic transverse elastic modulus of the web (taken as minimum in tension and in compression), ksi (MPa) | 4.4 |
| $E_{L,a}$ | Characteristic longitudinal modulus of the element(s) perpendicular to the buckled element (taken as minimum in tension and in compression), ksi (MPa) | 5.2 |
| $E_{L,e}$ | Characteristic longitudinal elastic modulus of the buckled element (taken as minimum in tension and in compression), ksi (MPa) | 5.2 |
| $E_{L,w}$ | Characteristic longitudinal elastic modulus of the web(s) (taken as minimum in tension and in compression), ksi (MPa) | 4.4, 5.2, 5.3 |
| $E_{T,a}$ | Characteristic transverse elastic modulus of the element(s) perpendicular to the buckled element (taken as minimum in tension and in compression), ksi (MPa) | 5.2 |
| $E_{T,f}$ | Characteristic transverse elastic modulus of the flange(s) (taken as minimum in tension and in compression), ksi (MPa) | 5.2 |
| $E_{T,e}$ | Characteristic transverse elastic modulus of the buckled element (taken as minimum in tension and in compression), ksi (MPa) | 5.2 |
| $E_{T,w}$ | Characteristic transverse elastic modulus of the web(s), ksi (MPa) | 4.4, 5.3 |
| $(E_L)_s$ | Characteristic longitudinal elastic modulus of web stiffener (taken as minimum in tension and in compression), ksi (MPa) | 5.3 |
| $(EI)_s$ | Flexural rigidity of a web stiffener, kip-in. ² (N-mm ²) | 5.3 |
| E_b | Characteristic full-section flexural modulus, ksi (MPa) | 5.5 |
| E_L | Characteristic longitudinal elastic modulus, ksi (MPa) | 1.4, 2.3, 7.2, 7.3, 7.6, 7.7 |
| E_T | Characteristic transverse elastic modulus, ksi (MPa) | 7.2, 7.3, 7.6, 7.7 |
| F | Fluid load for fluids with well-defined pressures and maximum heights | 1.5 |

| | | |
|---------------|---|-------------------------------|
| F_{cr} | elastic Euler buckling stress, ksi (MPa) | 4.2, 4.4, 5.2, 5.3, 6.3 |
| F_n | nominal tensile strength from coupon tests, ksi (MPa) | 3.3, 6.3 |
| F_L^c | Minimum characteristic longitudinal compressive material strength of all elements comprising the cross section, ksi (MPa) | 4.2, 7.6 |
| F_T^c | Characteristic transverse compressive strength | 7.6 |
| F_{crx} | Elastic flexural buckling stress about the x -axis, ksi (MPa) | 4.4 |
| F_{cry} | Elastic flexural buckling stress about the y-axis, ksi (MPa) | 4.4 |
| F_{crf} | Local flange buckling stress, ksi (MPa) | 4.4 |
| F_{crw} | Local web buckling stress, ksi (MPa) | 4.4 |
| F_{crz} | Elastic torsional-buckling stress, ksi (MPa) | 4.4 |
| $F_{L,f}^t$ | Characteristic longitudinal tensile strength of the flange(s), ksi (MPa) | 5.2 |
| $F_{L,w}^t$ | Characteristic longitudinal tensile strength of the web(s), ksi (MPa) | 5.2 |
| $F_{L,f}^c$ | Characteristic longitudinal compressive strength of the flange(s), ksi (MPa) | 5.2 |
| $F_{L,w}^c$ | Characteristic longitudinal compressive strength of the web(s), ksi (MPa) | 5.2 |
| $F_{T,f}^t$ | Characteristic transverse tensile strength of the flange(s), ksi (MPa) | 5.4, 7.4 |
| $F_{T,w}^t$ | Characteristic transverse tensile strength of the web(s), ksi (MPa) | 5.4 |
| $F_{T,f}^c$ | Characteristic transverse compressive strength of the flange(s), ksi (MPa) | 5.4 |
| $F_{T,w}^c$ | Characteristic transverse compressive strength of the web(s), ksi (MPa) | 5.4 |
| F_L^c | Characteristic longitudinal compressive strength, ksi (MPa) | 4.2, 7.6 |
| F_L^{cr} | Longitudinal buckling stress, ksi (MPa) | 7.6 |
| F_{LT}^{cr} | In-plane shear buckling stress, ksi (MPa) | 7.7 |
| F_L^t | Characteristic longitudinal tensile strength, ksi (MPa) | 7.5, 7.6, 8.3 |
| F_{LT}^v | Characteristic in-plane shear strength, ksi (MPa) | 4.3 |
| F_n | Characteristic strength, ksi/inch (MPa/mm) | 6.3 |
| F_n | Nominal tensile strength F_{nt} , or nominal shear strength F_{nv} , of steel bolt | 8.3 |
| F_L^f | Characteristic longitudinal flexural strength, ksi (MPa) | 7.2, 7.3 |
| F_T^f | Characteristic transverse flexural strength, ksi (MPa) | 7.2, 7.3 |
| F_T^c | Characteristic transverse compressive strength, ksi (MPa) | 7.6 |
| F_T^t | Characteristic transverse tensile strength, ksi (MPa) | 7.5, 8.3 |

| | | |
|-------------------|--|-----------------------|
| F_L^{tg} | Characteristic open-hole gross-section longitudinal tensile strength, ksi (MPa) | C7.5 |
| F_T^{tg} | Characteristic open-hole gross-section transverse tensile strength, ksi (MPa) | C7.5 |
| F_L^{tn} | Characteristic open-hole net-section longitudinal tensile strength, ksi (MPa) | 7.5 |
| F_T^{tn} | Characteristic open-hole net-section transverse tensile strength, ksi (MPa) | 7.5 |
| F_L^v | Characteristic through-the-thickness shear strength on a plane perpendicular to the material longitudinal direction, ksi (MPa) | 7.4 |
| F_T^v | Characteristic through-the-thickness shear strength on a plane perpendicular to the material transverse direction, ksi (MPa) | 7.4 |
| F_{LT} | Characteristic in-plane shear strength, ksi (MPa) | 7.7 |
| F^t | Characteristic pull-through strength per fastener | 7.4 |
| F_{nt}^t | Characteristic tensile stress modified to include effects of shear stress, ksi (MPa) | 8.3 |
| F_{θ}^{br} | Characteristic pin-bearing strength for the orientation of the resultant force at the bolt/FRP contact with respect to the direction of pultrusion, ksi (MPa) | 8.3 |
| F_L^{br} | Characteristic pin-bearing strength in the longitudinal direction of FRP, ksi (MPa) | 8.3 |
| F_T^{br} | Characteristic pin-bearing strength in the transverse direction of FRP, ksi (MPa) | 8.3 |
| F_L^{tn} | Characteristic open-hole net-section longitudinal tensile strength | 7.5 |
| F_T^{tn} | Characteristic open-hole net-section transverse tensile strength | 7.5 |
| F_{nt} | Nominal tensile strength of bolt, ksi (MPa) | 8.3 |
| F_{nv} | Nominal shear strength of bolt, ksi (MPa) | 8.3 |
| F_{LT}^{sh} | Characteristic in-plane shear strength, ksi (MPa) | |
| F_{sh} | Characteristic in-plane shear strength, ksi (MPa) | 8.3 |
| F_{int}^{sh} | Characteristic interlaminar (short beam shear) shear strength, ksi (MPa) | 5.4 |
| $F_{sh,int}$ | Characteristic shear strength in the through-the-thickness plane of the FRP material, taken to be the characteristic in-plane shear strength, ksi (MPa) | 8.3 |
| $F_{sh,tt}$ | Characteristic shear strength in the through-thickness plane of the FRP material, ksi (MPa) | 8.3.2.2 |
| G_b | Characteristic full-section shear modulus, ksi (MPa) | 5.4 |
| G_{LT} | Adjusted mean values of in-plane shear modulus (used for structural analysis only). Characteristic in-plane shear modulus when used for capacity calculation, ksi (MPa) | 1.4, 2.3, 4.4, 7.6 |
| H | Load due to lateral earth pressure, ground water pressure, | 1.5, 4.4 |

| | | |
|----------------------------|---|------------------------------|
| | or pressure of bulk materials | |
| I | moment of inertia about axis of bending (in. ⁴) | 5.2 |
| I_f | Moment of inertia of the flange(s) about the neutral axis of the section, in. ⁴ (mm ⁴) | 5.2 |
| I_w | Moment of inertia of the web(s) about the neutral axis of the section, in. ⁴ (mm ⁴) | 5.2 |
| J | torsional constant computed as per 6.3-3 and 6.3-4, in. ⁴ (mm ⁴) | 6.3 |
| K | effective length factor determined in. accordance with Section 2.5.3 | 2.5, 4.3, 4.4 |
| K_e | effective stress concentration factor for a plate of finite width with a circular open-hole | 3.3 |
| K_{br} | Required bracing stiffness | 2.5 |
| K_x | Effective length factor corresponding to the x-axis | 4.4 |
| K_y | Effective length factor corresponding to the y-axis | 4.4 |
| $K_{nt,L}$ | Net tension stress concentration factor in longitudinal material direction for a filled hole | 8.3 |
| $K_{nt,T}$ | Net tension stress concentration factor in transverse material direction for a filled hole | 8.3 |
| $K_{op,L}$ | Net tension stress concentration factor in longitudinal material direction for an unfilled hole | 8.3 |
| $K_{op,T}$ | Net tension stress concentration factor in transverse material direction for an unfilled hole | 8.3 |
| L | Live load produced by the use and occupancy of the building, including impact, but not including environmental loads such as snow, wind or rain | 1.5, 2.3, 2.5, 3.4, 3.5, 6.3 |
| L | length of member (in) | 2.5 |
| L_r | Live load on the roof produced during maintenance by workers, equipment, and materials, or during ordinary use by movable objects and people. | 1.5, 2.3 |
| L | laterally unbraced length of a member, in. (mm) | 4.4 |
| L_e | Effective length of a member | 4.2, 4.3 |
| L_b | Length points that are either braced against lateral displacement of compression flange or braced against twist of the cross section, in.(mm) | 2.5, 5.2 |
| L_{br} | Proportion of load at first row of bolts | 8.3 |
| M_{br} | Required brace moment (in-kip) | 2.5 |
| M_{lt} | First-order moment in frame caused by lateral translation (in-kip) | 2.5 |
| M_{nt} | first-order moment in frame with no lateral translation (in-kip) | 2.5 |
| M_{max} | Absolute value of maximum moment in the unbraced segment, kip-in. (N-mm) | 5.2 |
| M_n | Nominal flexural strength of member, kip-in. (N-mm), or of plate, kip-in./ in. (kN-mm/mm) | 5.2, 7.3, 7.8 |
| $M_c = \lambda \phi_b M_n$ | Available flexural strength determined, kip-in. (kN-mm) | 6.2, 6.3 |
| M_u | Required flexural strength due to factored loads of member, kip-in. (kN-mm), or of plate, kip-in./ in. (kN- | 2.5, 5.2, 6.3, 7.3, |

| | | |
|-------------------------|---|------------------------------|
| | mm/mm) | 7.8 |
| N_n^c | Nominal compressive strength per unit length, kip/in. (kN/mm) | 7.6 |
| N_u^c | Required compressive strength per unit length, kip/in. (kN/mm) | 7.6 |
| $N_{L,n}^c$ | Nominal longitudinal compressive strength per unit length, kip/in (kN/mm) | 7.6 |
| $N_{T,n}^c$ | Nominal transverse compressive strength per unit length, kip/in (kN/mm) | 7.6. |
| $N_{LT,n}$ | Nominal strength for in-plane shear loading per unit length, kip/in. (kN/mm) | 7.7 |
| $N_{LT,u}$ | Required strength for in-plane shear loading per unit length, kip/in. (kN/mm) | 7.7 |
| N_n^t | Nominal tensile strength per unit length, kip/in. (kN/mm) | 7.5.1, 7.5.2, 7.5.3 |
| N_u^t | Required tensile strength per unit length, kip/in. (kN/mm) | 7.5.1, 7.5.2, 7.5.3 |
| P_{br} | Required brace strength (kips) | 2.5 |
| P_e | Euler buckling strength (kips) | 2.5 |
| P_n | adjusted nominal axial strength (kips) | 3.2, 3.3, 4.2 |
| P_u | required axial strength due to factored loads (kips) | 2.5, 3.2, 4.2 |
| P_S | Compression force due to serviceability load combinations | 4.2 |
| P_D | Compression force due to dead load | 4.3 |
| $P_c = \lambda\phi P_n$ | available axial tensile or compressive strength determined in accordance with Chapters 3 or 4, kip (kN) | 6.2, 6.3 |
| P_p | Bearing strength for column base bearing on concrete, kip (kN) | 8.4 |
| R | Rain load or ice load exclusive of contributions caused by ponding | 1.5, 6.3 |
| R_o | Reference strength | 2.4 |
| R_n | Nominal strength adjusted for end-use conditions | 2.3, 2.4, 5.4 |
| R_n | Nominal connection strength determined in accordance with Sections 8.3.2 and 8.3.3 | 8.3 |
| R_u | Required strength due to factored loads | 1.4, 2.3, 5.4,7.2, 8.3 |
| R_i | inner radius of a circular tube, in. (mm) | 6.3 |
| R_n^t | Nominal pull-through strength per fastener, kip (kN) | 7.4 |
| R_u^t | Required pull-through strength per fastener, kip (kN) | 7.4 |
| R_{br} | Pin-bearing strength, kip (kN) | 8.3 |
| R_{bs} | Block shear strength when the load is concentric, kip (kN) | 8.3 |
| $R_{bs,e}$ | Block shear strength when the load is eccentric, kip (kN) | 8.3 |

| | | |
|---------------------------|---|--------------------|
| R_{bt} | Bolt strength, kip (kN) | 8.3 |
| R_{cl} | Cleavage strength, kip (kN) | 8.3 |
| R_{nt} | Net tension strength for a single bolted connection, kip (kN) | 8.3 |
| $R_{nt,f}$ | Net tension strength at first bolt row for a connection with two or three rows of bolts, kip (kN) | 8.3 |
| R_{sh} | Shear-out strength, kip (kN) | 8.3 |
| $R_{sh,sp}$ | Shear strength of shear plate material, kip (kN) | 8.3 |
| R_{tt} | Tension (through-the-thickness) strength, kip (kN) | 8.3 |
| S | Snow load caused by uniform deposition, drifting, and/or other unbalanced conditions | 1.5, 2.3 |
| S_{pr} | Geometric ratio w/d or g/d | 8.3 |
| T | Self-straining force, including temperature or differential settlement | 1.5 |
| T_g | glass transition temperature of the composite system determined in accordance with ASTM D4065 | 1.1, 2.4 |
| $T_c = \lambda\phi_T T_n$ | available torsional design strength in accordance with 6.3.1, kip-in. (kN-mm) | 6.3 |
| T_n | nominal torsional design strength, kip-in. (kN-mm) | 6.3 |
| T_u | required torsional strength due to factored loads, kip-in. (kN-mm) | 6.3 |
| U | shear lag factor | 2.10 |
| V_R | coefficient of variation of test results; | 2.3 |
| V_n | Nominal shear strength of members, kip (kN), and of plates, kip-in./ in. (kN-mm/mm) | 5.3, 7.4 |
| V_u | Required shear strength of members, kip (kN), and of plates, kip-in./ in. (kN-mm/mm) | 5.3, 7.4 |
| W | Wind load | 1.5, 2.3 |
| a | Span length of the plate in the material longitudinal direction | 7.2, 7.3, 7.6 |
| b_a | Length of the adjacent (and perpendicular) element(s) at the end(s) of the buckled element (full flange width for flanges, full section depth for webs), in. (mm) | 5.2 |
| b_e | Length of the buckled element (full flange width for flanges, full section depth for webs), in. (mm) | 5.2 |
| b_f | Flange width, in. (mm) | 4.4, 5.2, 6.3 |
| b_p | Length of bearing plate, in. (mm) | 5.4 |
| b_s | Spacing of stiffeners along the length of the beam, in. (mm) | 2.5, 5.3 |
| b | Span length of the plate in the material transverse direction, in. (mm) | 7.2, 7.3, 7.6, 7.7 |
| b_s | Staggered bolt dimension, in. (mm) | 2.5, 5.3, 8.3 |
| c | Shape constant for rotational restraint | 5.2 |
| d_w | the clear depth of the web, in. (mm) | 5.3, 6.3, 8.3 |
| d | Nominal bolt diameter, in. (mm) | 4.4 |
| d_n | Nominal hole diameter, in. (mm) | C7.5, 8.3 |

| | | |
|--------------|--|--|
| d_w | Nominal diameter of washer, in. (mm) | 5.3, 8.3 |
| e_1 | End distance, in. (mm) | 8.1, 8.3 |
| e_2 | Edge distance, in. (mm) | 8.2, 8.3 |
| E_3, e_4 | Width distance, in. (mm) | 8.3 |
| f'_c | Specified minimum compressive strength of the concrete, ksi (MPa) | 8.4 |
| f_{cr} | Critical stress for indicated failure mode, ksi (MPa) | 5.4 |
| f_v | Required shear stress for bolt, ksi (MPa) | 2.10, 8.3 |
| g | Gage spacing when the bolting is not staggered, in. (mm) | 8.2 |
| g_s | Gage spacing when the bolting is staggered, in. (mm) | 8.2 |
| h | Overall section depth, in. (mm) | 5.2, 5.3, 5.4, 6.3 |
| $I_{y,f}$ | Moment of Inertia of the flanges about the weak axis, in. ⁴ (mm ⁴) | 5.2 |
| I_x | moment of inertia about strong axis, in. ⁴ (mm ⁴) | 2.5 |
| I_y | moment of inertia about weak axis, in. ⁴ (mm ⁴) | 2.5 |
| k | Distance from the top of a section to the bottom of the fillet = $t_f + r$, in. (mm) | 5.4 |
| k_{cr} | Edge rotation partial restraint coefficient | 7.6 |
| k_r | Rotational spring constant, kip/rad (kN/rad) | 5.2 |
| k_{LT} | Shear buckling coefficient | 5.3 |
| k_L^{-1} | Open-hole (notched) longitudinal strength reduction factor | 7.5 |
| k_T^{-1} | Open-hole (notched) transverse strength reduction factor | 7.5 |
| l_e | Concentrated load eccentricity from the web, in. (mm) | 5.4 |
| l_{eff} | Effective web compression buckling length, in. (mm) | 5.4 |
| l_{ten} | Length of web subjected to concentrated tensile force, in. (mm) | 5.4 |
| l_s | Stagger distance, in. (mm) | 8.2 |
| l_{sp} | Depth of shear plate at the radius of the leg-angle profile, in. (mm) | 8.3 |
| n | Number of bolts across the effective width | 8.3.2.4, 8.3.3.2 |
| r | Radius of the web-flange junction fillet, in. (mm) | 3.4, 3.5 |
| s | Pitch spacing, in. (mm) | 2.16 |
| t | Thickness of FRP material, in. (mm) | 2.6, 4.4, 5.4, 6.3, 7.2, 7.3, 7.4, 7.6, 7.7, 8.3 |
| $t_{n-1, p}$ | Student t-statistic with n-1 degrees of freedom, evaluated at p = 0.99 for members and p = 0.999 for connections | 2.3 |
| t_a | Thickness of the element(s) adjacent (and perpendicular) to the buckled element at its end(s), in. (mm) | 5.2 |
| t_e | Thickness of the buckled element, in. (mm) | 5.2 |
| t_f | Flange thickness, in. (mm) | 4.4, 5.2, 5.4, 6.3 |

| | | |
|-----------------------|--|--|
| t_w | Web thickness, in. (mm) | 2.5, 4.4, 5.2, 5.3, 5.4, 6.3 |
| t_{sp} | Minimum material thickness in leg of angle, in. (mm) | 8.3.4.1.1 |
| w | Effective width, width of a plate at the plane of failure, in. (mm) | C7.5 |
| x | subscript referring to strong axis bending | 6.2 |
| $y_{c,f}$ | Distance from the neutral axis of the section to the extreme fiber in compression in a flange element, in. (mm) | 5.2 |
| $y_{c,w}$ | Distance from the neutral axis of the section to the extreme fiber in compression in a web element, in. (mm) | 5.2 |
| $y_{t,f}$ | Distance from the neutral axis of the section to the extreme fiber in tension in a flange element, in. (mm) | 5.2 |
| $y_{t,w}$ | Distance from the neutral axis of the section to the extreme fiber in tension in a web element, in. (mm) | 5.2 |
| $y_{c,e}$ | Distance from the neutral axis of the section to the extreme fiber in compression in the buckled element of the section (e.g., the flange or web), in. (mm) | 5.2 |
| y | subscript referring to weak axis bending | 6.2 |
| Δ | first-order interstory drift in frame due to lateral force, in. (mm) | 2.6 |
| Δ, Δ_{st} | Total deflection, instantaneous deflection used to calculate long-term deflection under sustained gravity load, in. (mm) | 2.6 |
| β | highest value of width (center to center) to thickness ratio of wall element under consideration in a rectangular (hollow) cross section | 4.4 |
| γ | coupon specimen shear strain per unit length as defined in ASTM D5379-05, 1/in. (1/mm) | 6.3 |
| η_{LT} | Elastic parameter for in-plane shear buckling stress | 7.7 |
| θ | Angle of loading, the angle between the direction of the connection force and the direction of pultrusion, degrees | 8.3 |
| λ | time effect factor | 2.2, 3.2, 4.2, 5.2, 5.3, 5.4, 6.2, 6.3, 7.3, 7.4, 7.5, 7.6, 7.7, 7.8, 8.3 |
| ν_{LT} | Characteristic value of Poisson's ratio associated with transverse strain when strained in the longitudinal direction. In absence of specific test data, a value of 0.3 may be used. | 4.4 |
| ξ | Coefficient of restraint | 5.2 |
| ξ_{LT} | Ratio of applied transverse to longitudinal compressive loading | 7.6 |
| ϕ | resistance factor | 2.3, 3.2, |

| | | |
|---|---|--|
| | | 4.2, 5.2, 5.3, 5.4, 6.2, 6.3, 8.3 |
| ϕ | Resistance factor | 7.2 |
| ϕ_c | Resistance factor for compression | 4.3, 4.4, 6.2, 7.6 |
| ϕ_f | Resistance factor for flexure | 7.3, 7.8 |
| ϕ_v | Resistance factor for shear | 7.4, 7.7 |
| ϕ_t | Resistance factor for tension | 7.5, 7.8 |
| ϕ_b | Resistance factor for steel bolts | 8.3 |
| ϕ_c | Resistance factor for connection | 8.3 |
| ϕ_{cc} | Resistance for concrete crushing | 8.4 |
| Φ | Geometry term in net tension strength formulae | 8.3 |
| <i>Superscripts c, t, f, v, cr</i> | Compression, tension, flexure (also used as subscript), transverse shear (also used as subscript), buckling (also used as subscript), respectively. | |
| <i>Subscripts L, T, w, f, b, br</i> | Longitudinal, transverse, in-plane shear, web, flange, bolt, bearing, respectively. | |

1. GENERAL PROVISIONS

This chapter establishes the scope of the Standard and its design basis, summarizes referenced specifications and standards, and provides general requirements for materials, contract documents, fabrication and quality assurance. The chapter is organized as follows:

- 1.1 Scope
- 1.2 Referenced specifications, codes and standards
- 1.3 Materials
- 1.4 Design basis
- 1.5 Loads and load combinations
- 1.6 Structural design drawings and specifications
- 1.7 Fabrication, construction and quality assurance

1.1 Scope

1.1.1 Applicability and Exclusions

This standard is intended to be used for the design of new buildings and other structures constructed of pultruded glass fiber-reinforced polymer (FRP) composite structural shapes, connections and pre-fabricated building products. Tendons and cables are not covered by this standard. The standard is applicable to pultruded FRP structural shapes that have symmetric and balanced glass reinforcement and fiber architecture combined with a polymeric matrix.

1.1.2 Maximum Service Temperature

The maximum service temperature for pultruded FRP structural members, components and systems designed by this standard shall not exceed $T_g - 40^\circ\text{F}$ ($T_g - 22^\circ\text{C}$), in which T_g is the glass transition temperature of the composite system determined in accordance with ASTM D4065.

1.1.3 Units

Where units are required in the provisions of this standard, they are provided in U.S. customary units, with SI units provided either parenthetically or as footnotes to tables. Many of the equations presented do not require explicit statement of units; in these equations the designer shall use units for all quantities that are consistent.

1.2 Referenced Specifications, Codes and Standards

The following specifications, standard and codes are referenced in this *Standard*.

| | |
|-----------|---|
| ASCE 7-10 | <i>Minimum design loads for buildings and other structures (ASCE Standard 7-10)</i> |
| ASTM A193 | Standard Specification for Alloy-Steel and Stainless Steel Bolting Materials for High Temperature or High Pressure Service and Other Special Purpose Applications |
| ASTM A307 | Standard Specification for Carbon Steel Bolts and Studs, 60 000 psi Tensile Strength |
| ASTM A325 | Standard Specification for Structural Bolts, Steel, Heat Treated, 120/105 ksi Minimum Tensile Strength |

| | |
|------------|---|
| ASTM A563 | Standard Specification for Carbon and Alloy Steel Nuts |
| ASTM C581 | Standard Practice for Determining Chemical Resistance of Thermosetting Resins Used in Glass-Fiber-Reinforced Structures Intended for Liquid Service |
| ASTM C666 | Standard Test Method for Resistance of Concrete to Rapid Freezing and Thawing |
| ASTM D570 | Standard Test Method for Water Absorption of Plastics |
| ASTM D578 | Standard Specification for Glass Fiber Strands |
| ASTM D638 | Standard Test Method for Tensile Properties of Plastics |
| ASTM D696 | Standard Test Method for Coefficient of Linear Thermal Expansion of Plastics Between -30°C and 30°C with a Vitreous Silica Dilatometer |
| ASTM D790 | Standard Test Methods for Flexural Properties of Unreinforced and Reinforced Plastics and Electrical Insulating Materials |
| ASTM D883 | Standard Terminology Relating to Plastics |
| ASTM D907 | Standard Terminology of Adhesives |
| ASTM D953 | Standard Test Method for Bearing Strength of Plastics |
| ASTM D1144 | Standard Practice for Determining Strength Development of Adhesive Bonds |
| ASTM D2343 | Standard Test Method for Tensile Properties of Glass Fiber Strands, Yarns, and Rovings Used in Reinforced Plastics |
| ASTM D2344 | Standard Test Method for Short-Beam Strength of Polymer Matrix Composite Materials and Their Laminates |
| ASTM D2583 | Standard Test Method for Indentation Hardness of Rigid Plastics by Means of a Barcol Impressor |
| ASTM D3878 | Standard Terminology of High-modulus Reinforcing Fibers and their Composites |
| ASTM D3917 | Standard Specification for Dimensional Tolerance of Thermosetting Glass-reinforced Plastic Pultruded Shapes |
| ASTM D4065 | Standard Practice for Plastics: Dynamic Mechanical Properties: Determination and Report of Procedures |
| ASTM D4385 | Standard Practice for Classifying Visual Defects in Thermosetting Reinforced Plastic Pultruded Products |
| ASTM D4762 | Standard Guide for Testing Polymer Matrix Composite Materials |
| ASTM D5379 | Standard Test Method for Shear Properties of Composite Materials by the V-Notched Beam Method |
| ASTM D5766 | Standard Test Method for Open-Hole Tensile Strength of Polymer Matrix Composite Laminates |
| ASTM D6641 | Standard Test Method for Determining the Compressive Properties of Polymer Matrix Composite Laminates Using a Combined Loading Compression (CLC) Test Fixture |
| ASTM D7136 | Standard Test Method for Measuring the Damage Resistance of a Fiber-reinforced Polymer Matrix Composite to a Drop-weight Impact Event |
| ASTM D7290 | Standard Practice for Evaluating Material Property Characteristic Values for Polymeric Composites for Civil Engineering Applications |
| ASTM D7332 | Standard Test Method for Measuring the Fastener Pull-through Resistance of a Fiber-reinforced Polymer Matrix Composite |
| ASTM F593 | Standard Specification for Stainless Steel Bolts, Hex Cap Screws and Studs |
| ASTM F594 | Standard Specification for Stainless Steel Nuts |
| ASTM G154 | Standard Practice for Operating Fluorescent Light Apparatus for UV Exposure of Nonmetallic Materials |

Code of Standard Practice for Fabrication and Installation of Pultruded FRP Structures (ACMA document, under development at the time of preparation of the Pre-Standard)

In the event of conflict between the reference specifications, codes and standards and this *Standard*, the design of FRP pultruded structural systems shall be governed by this *Standard*.

1.3 Materials

This section provides general requirements for FRP composite material systems intended for the manufacture of pultruded FRP components and systems used in the structural design of buildings and other structures.

1.3.1 FRP Constituent Materials

Pultruded materials shall conform to the requirements of this section.

(a) Fiber System

Fiber Type: It is permitted to use any commercial grade glass fiber in the polymer system. Glass fibers shall conform to ASTM D578.

Fiber Form: It is permitted to use any form of fiber, such as rovings, woven fabrics, braided fabrics, stitched fabrics, continuous fiber mats, continuous strand mats, continuous filament mats (CFM), and chopped strand mats (CSM) of any size or weight.

Fiber Orientations: Each element of a pultruded FRP structural member shall have reinforcing fibers oriented in a minimum of two directions separated by a minimum of 30 degrees. This requirement shall not apply to rods and bars with uni-directional reinforcement that are pre-qualified in accordance with Section 2.3.2.

Fiber Architecture: The fiber architecture of any pultruded element comprising the cross section of a pultruded FRP structural member shall be symmetric and balanced.

Fiber Volume Fraction: The minimum total fiber volume fraction of each pultruded FRP structural element shall not be less than 30%.

Percentage of Fiber Orientation: The percentage of continuous fiber in each pultruded FRP structural element in the direction of the longitudinal axis of the member shall not be less than 30% of the total fiber reinforcement by volume for shapes and not less than 25% of the total fiber reinforcement by volume for plates. When multiple elements share a common edge in the direction of pultrusion, at least 50% of the non-roving reinforcement in the element having the largest percentage of non-roving reinforcement and sharing the common edge shall extend through the junction connecting the elements.

Minimum Tensile Strength: The characteristic value, determined according to ASTM D7290, of the tensile strength of the glass fiber strands, yarns and rovings shall not be less than 290 ksi (2,000 MPa), as determined by a tension test conducted according to ASTM D2343.

(b) Matrix

1. Resin

The resin system used for fabricating pultruded FRP structural members and components for buildings and other structures shall be a commercial grade thermoset resin.

2. Other Constituent Materials

Additives to the resin system that influence processing or curing, such as fillers, promoters, accelerators, inhibitors, UV agents, and pigments, shall be compatible with the fiber and resin system. Where

stipulated by the Engineer of Record, each additive shall be identified by its generic name and weight fraction with respect to the resin system.

1.3.2 Physical and Mechanical Properties of Pultruded FRP Products

The physical properties of pultruded FRP products shall conform to the requirements of Table 1.3-1.

Table 1.3-1 Required Physical Properties for FRP Materials

| Physical Property | Requirement | ASTM Test Method | Min. No. of Tests | COV |
|----------------------------------|--|------------------|-------------------|---------------|
| Barcol Hardness | Greater than 40 | D2583 | 5 | Less than 10% |
| Glass Transition Temperature | Greater than 180°F (82°C) | D4065 | 5 | Less than 10% |
| Coefficient of Thermal Expansion | Less than 7.5×10^{-6} in/in/°F (longitudinal) | D696 | 5 | Less than 10% |
| Moisture Equilibrium Content | Less than 2% | D570, §7.4 | 5 | Less than 10% |

The characteristic mechanical properties of pultruded FRP composite structural members, determined in accordance with ASTM D7290, shall equal or exceed the minimum requirements of Tables 1.3-2(a) for shapes and 1.3-2(b) for plates. These requirements shall apply to each element of the cross section.

Table 1.3-2(a) Minimum Required Characteristic Mechanical Properties for FRP Composite Shapes

| Mechanical Property | Minimum Requirement | ASTM Test Method | Minimum Number of Tests |
|--|------------------------------|-------------------|-------------------------|
| Longitudinal Tensile Strength | 30,000 psi | D638 | 10 |
| Transverse Tensile Strength | 7,000 psi | D638 | 10 |
| Longitudinal Tensile Modulus | 3×10^6 psi | D638 | 10 |
| Transverse Tensile Modulus | 0.8×10^6 psi | D638 | 10 |
| | | | |
| Longitudinal Compressive Strength | 30,000 psi | D6641 | 10 |
| Longitudinal Compressive Modulus | 3×10^6 psi | D6641 | 10 |
| Transverse Compressive Modulus | 1×10^6 psi | D6641 | 10 |
| | | | |
| In-Plane Shear Strength | 8,000 psi | D5379 | 10 |
| In-Plane Shear Modulus | 0.4×10^6 psi | D5379 | 10 |
| Interlaminar shear strength | 3,500 psi | D2344 | 10 |
| | | | |
| Longitudinal pin-bearing strength | 21,000 psi | D953 ^a | 10 |
| Transverse pin-bearing strength | 18,000 psi | D953 ^a | 10 |
| Pull-through strength per fastener t = 3/8 in t = 1/2 in t = 3/4 in | 650 lb 900 lb 1,250 lb | D7332/Proc. B | 10 |

Note: 1 psi = 6.895 kPa; 1 lb = 4.448 N

^aTests shall be conducted with bolt sizes and plate thicknesses stipulated in this *Standard*. The limitation of 4% on deformation shall not apply.

**Table 1.3-2(b) Minimum Required Characteristic Mechanical Properties
for FRP Composite Plates**

| Mechanical Property | Minimum Requirement | ASTM Test Method | Minimum Number of Tests |
|--|------------------------------|-------------------------|--------------------------------|
| Longitudinal Tensile Strength | 20,000 psi | D638 | 10 |
| Transverse Tensile Strength | 7,000 psi | D638 | 10 |
| Longitudinal Tensile Modulus | 1.8 x 10 ⁶ psi | D638 | 10 |
| Transverse Tensile Modulus | 0.7 x 10 ⁶ psi | D638 | 10 |
| | | | |
| Longitudinal Compressive Strength | 24,000 psi | D6641 | 10 |
| Transverse Compressive Strength | 15,500 psi | D6641 | 10 |
| Longitudinal Compressive Modulus | 1.8 x 10 ⁶ psi | D6641 | 10 |
| Transverse Compressive Modulus | 1.0 x 10 ⁶ psi | D6641 | 10 |
| | | | |
| Longitudinal Flexural Strength | 30,000 psi | D790 | 10 |
| Transverse Flexural Strength | 13,000 psi | D790 | 10 |
| Longitudinal Flexural Modulus | 1.6 x 10 ⁶ psi | D790 | 10 |
| Transverse Flexural Modulus | 0.9 x 10 ⁶ psi | D790 | 10 |
| | | | |
| In-Plane Shear Strength | 6,000 psi | D5379 | 10 |
| In-Plane Shear Modulus | 0.4x 10 ⁶ psi | D5379 | 10 |
| Interlaminar shear strength | 3,500 psi | D2344 | 10 |
| | | | |
| Longitudinal pin-bearing strength | 21,000 psi | D953 ^a | 10 |
| Transverse pin-bearing strength | 13,000 psi | D953 ^a | 10 |
| Pull-through strength per fastener t = 3/8 in t = 1/2 in t = 3/4 in | 650 lb 900 lb 1,250 lb | D7332/Proc. B | 10 |

Note: 1 psi = 6.895 kPa

^aTests shall be conducted with bolt sizes and plate thicknesses stipulated in this *Standard*. The limitation of 4% on deformation shall not apply.

1.3.3 Fire, Smoke and Toxicity

Structural components and systems shall be designed in conformance with the applicable building code to protect occupants against injury or death resulting from structural - or collapse or from the spread of fire, smoke or toxic products of combustion.

1.3.4 Durability and Environmental Effects

Materials shall be selected in design so that structural components and systems can tolerate long-term environmental effects during the service life of the structure if they are not protected against such effects.

The following factors shall be considered:

- (a) Performance criteria for the structure;
- (b) Intended service life of the structure;
- (c) Expected environmental conditions, including the likelihood of exposure to alkalis or organic solvents;
- (d) Protective measures; and
- (e) Feasibility of maintenance during service.

Unless the glass transition temperature determined in accordance with ASTM D4065 and the tensile strength of the composite in the longitudinal and transverse directions determined in accordance with ASTM D638, can be shown to retain at least 85% of their characteristic values after conditioning in the environments listed below, the nominal strength and stiffness shall be reduced in accordance with Section 2.4.4(a). Materials that cannot retain at least 15% of their characteristic values after conditioning in the environments listed below shall not be permitted.

Water: Samples shall be immersed in distilled water having a temperature of $100 \pm 3^{\circ}F$ ($38 \pm 2^{\circ}C$) and tested after 1,000 hours of exposure.

Alternating ultraviolet light and condensating humidity: Samples shall be exposed according to Cycle No. 1 ($0.89W/m^2/mm$, 8 hours UV at $60^{\circ}C$, 4 hours condensation at $50^{\circ}C$) using UVA-340 lamps in an apparatus meeting the requirements of ASTM G154. Samples shall be tested within two hours after removal from the apparatus.

Alkali: Where required, the sample shall be immersed in a saturated solution of calcium hydroxide ($pH \geq 11$) at ambient temperature of $73 \pm 3^{\circ}F$ ($23 \pm 2^{\circ}C$) for 1000 hours prior to testing. The pH level shall be monitored and the solution shall be maintained as needed.

Freeze-thaw: Composite panels or coupons shall be exposed to 100 repeated cycles of freezing and thawing in an apparatus meeting the requirements of ASTM C666.

1.3.5 Impact Tolerance

Where impact resistance is stipulated by the Engineer of Record, the stipulated impact resistance shall be determined in accordance with ASTM D7136.

1.4 Design Basis

1.4.1 Limit States Design

This standard is based on limit states design and has adopted the Load and Resistance Factor Design (LRFD) format. Strength limit states are related to structural safety under the maximum loading conditions that occur during the intended service life of the structure. Serviceability limit states relate to structural performance under normal service conditions.

Structural members, connections and systems shall be proportioned so that no applicable limit state is exceeded when the structure is subjected to applicable combinations of loads.

1.4.2 General Analysis Requirements

(a) Required strength. The required strength, R_u , of structural members and connections shall be determined by structural analysis for the appropriate load combinations, as stipulated in Section 1.5.2. It

is permitted to determine load effects on individual components and connections by elastic methods of structural analysis. The analysis shall take into account equilibrium, stability, geometric compatibility, and both short- and long-term material properties. The location of maximum structural action in a non-prismatic member shall be determined by rational analysis for the member geometry and loading under consideration.

(b) Stiffness. Structural analysis shall be based on *mean values* of elastic modulus in the longitudinal direction, E_L , and in-plane shear modulus, G_{LT} , that have been adjusted for end-use conditions in accordance with Section 2.4.4. E_L shall equal the minimum of the values of elastic modulus in tension and in compression in any element of the cross section. G_{LT} shall equal the minimum of the shear modulus in any element of the cross section. E_L and G_{LT} shall not be multiplied by the time effect factor, λ , in determining the required strength.

Shear deformations shall be considered in the analysis of flexural members having a ratio of span to depth less than 20.

(c) End restraints. Simple framing, in which the rotational restraint is ignored, shall be assumed in the structural analysis unless the behavior of the connection for a specified degree of rotational restraint can be demonstrated by experimental or analytical means.

(d) Long-term loading. Structures and members that accumulate residual deformations under service loads or experience loss of strength under sustained load shall have the added deformations or loss of strength expected to occur during their service life included in their analysis when such deformations affect strength or serviceability.

1.4.3 Design for Strength

The design strength of structural systems, members, and connections for each applicable strength or stability limit state determined in accordance with Section 2.3 shall equal or exceed the required strength determined by Section 1.4.2.

Where the composition or configuration of structural components or systems is such that compliance with the provisions of this *Standard* cannot be determined by analysis, it is permitted to establish such compliance on the basis of test results that are evaluated in accordance with Section 2.3.2.

1.4.4 Design for Serviceability

Structural systems, and members and components thereof, shall be designed to limit deflections, lateral drift, vibrations, or any other structural actions that adversely affect the intended use and performance of the building or other structure under conditions of ordinary use.

1.5 Loads and Load Combinations

Nominal loads shall be those required by the applicable building code. In the absence of a governing code, the nominal loads shall be those stipulated in *ASCE Standard 7-10*.

1.5.1. The following nominal loads shall be considered:

- D Dead load caused by the weight of permanent construction, including walls, floors, roofs,

ceilings, fixed partitions, stairways, and fixed service equipment.

| | |
|-------|--|
| D_i | Weight of ice |
| E | Earthquake load. |
| F | Load due to fluids with well-defined pressures and maximum heights. |
| F_a | Flood load |
| H | Load due to lateral earth pressure, ground water pressure, or pressure of bulk materials |
| L | Live load produced by the use and occupancy of the building, including impact, but not including environmental loads such as snow, wind or rain. |
| L_r | Live load on the roof produced during maintenance by workers, equipment, and materials, or during ordinary use by movable objects and people. |
| R | Rain load or ice load exclusive of contributions caused by ponding. |
| S | Snow load caused by uniform deposition, drifting, and/or other unbalanced conditions. |
| T | Self-straining force. |
| W | Wind load. |
| W_i | Wind-on-ice load. |

1.5.2 Load Combinations for Strength Limit States

(a) Basic combinations. Structures, structural members and their connections, and foundations shall be designed so that their design strength equals or exceeds the required strength determined using the following factored load combinations:

$$1.4D \quad (1.5-1)$$

$$1.2D + 1.6L + 0.5(L_r \text{ or } S \text{ or } R) \quad (1.5-2)$$

$$1.2D + 1.6(L_r \text{ or } S \text{ or } R) + 1.0L \text{ or } 0.5W \quad (1.5-3)$$

$$1.2D + 1.0W + 1.0L + 0.5(L_r \text{ or } S \text{ or } R) \quad (1.5-4)$$

$$1.2D + 1.0E + 1.0L + 0.2S \quad (1.5-5)$$

$$0.9D + 1.0W \quad (1.5-6)$$

$$0.9D + 1.0E \quad (1.5-7)$$

Exceptions:

- (1) The load factor on L in combinations 1.5-3, 1.5-4, and 1.5-5 is permitted to equal 0.5 for all occupancies in which L_o in Table 4-1 of *ASCE Standard 7-10* is less than or equal to 100 psf (4.8 kPa), with the exception of garages or areas occupied as places of public assembly.
- (2) In combinations 1.5-2, 1.5-4 and 1.5-5, the companion load S shall be taken as either the flat roof snow load (p_f) or the sloped roof snow load (p_s).

Where fluid loads F are present, they shall be included with the same load factor as dead load D in combinations 1.5-1 through 1.5-5 and 1.5-7.

Where loads H are present, they shall be included as follows:

1. where the effect of H adds to the primary variable load effect, include H with a load factor of 1.6;
2. where the effect of H resists the primary variable load effect, include H with a load factor of 0.9 where the soil load is permanent or a load factor of 0 for all other conditions.

Each relevant strength limit state shall be investigated, including cases where some of the loads in a combination are equal to zero. The most unfavorable effects from both wind and earthquake loads shall be investigated, where appropriate, but they need not be considered to act simultaneously. Unbalanced load conditions shall be investigated in accordance with applicable building code provisions. When the effects of loads counteract one another in a structural member or connection, the design shall account for reversal of axial forces, shears, or moments.

Earthquake load effect, E, shall be determined in accordance with Chapter 12 of *ASCE Standard 7-10*. Unless otherwise permitted or required by the authority having jurisdiction, the response modification factor, R, system over-strength factor, Ω_o , and deflection amplification factor, C_d , shall be determined in accordance with Section 12.2 of *ASCE Standard 7-10*.

(b) Load combinations including flood load. When a structure is located in a flood zone, the following load combinations shall be considered in addition to the load combinations in Section 1.5.2(a):

1. In V-Zones and Coastal A-Zones, 1.0W in combinations 1.5-4 and 1.5-6 shall be replaced by $1.0W + 2.0F_a$
2. In Noncoastal A-Zones, 1.0W in combinations 1.5-4 and 1.5-6 shall be replaced by $0.5W + 1.0F_a$.

(c) Load combinations including atmospheric ice loads. When a structure is subjected to atmospheric ice and wind-on-ice loads, the following load combinations shall be considered:

1. $0.5(L_r \text{ or } S \text{ or } R)$ in combination 1.5-2 shall be replaced by $0.2D_i + 0.5S$.
2. $1.0W + 0.5(L_r \text{ or } S \text{ or } R)$ in combination 1.5-4 shall be replaced by $D_i + W_i + 0.5S$.
3. 1.0W in combination 1.5-6 shall be replaced by $D_i + W_i$.

(d) Load combinations including self-straining loads. Where applicable, the structural effects of T shall be considered in combination with other loads. The load factor on T shall be established considering the

uncertainty associated with the likely magnitude of the force, the probability that the maximum effect of T will occur simultaneously with other applied loadings, and the potential adverse consequences if the effect of T is greater than assumed. The load factor on T shall not have a value less than 1.0.

1.5.3 Load Combinations for Serviceability Limit States

Structures, structural members and their connections, and foundations shall be designed using the following service load combinations so that they remain functional under conditions of ordinary use:

For serviceability limit states involving visually objectionable deformations or drifts, repairable damage to finishes, and similar short-term effects,

$$D + (L \text{ or } 0.5 S) \quad (1.5.8)$$

$$D + 0.5L + 0.4W \quad (1.5.9)$$

For serviceability limit states involving long-term effects, such as creep or differential settlement,

$$D + 0.5L \quad (1.5.10)$$

1.6 Structural Design Drawings and Specifications

The structural design drawings and specifications shall show clearly the work that is to be performed and shall give the following information with sufficient dimensions to convey the quantity and nature of the pultruded FRP composite shapes to be fabricated:

- (a) Size, section, material and location of all members;
- (b) All geometry and working points necessary for layout;
- (c) Floor elevations;
- (d) Column centerlines and offsets;
- (e) Connection locations and fastener details, if required by the contract documents.

The structural design drawings shall show permanent bracing, column stiffeners, bearing stiffeners in beams, web reinforcement, connections and other items at sufficient scale and detail that their quantity, detailing and fabrication requirements can be clearly understood. Any special requirements for camber that are necessary to bring a loaded member into proper relation with the work of other trades shall be set forth in the design documents.

1.7 Fabrication, Construction and Quality Assurance

1.7.1 Shop and Construction Drawings

Shop drawings shall be prepared in advance of fabrication and shall give complete information necessary for the fabrication of structural components and systems, including location, type and size of fasteners, cuts and copes, tolerances, and surface preparation requirements, if applicable. Construction drawings shall be made in advance of erection, and shall give information necessary for erection of the structure. Drawings shall be made with due regard to facilitating fabrication and construction schedules.

1.7.2 Fabrication and Construction

Manufactured components shall be inspected according to ASTM D3917 for dimensional tolerances and according to ASTM D4385 for visual defects.

Fabrication tolerances for members and connections shall conform to the *Code of Standard Practice for Fabrication and Installation of Pultruded FRP Structures*.

Compression members shall be considered to be straight if the variation in straightness is equal to or less than 1/500 of the length in the axial direction between points that are laterally supported. Excessive local deformations shall be cause for rejection.

Bolted members shall be pinned or bolted and held together firmly during assembly without distorting or enlarging the holes. Poor matching of holes shall be cause for rejection.

Column bases shall be set level and to correct elevation with full bearing on foundation. Column bases shall be planed to obtain a satisfactory contact bearing. Compression joints that depend on contact bearing as part of the splice strength shall have the bearing surfaces of individual fabricated pieces prepared accordingly.

The frame shall be erected true and plumb in conformance with the requirements of the *Code of Standard Practice for Fabrication and Installation of Pultruded FRP Structures*. The out-of-plumbness of the centerline of any column shall not exceed 1/400 of the distance between column working points nor 5/16 inch (7.94 mm). Installation of permanent connections shall not be completed until the adjacent portions of the structure that are affected have been properly aligned.

Temporary bracing shall be provided, wherever necessary, to support construction loads and ensure stability, and shall be left in place as long as required for safety.

1.7.3 Quality Assurance and Control

The manufacturer, fabricator and contractor shall provide quality control procedures to the extent deemed necessary to ensure that all work is performed in accordance with this *Standard*.

(a) Inspection. Requirements for inspection by qualified representatives of the purchaser and the extent and standards of acceptance shall be clearly stated in the design documents. The fabricator and contractor shall cooperate with the inspector, providing access for inspection at all places where work is being done. The inspector shall schedule his inspection so as to minimize the disruption of the project. The fabricator, contractor and purchaser shall receive copies of all inspection reports.

(b) Laboratory testing. Where required by the qualified representative of the purchaser, the manufacturer shall submit for approval test results that demonstrate that constituent materials and the pultruded FRP structural members, components and systems are in conformance with the physical and mechanical property values specified in the contract documents. These tests shall be conducted by a testing laboratory approved by the Engineer of Record. For each property value, the number of batches from which test specimens were drawn, the number of tested specimens from each batch, the mean value, the minimum value, the maximum value, and the coefficient of variation shall be reported. The manufacturer and purchaser shall receive copies of all test reports.

(c) Rejection of work. The Engineer of Record shall have discretion to reject workmanship or material not in conformance with provisions of this *Standard* at any time during the progress of the work.

2. DESIGN REQUIREMENTS

This chapter contains general requirements for the analysis and design of pultruded FRP structural components and systems. The chapter is organized as follows:

- 2.1 Scope
- 2.2 Properties of sections
- 2.3 Design strength
- 2.4 Nominal strength and stiffness
- 2.5 Stability of frames and members
- 2.6 Design for serviceability
- 2.7 Design for ponding
- 2.8 Design for fatigue
- 2.9 Design of connections
- 2.10 Gross and net areas

2.1 Scope

This chapter contains general requirements that are applicable to all remaining chapters of this *Standard* for the analysis and design of pultruded FRP structures.

2.2 Properties of Sections

Pultruded FRP shapes and other products used for buildings and other structures shall conform to the requirements of ASTM D 3917 except as otherwise noted herein.

2.3 Design Strength

2.3.1 Basic Strength Requirement

The design strength shall be calculated as the product of the nominal resistance, R_n , adjusted for end-use conditions, a resistance factor, ϕ , and a time effect factor, λ :

$$R_u \leq \lambda \phi R_n \quad (2.3-1)$$

The nominal resistance shall be determined as stipulated in Section 2.4. The resistance factors are provided in Chapters 3 through 8 of this *Standard*. The time-effect factors that shall be used with the load combinations of Section 1.5.2 are defined in Table 2.3-1. When the full design load acts during the entire service life equal to or exceeding 50 years, the time effect factor shall be taken equal to 0.4.

Table 2.3-1 – Time effect factors, λ

| Load Combination (1.5.2(a)) | Equation number | Time Effect Factor (λ) |
|---|------------------------|---|
| 1.4D (permanent load) | (1.5-1) | 0.4 |
| 1.2D + 1.6L + 0.5(L _r or S or R) | (1.5-2) | 0.8 when L is from occupancy 0.6 when L is from storage 1.0 when L is from impact |
| 1.2D + 1.6(L _r or S or R) + (0.5L or 0.5W) | (1.5-3) | 0.75 |
| 1.2D + 1.0W + 0.5L + 0.5(L _r or S or R) | (1.5-4) | 1.0 |
| 1.2D + 1.0E + 0.5L + 0.2S | (1.5-5) | 1.0 |
| 0.9D + 1.0W | (1.5-6) | 1.0 |
| 0.9D + 1.0E | (1.5-7) | 1.0 |
| 1.5.2(b) – Flood loads | <i>na</i> | 0.75 |
| 1.5.2(c) – Atmospheric ice loads | <i>na</i> | 0.75 |

2.3.2 Prequalified FRP Building Products

Where the composition or configuration of structural components or systems is such that design by analysis cannot be performed in accordance with the provisions of this *Standard*, their structural performance and their compliance with the intent of this *Standard* shall be established from test results that are evaluated in accordance with the following:

- (a) Tests shall be conducted at a laboratory approved by the Engineer of Record.
- (b) Evaluation of predicted capacity shall be made on the basis of the mean (average) value of tests of at least ten (10) identical specimens. No test result shall be eliminated without a written rationale. The mean value of the test results shall be regarded as the reference strength, R_n .
- (c) The design strength of the tested component or system shall satisfy the following equation:

$$\lambda \phi_p R_n > 1.2 D + 1.6 L \quad (2.3-2)$$

in which R_n is as defined in Eq 2.4-1, and resistance factor, ϕ , is determined as:

$$\phi_p = \exp [- t_{n-1,p} V_R \sqrt{(1 + 1/n)}] \quad (2.3-3)$$

in which

R_n = nominal strength based on the reference strength in (a), adjusted for end use conditions;

V_R = coefficient of variation of test results;

$t_{n-1,p}$ = t-statistic with n-1 degrees of freedom, evaluated at $p = 0.99$ for members and $p = 0.999$ for connections;

n = sample size.

2.4 Nominal Strength and Stiffness

2.4.1 Nominal Strength

The nominal strength, adjusted for end-use conditions, shall be calculated as:

$$R_n = R_o C_1 C_2 \dots C_n \quad (2.4-1)$$

where R_o is the reference strength, and C_i is the applicable adjustment factors defined in Section 2.4.4 of this *Standard*.

The strength of a structural member assembled from connected components shall be determined using a transformed section analysis unless tests show that a higher strength can be substantiated. The elements of the composite member shall be connected so that the assembly acts as a unit. If the elements of the composite member are connected by fasteners, the finite deformation of the fasteners in developing composite action shall be taken into account; otherwise, the strength composite member shall be limited to the sum of the strengths of the individual elements.

2.4.2. Reference Strength and Stiffness

The reference strength and stiffness shall be determined based on the following conditions:

- (a) Short-term loading;
- (b) Ambient temperature of $73^\circ \pm 3^\circ\text{F}$ ($23^\circ \pm 2^\circ\text{C}$) and relative humidity of $50 \pm 10\%$;
- (c) Structural products that are untreated by protective coatings or systems;
- (d) New structural products;
- (e) Single members or connections without load sharing or composite action.

2.4.3 Statistical Basis for Reference Strength and Stiffness

The reference strength and stiffness shall be determined in accordance with ASTM D7290. A minimum of 10 samples shall be tested to determine the reference strength or stiffness.

(a) Reference strength. The strength of pultruded FRP composite structural members and components shall be assumed to be described by a two-parameter Weibull distribution. The reference strength shall equal the characteristic value, defined at the 80% lower confidence interval on the 5th-percentile of the Weibull distribution.

(b) Reference stiffness. The elastic modulus in the longitudinal direction and in-plane shear modulus shall be described by two-parameter Weibull distributions.

(1) Strength and stability. The reference stiffness shall equal the characteristic value of the governing Weibull distribution.

(2) Structural analysis. The reference stiffness shall equal the mean value of the governing Weibull distribution.

2.4.4 Adjustments to Reference Strength

Except where stipulated in other sections of this *Standard*, the nominal strength shall be determined by multiplying the reference strength by the adjustment factors set forth in Table 2.4-1.

(a) Adjustment factors for end-use. For sustained end-use conditions that differ from the reference conditions set forth in Sec. 2.4.2, adjustment factors shall be determined by tests stipulated by the Engineer of Record. In the absence of such tests, it is permitted to utilize the adjustment factors in this section.

C_M = moisture condition factor in Table 2.4-1 to account for sustained in-service moisture;

C_T = temperature factor in Table 2.4-1 to account for a sustained in-service temperature higher than 90°F (38°C) but less than $T_g - 40^\circ\text{F}$. For sustained temperatures in excess of 140°F (60°C), C_T shall be determined from tests stipulated by the Engineer of Record.

Table 2.4-1 Adjustment factors for end use conditions

| Reference Property | Moisture C_M | Temperature (°F) C_T for $(90 < T \leq 140)$ |
|----------------------|-------------------|---|
| Vinyl ester material | | |
| Strength | 0.85 | $1.7 - 0.008T$ |
| Elastic modulus | 0.95 | $1.5 - 0.006T$ |
| Polyester material | | |
| Strength | 0.80 | $1.9 - 0.010T$ |
| Elastic modulus | 0.90 | $1.7 - 0.008T$ |

C_{CH} = chemical environmental factor (high alkalinity, acidity), determined from interpolation or extrapolation of the results of ASTM C581 tests performed on the laminate exposed to the exposure chemical environment for a period of 1,000 hours, or as stipulated by the Engineer of Record.

(b) Adjustment factor for member strength in structural assemblies. It is permitted to modify the moment resistance of structural members and products in structural assemblies by the following factor:

C_{LS} = load sharing factor, equal to 1.20 for floors, walls, and roofs in uniformly loaded assemblies to account for the increase in strength of the assembly over the strength of an individual member, provided that the members are spaced no more than 24 in. (610 mm) on center, are not less than three in number, and are joined by sheathing or other load-distributing elements that are adequate to support the uniform design load.

(c) Adjustment factor for member stiffness in structural assemblies. It is permitted to modify the reference stiffness of structural members that act as part of uniformly loaded structural assemblies by the following factor:

C_{CA} = composite action factor equal to 1.20 for computing deflections in uniformly loaded

floors, walls, and roofs to account for the increase in assembly stiffness when the members are constrained to act in a composite fashion, provided that the members are spaced no more than 24 in. (610 mm) on center, are not less than three in number, and are joined by sheathing or other load-distributing elements that are adequate to ensure composite action.

2.4.5 Notches, Holes and Other Stress Concentrations

When notches, openings, copes and other stress concentrations are present in a structural member, provision shall be made for their effect on strength. Unless tests show that a higher strength can be substantiated, the following limits shall apply:

(a) Columns:

When notches or holes are located in the middle half of the distance between inflection points of the deflected shape, the net area shall be used in computing the slenderness ratio.

(b) Beams:

1. The flexural resistance at any notched section shall not exceed the flexural resistance of the net section at the location of the notch.
2. When a notch occurs on the tension face of a beam within the middle half of the distance between inflection points of the deflected shape, the flexural resistance of the beam shall be based on the flexural strength of the net section at the location of the notch.
3. Openings in beam webs shall not be permitted within a distance equal to the depth of the beam from its supports.

2.5 Stability of Frames and Members

2.5.1 General Requirements

Stability shall be provided for the structure as a whole and for each component within the structure. The design shall take into account load effects resulting from the deflected shape of the structure or of individual components of the lateral load resisting system. All deformations of member and connections that contribute to the lateral displacements of the system shall be considered in the stability analysis.

2.5.2 Design Requirements for Frame Stability

Lateral stability of structural frames shall be provided by braced frames, shear walls, and/or other equivalent lateral load-resisting systems. The overturning effects of drift and the stabilizing effects of gravity loads when lateral forces act shall be taken into account.

Structural analysis shall establish that the structural system is adequate to prevent member buckling and to maintain the lateral stability of the structure under the factored load combinations in Section 1.5.2. A notional lateral load equal to $0.0025 \sum P_i$, in which $\sum P_i$ = gravity load applied to the frame at level i , shall be applied in all load combinations in addition to any other lateral loads. Force transfer and load sharing between elements of the framing system shall be considered. Axial deformations of all members in the vertical bracing system shall be included in the lateral stability analysis.

(a) Braced Frames. In braced-frame structural systems, where lateral stability is provided solely by diagonal bracing, shear walls or equivalent means, the effective length factor, K , for compression members shall be set equal to unity (1.0) unless a rational analysis shows that the end restraint conditions justify the use of a smaller value. It is permitted to design the columns, beams and diagonal members of braced frame systems as if the frame is a vertically cantilevered truss with simple connections, and to assume that the vertical bracing system functions with any shear walls, floor or roof systems that are integral to the braced frame.

(b) Unbraced Frames. In frames where lateral stability depends on the flexural stiffness of beams, columns and their connections, the effective length factor, K , of compression members shall be determined by rational analysis. $P-\Delta$ effects due to load on gravity columns shall be transferred to the lateral load-resisting system and shall be considered in the calculation of its required strength.

2.5.3 Required Strength of Frames

The required strength of frames shall be determined using a second-order analysis. It is permitted to perform the approximate second-order analysis described in this section, in which the forces and deflections from a first-order elastic analysis are amplified, to meet this requirement.

The required strength in axial compression, P_u , and bending, M_u , for beam-columns, connections and connected members shall be determined from the following equation:

$$M_u = B_1 M_{nt} + B_2 M_{lt} \quad (2.5-1)$$

$$P_u = P_{nt} + P_{lt} \quad (2.5-2)$$

where

P_{nt}, M_{nt} = required axial and flexural strengths in a member assuming that there is no lateral translation of the frame;

P_{lt}, M_{lt} = required axial and flexural strengths in a member as a result of lateral translation of the frame only;

$$B_1 = C_m / (1 - P_u/P_e) \geq 1.0 \quad (2.5-3)$$

$$B_2 = 1 / (1 - [\Sigma P_u / \Sigma HL] \Delta_1) \quad (2.5-4)$$

C_m = a coefficient based on first-order elastic analysis, assuming no translation of the frame, the value of which shall be taken as follows:

- (a) For compression members not subject to transverse loading between points of support in the plane of bending:

$$C_m = 0.6 - 0.4 (M_1/M_2) \quad (2.5-5)$$

in which M_1/M_2 is the ratio of smaller to larger moments at the ends of that portion of the member that is unbraced in the plane of bending. M_1/M_2 is positive when the member is bent in double curvature, negative when bent in single curvature.

- (b) For compression members subjected to transverse loading between points of support, $C_m = 1.0$.

P_e = Euler buckling load in the plane of bending, determined in accordance with Chapter 4.

ΣP_u = required axial strength of all columns in a story, based on first-order elastic analysis;

Δ_1 = lateral drift determined from first-order elastic analysis;

ΣH = sum of all story horizontal forces producing lateral drift, Δ_1 ;

L = story height

2.5.4 Design Requirements for Member Stability

Stability of individual members shall be determined by the requirements of Chapters 4, 5 and 6. Where elements are designed to function as braces at points that define the unbraced length of columns and beams, the bracing system shall have adequate strength and stiffness to limit member translation or rotation at the braced points.

2.5.5 Bracing of Members and Frames

Bracing shall be designed to enable development of member design strength based on the unbraced length between the braces unless analysis or test results demonstrate that smaller values are justified. Braces shall restrain lateral bending or twisting of a loaded beam, column or truss member and shall not cause local crippling at points of attachment. The evaluation of the strength and stiffness furnished by a brace shall include its member and geometric properties, as well as the effects of connections and anchorage details.

The brace strengths presented in this section are based on the assumption that the bracing is perpendicular to the members to be braced. For inclined or diagonal bracing, the brace strength and stiffness shall be adjusted for the angle of inclination.

(a) Bracing of Beams. Stability of beams between brace points and at points of support shall be provided by bracing that prevents twist of the beam section at the brace points and at points of inflection. In members subjected to double-curvature bending, the inflection point shall not be considered to be a brace point. Bracing shall be provided by lateral bracing, torsional bracing, or a combination of the two.

(1) Lateral bracing. The brace strength, P_{br} , and stiffness, K_{br} , shall equal or exceed

$$P_{br} = 0.02 M_u C_d / h_o \quad (2.5-6)$$

$$K_{br} = 12 M_u C_d / L_b h_o \quad (2.5-7)$$

in which:

M_u = required flexural strength (k-in)

C_d = 1 for flexure in single-curvature; 2 for flexure in double-curvature.

L_b = distance between braces (in)

h_o = distance between centroids of flanges (in)

(2) Torsional bracing. It is permitted to attach torsional bracing at any location on the cross section. The connection between a torsional brace and the beam shall be designed to support the required moment, M_{br} :

$$M_{br} = 0.024 M_u L / (n C_b L_b) \quad (2.5-8)$$

in which:

M_u = required flexural strength (k-in)
 L = span length (in)
 n = number of braced points within the span
 C_b = modification factor defined in Chapter 5
 L_b = laterally unbraced length (in)

The required bracing stiffness is:

$$K_{br} = K_T / (1 - K_T/K_{sec}) \quad (2.5-9)$$

where:

$$K_T = 3.2 LM_u^2 / (nE_L I_y C_b^2) \quad (2.5-10a)$$

$$K_{sec} = 3.3 E_L [1.5 h_o t_w^3 + t_s b_s^3] / 12 h_o \quad (2.5-10b)$$

and

K_T = brace stiffness, excluding web-distortion (k-in/radian)
 K_{sec} = web distortional stiffness, including the effect of any web transverse stiffeners (k-in/radian)
 E_L = elastic modulus in longitudinal direction (k/in²)
 I_y = out-of-plane moment of inertia (in⁴)
 t_w = beam web thickness (in)
 t_s = web stiffener thickness (in)
 b_s = stiffener width, per side of beam, for web stiffener (in)

(b) Bracing of columns. The brace strength, P_{br} , and stiffness, K_{br} , shall equal or exceed

$$P_{br} = 0.01 P_u \quad (2.5-11)$$

$$K_{br} = 10 P_u / L_b \quad (2.5-12)$$

in which:

P_u = required axial strength (k)
 L_b = distance between braces (in)

(c) Bracing of frames. Where lateral stability is provided by diagonal bracing, shear walls, panels or equivalent means, the required minimum story or panel bracing shear force, P_{br} , and story or panel shear stiffness, K_{br} , shall be taken as:

$$P_{br} = 0.004 \Sigma P_u \quad (2.5-13)$$

$$K_{br} = 3 \Sigma P_u / L \quad (2.5-14)$$

where

ΣP_u = sum of the factored column axial loads acting on the story or panel supported by the bracing (k)

L = story height or panel spacing (in)

2.6 Design for Serviceability

Serviceability limit states which include, but are not limited to, short-term deflection, vibration, creep, dimensional changes and the effects of deterioration, shall be considered in design. Limiting values of structural behavior for serviceability shall be chosen with due regard to the intended function of the structure.

Serviceability shall be checked using realistic loads for the serviceability limit state of concern. The *adjusted mean values* of longitudinal elastic modulus E_L and shear modulus G_{LT} shall be used in determining stiffnesses for calculating deflections of structural systems and components.

2.6.1 Deformations

Deflections and rotations of structural members and systems under specified service loads shall not impair the serviceability of the structure, nor cause damage to structural elements or nonstructural appurtenances and attachments.

Where required for acceptable building performance, structural systems and components shall be designed to accommodate long-term irreversible deflections under sustained load. The total deflection, Δ , shall be calculated as follows:

$$\Delta = \Delta_{st} K_{cr}(t) \quad (2.6-1)$$

in which Δ_{st} = instantaneous deflection due to gravity loads in combination 1.5-10, $K_{cr}(t)$ is a deflection amplification factor defined as:

$$K_{cr}(t) = 1 + t^{1/4} / 6 \quad (2.6-2)$$

and t is the required service period of service, expressed in years.

2.6.2 Vibration

The effect of vibration of floors or the structural system on the comfort of the occupants and the function of the structure shall be considered. Sources of vibration to be considered include pedestrian loading, wind-induced motion of the building, and vibrating machinery.

2.6.3 Connection Slip

Structural design shall consider the effects of slip of bolted connections where connection slip may cause deformations that impair the serviceability of the structure.

2.6.4 Expansion and Contraction

Dimensional changes in a structural system due to variations in temperature leading to thermal expansion or contraction, relative humidity and other effects shall not impair the serviceability of the structure.

2.6.5 Deterioration

Effects due to environmental deterioration from exposure to chemicals and alkalinity shall not impair the serviceability of the structure.

2.7 Design for Ponding

Roof systems shall be investigated by structural analysis to ensure adequate strength, stability and stiffness under ponding conditions unless the roof is provided with a slope of 1/4 inch per ft (20 mm per m) or greater toward points of free drainage or a roof drainage system is provided that is adequate to prevent the accumulation of water. Drains and parapets shall be detailed to minimize the occurrence of clogging and unplanned retention of water. Additional provisions for ponding design (such as that caused by failure of the primary drainage of the roof system, may be required by the applicable building code.

The roof system shall be considered to be stable and no further investigation shall be needed if

$$C_p + C_s < 0.3 \quad (2.7-1)$$

in which:

$$C_p = 92 L_s L_p^4 / (E_L I_p) \quad (2.7-2)$$

$$C_s = 92 S L_s^4 / (E_L I_s) \quad (2.7-3)$$

L_p = column spacing in direction of primary member (ft)

L_s = column spacing perpendicular to direction of primary member (ft)

S = spacing of secondary members (ft)

E_L = elastic modulus in longitudinal direction (lb/in²)

I_p = moment of inertia of primary members (in⁴)

I_s = moment of inertia of secondary members (in⁴)

2.8 Design for Fatigue

Fatigue shall be considered in the design of members and connections subjected to repeated loading, where required by the authority having jurisdiction.

The stress range, ΔS , used in fatigue analysis, expressed as a ratio of the tensile strength, shall be defined by the magnitude of the change in stress due to the application or removal of the service (unfactored) live load. In bolted connections subjected to tension, the calculated stresses shall include the effect of prying action, if applicable. The stress range shall not exceed the following stress range limit:

$$(\Delta S)_{\text{limit}} = (C/N_f)^{1/m} \quad (2.8-1)$$

in which C = constant defined in Table 2.8-1 that depends on the geometry of the fatigue-critical detail and N_f is the number of stress cycles that the structure must sustain during its service period. In fatigue-critical details, re-entrant corners at cuts and copes shall form a radius of not less than 3/8 in (9.5 mm).

Table 2.8-1 Fatigue design parameters

| Category | Description of structural detail | m | C |
|----------|---|-----|------|
| I | Plain material away from re-entrant corners or fasteners | 8.5 | 10.0 |
| II | Material at net section of bolted joints designed on the basis of bearing resistance, where the resultant force is concentric to the fastener group | 8.5 | 0.6 |
| III | Material at net section of bolted joints not in Category II, or at points of attachment of brackets, stiffeners and other elements | 8.5 | 0.08 |
| IV | Details not included in I, II or III | 8.5 | 0.01 |

Fatigue need not be considered for wind or seismic effects on the structural framing systems, roofing or cladding of buildings, nor if the expected number of stress cycles during the service life of the structure is 4,000 or less.

2.9 Design of Connections

Connections, connected members, connecting elements and connectors (fasteners and adhesives) shall be proportioned in accordance with the provisions of Chapter 8 so that their design strength equals or exceeds the required strength determined by structural analysis for the load combinations stipulated in Section 1.5. The forces and deformations shall be consistent with the intended performance of the connection and the assumptions made in the structural analysis. Simple connections shall have sufficient rotation capacity to accommodate the rotation determined by the structural analysis under the design loads without overloading the connecting elements.

Fasteners and connecting elements in pultruded FRP structures designed in accordance with the provisions of this Standard shall be metallic unless otherwise prequalified under the requirements of Section 2.3.2.

Groups of fasteners designed to transmit axial forces shall be sized and located so that the axis of each connected member intersects the center of resistance of the group of fasteners, unless provision is made for the bending moment induced by the transmission of eccentric forces from an unsymmetrical fastener arrangement. The effects of these eccentric forces on fastener and member loads shall be analyzed in accordance with established principles of mechanics.

Slotted holes shall be aligned normal to the direction of the primary application of the applied force.

For connections with only one bolt, structural integrity shall be provided by adhesive bonding or other approved measures.

Notwithstanding the required connection strength determined from structural analysis, the design strength of structural connections shall not be less than 1 kip (4.5 kN).

2.10 Gross and Net Areas

2.10.1 Gross Area

The gross area, A_g , of a pultruded FRP member at any point is the sum of the areas of each element comprising the member, measured normal to the longitudinal axis of the member.

2.10.2 Net Area

The net area of a pultruded FRP member, A_n , shall be obtained by deducting the area of all material removed by drilling or other means from the gross area, unless otherwise specified. The net area shall not be less than 75% of the gross area.

In determining area of material removed for computing net area for tension or shear, the width of a bolt hole shall be taken as 1/16 in (1.6 mm) greater than the nominal dimension of the hole.

For a chain of holes extending across a part in any diagonal or zigzag line, the net width of the part shall be determined by deducting from the gross width the sum of all hole widths in the chain and adding, for each gage space in the chain, the quantity $s^2/4g$, in which

s = longitudinal center-to-center spacing (pitch) of any two consecutive holes

g = transverse center-to-center spacing (gage) between fastener lines.

The gage for holes in adjacent legs of angles shall be the sum of the gages from the back of the angles less the thickness of the angle.

2.10.3 Effective Net Area.

The effective net area of tension members shall be determined as:

$$A_e = U A_n \quad (2.10-1)$$

in which U = shear lag factor.

When tension is transmitted directly through each of the cross-sectional elements, $U = 1.0$.

When tension is transmitted by fasteners, or a combination of fasteners and adhesives, through some, but not all, cross-sectional elements of the member, U shall be determined as follows:

- (a) For members in which the connection has three (3) or more fasteners per line in the direction of tension force, $U = 0.80$.
- (b) For members having only two (2) fasteners in the line of tension force, $U = 0.70$.

3. DESIGN OF TENSION MEMBERS

This chapter provides provisions for design of tension members. It is organized as follows:

- 3.1 Scope
- 3.2 General Provisions
- 3.3 Nominal Axial Tensile Strength
- 3.4 Built-Up Members
- 3.5 Slenderness Limitations

3.1 Scope

The design provisions of this chapter apply to pultruded FRP structural shapes in tension through the shear center along the member length. Those members under tension loads parallel to the longitudinal axis that are not passing through the center of gravity or shear center of the structural shape shall be designed for combined tension and other loads. Provisions of this chapter are applicable for cases where tension is applied parallel to a member's longitudinal axis and not perpendicular to the longitudinal axis. This chapter does not cover the design of pultruded FRP structural shapes with unidirectional reinforcements such as rods. Such shapes shall be prequalified according to the standards in Section 2.3.2. The provisions in the chapter are not applicable to members reinforced with stitched fabrics.

3.2 General Provisions

A member under axial tension shall satisfy the following equation:

$$P_u \leq \lambda \phi P_n \quad (3.2-1)$$

where,

P_u = required axial tensile strength due to factored loads

P_n = nominal axial tensile strength including adjustment factors as defined in Section 2.4, as necessary

λ = time effect factor as defined in Table 2.3-2

ϕ = resistance factor for failure of a section under tension rupture of the material shall be taken as 0.65

3.3 Nominal Axial Tensile Strength

The nominal axial tensile strength, P_n of a tension member shall be the lowest of the following limit states:

- (a) For tensile rupture in the gross section:

$$P_n = F_n A_g \quad (3.3-1)$$

(b) For tensile rupture in the net section with open-holes:

$$P_n = 0.7 F_n A_e \quad (3.3-2)$$

where,

F_n = nominal tensile strength from the characteristic value of coupon tests

A_g = gross cross sectional area

A_e = effective net cross sectional area as per Section 2.10.3 including shear lag effects

3.4 Built-Up Members

In a built-up tension member composed of two or more pultruded profiles, the longitudinal spacing of connectors between components shall limit the slenderness ratio L/r to 300, where L is the laterally unbraced length of a member and r is the radius of gyration about the weak axis. The use of adhesives alone shall not be permitted in built-up tension members. For limitations on the longitudinal spacing of connectors between members, refer to Chapter 8.

The design strength of the built-up member meeting the following requirements shall be determined from rational analysis: the ends of built-up member composed of two or more pultruded components shall be connected by means of bolts as well as adhesive, and shall require a connected length not less than 2 times the maximum width of the member.

3.5 Slenderness Limitations

For members designed on basis of tension, the slenderness ratio (L/r) of a tension member shall not exceed 300, where L is the laterally unbraced length of a member and r is the radius of gyration about the weak axis.

4. DESIGN OF COMPRESSION MEMBERS

This chapter provides provisions for design of compression members. It is organized as follows:

- 4.1 Scope
- 4.2 General provisions
- 4.3 Slenderness and effective length considerations
- 4.4 Factored critical stress in compression for common sections
- 4.5 Compression strength for members with other cross sections
- 4.6 Compression strength for built-up members

4.1 Scope

The design provisions of this chapter apply to pultruded FRP structural shapes subjected to an axial compression force applied through the centroidal axis of the member. If axial compression is combined with bending, such members shall be designed according to the provisions established in Chapter 6.

4.2 General Provisions

Compression members shall be designed such that

$$P_u \leq \lambda \phi_c P_n \leq 0.7 \lambda F_L^c A_g \quad (4.2-1)$$

where

$$\phi_c P_n = \phi_c F_{cr} A_g \quad (4.2-2)$$

and

$$P_s \leq \phi_0 \frac{\pi^2 E_L}{\left(\frac{KL_e}{r}\right)^2} A_g \leq 0.3 F_L^c A_g \quad (4.2-3)$$

P_u = Required compression strength due to factored loads

λ = Time effect factor specified in Table 2.3-1

P_n = Nominal axial compression strength determined in accordance with Sections 4.4 and 4.5 as adjusted by the requirements of Section 2.4.

$\phi_c F_{cr}$ = Factored critical stress defined in 4.4.

P_s = Compression force due to serviceability load combinations defined in 1.5.3

A_g = Gross area of cross section

E_L = Characteristic value of the longitudinal compression elastic modulus of the flange or web, whichever is smaller

F_L^c = Minimum longitudinal compression material strength of all elements comprising the cross section

$\frac{KL_e}{r}$ = Compression member effective slenderness ratio defined in 4.3.3.

ϕ_0 = Reduction factor that accounts for the initial out-of-straightness of the compression member, defined as follows

$$\phi_0 = 1 - 500 \frac{\delta_0}{L} \quad (4.2-4)$$

where

$\frac{\delta_0}{L}$ = Initial out-of-straightness fraction guaranteed by the pultrusion manufacturer. Where stipulated by the Engineer of Record, the initial out-of-straightness fraction shall be determined by an approved testing laboratory in accordance with section 1.7.3

4.3 Slenderness and Effective Length Considerations

4.3.1 Effective Member Length

The effective member length, L_e , of an axially loaded compression member shall be taken as the center-to-center distance between lateral supports.

4.3.2 Effective Length Factor

The effective length factor for an axially loaded compression member shall be determined according to 2.5.2.

4.3.3 Compression Member Effective Length

The effective length of a compression member shall be taken as KL_e where K is the member effective length factor defined in Section 4.3.2 and L_e is the effective member length defined in 4.3.1.

4.3.4 Compression Member Effective Slenderness Ratio

The effective slenderness ratio, KL_e / r of a compression member is defined as the ratio of the effective length of the compression member as defined in Section 4.3.3 to the radius of gyration corresponding to the direction being considered.

The slenderness ratio, $\frac{KL_e}{r}$, of a compression member shall not exceed either $1.4 \sqrt{\frac{E_L A_g}{P_D}}$ or 300, where

P_D is the compression force due to the unfactored dead load.

4.4 Factored Critical Stress in Compression for Common Sections

The factored critical stress, $\phi_c F_{cr}$, shall be determined as follows:

4.4.1 Geometrically Symmetric I-Shaped Sections

For I-shaped sections in which the x- and y-axes are the geometric axes of symmetry, the factored critical stress, $\phi_c F_{cr}$, shall be taken as the lowest of the values of $\phi_c F_{crx}$, $\phi_c F_{cry}$, $\phi_c F_{crf}$ and $\phi_c F_{crw}$ defined by the equations

$$F_{crx} = \frac{\pi^2 E_L}{\left(\frac{K_x L_x}{r_x} \right)^2} \text{ and } \phi_c = 0.7 \quad (4.4-1)$$

$$F_{cry} = \frac{\pi^2 E_L}{\left(\frac{K_y L_y}{r_y} \right)^2} \text{ and } \phi_c = 0.7 \quad (4.4-2)$$

$$F_{crf} = \frac{G_{LT}}{\left(\frac{b_f}{2t_f} \right)^2} \text{ and } \phi_c = 0.8 \quad (4.4-3)$$

$$F_{crw} = \frac{\left(\frac{\pi^2}{6} \right) \left[\sqrt{E_{L,w} E_{T,w} + \nu_{LT} E_{T,w} + 2G_{LT}} \right]}{\left(\frac{h}{t_w} \right)^2} \text{ and } \phi_c = 0.8 \quad (4.4-4)$$

where

F_{crx} = the elastic flexural buckling stress about the x -axis

F_{cry} = the elastic flexural buckling stress about the y-axis.

F_{crf} = local flange buckling stress

F_{crw} = local web buckling stress

K_x = the effective length factor corresponding to the x-axis

K_y = the effective length factor corresponding to the y-axis

L = Laterally unbraced length of member

r = Governing radius of gyration about the axis of buckling

E_L = Characteristic value of longitudinal compression elastic modulus of the flange or web, whichever is smaller

$E_{T,w}$ = Characteristic value of the compression elastic modulus of the web in the direction perpendicular to the pultrusion direction

ν_{LT} = Poisson's ratio of the web plate element associated with transverse deformation when compression is applied in the longitudinal direction.

G_{LT} = Characteristic value of the in-plane shear modulus

4.4.2 T-Shaped Sections

For T-shaped sections in which the y-axis is the axis of symmetry of the geometric shape, the factored critical stress, $\phi_c F_{cr}$, shall be taken as the lowest of the values of $\phi_c F_{crf}$, $\phi_c F_{crw}$, $\phi_c F_{crx}$, and $\phi_c F_{ft}$ as defined by the equations:

$$F_{crf} = \frac{G_{LT}}{\left(\frac{b_f}{2t_f}\right)^2} \quad \text{and} \quad \phi_c = 0.8 \quad (4.4-5)$$

$$F_{crf} = \frac{G_{LT}}{\left(\frac{d}{t_w}\right)^2} \quad \text{and} \quad \phi_c = 0.8 \quad (4.4-6)$$

$$F_{crx} = \frac{\pi^2 E_L}{\left(\frac{K_x L_x}{r_x}\right)^2} \quad \text{and} \quad \phi_c = 0.7 \quad (4.4-7)$$

$$F_{ft} = \left(\frac{F_{cry} + F_{crz}}{2H}\right) \left[1 - \sqrt{1 - \frac{4HF_{cry}F_{crz}}{(F_{cry} + F_{crz})^2}}\right] \quad \text{and} \quad \phi_c = 0.7 \quad (4.4-8)$$

where

$$F_{cry} = \frac{\pi^2 E_L}{\left(\frac{K_y L_y}{r_y}\right)^2}$$

$$F_{crz} = \frac{1}{R_p^2} \left[D_J + D_w \left(\frac{\pi}{L}\right)^2 \right]$$

$$H = 1 - \frac{y_p^2}{R_p^2}$$

$$y_p = \frac{h_w}{2 \left(1 + \frac{b_f t_f}{h_w t_w} \right)}$$

$$R_p^2 = \frac{1}{b_f t_f + h_w t_w} \left[\frac{b_f t_f}{12} (b_f^2 + t_f^2) + h_w t_w \left(\frac{h_w^2}{3} + \frac{t_w^2}{12} \right) \right]$$

$$D_J = \frac{G_{LT}}{3} (b_f t_f^3 + h_w t_w^3)$$

$$D_w = E_L \left(\frac{b_f^3 t_f^3}{144} + \frac{h_w^3 t_w^3}{36} \right)$$

F_{crx} = the critical elastic flexural buckling stress about the x -axis

F_{cry} = the elastic flexural buckling stress about the y-axis.

F_{crz} = the critical torsional buckling stress

F_{ft} = the elastic flexural-torsional buckling stress.

F_{crf} = local flange buckling stress

F_{crw} = local web buckling stress

D_J = torsional rigidity of the section

D_w = warping rigidity of the section

R_p = polar radius of gyration about the center of twisting of the cross section

G_{LT} = Characteristic value of the in-plane shear modulus of the flange.

E_L = Characteristic value of the longitudinal compression elastic modulus of the flange or stem, whichever is smaller

h_w = Distance between the centerline of the flange and the outer face of the stem

b_f = Flange width

t_f = Flange thickness

t_w = Stem thickness

4.4.3 Single Angle Sections with Equal Legs

For equal-leg angle sections in which the y-axis is the axis of symmetry of the geometric shape, the factored critical stress, $\phi_c F_{cr}$, shall be taken as the lower of the values of $\phi_c F_{crx}$ and $\phi_c F_{crft}$ defined by the equations:

$$F_{crx} = \frac{\pi^2 E_L}{\left(\frac{KL_x}{r_x}\right)^2} \text{ and } \phi_c = 0.7 \quad (4.4-9)$$

$$F_{crt} = \frac{G_{LT}}{\left(\frac{b}{t}\right)^2} \text{ and } \phi_c = 0.8 \quad (4.4-10)$$

where

E_L = Characteristic value of the longitudinal compression elastic modulus

G_{LT} = Characteristic value of the in-plane shear modulus

b = Outside width of leg in compression

t = Angle leg thickness

r_x = Radius of gyration about the principal x-axis

4.4.4 Single Angle Sections with Unequal Legs

For unequal leg single angle sections subjected to compression, the factored flexural-torsional buckling strength, $\phi_c F_{cr}$, shall be computed by rational analysis.

4.4.5 Square and Rectangular Tube Sections

The factored critical stress, $\phi_c F_{cr}$, shall be taken as the lower of the values of $\phi_c F_{cr}$ and $\phi_c F_{crw}$ defined by the equations:

$$F_{cr} = \frac{\pi^2 E_L}{\left(\frac{KL}{r}\right)^2} \text{ and } \phi_c = 0.7 \quad (4.4-11)$$

$$F_{crw} = \frac{\left(\frac{\pi^2}{6}\right) \left[\sqrt{E_{L,w} E_{T,w}} + \nu_{LT} E_{T,w} + 2G_{LT} \right]}{\beta_w^2} \text{ and } \phi_c = 0.8 \quad (4.4-12)$$

where

$\frac{KL}{r}$ = Governing effective slenderness ratio of the section corresponding to the axis of buckling

E_L = Minimum longitudinal compression elastic modulus, whichever is smaller, of all elements comprising the cross section

$E_{L,w}$ = Characteristic value of the longitudinal compression modulus of the element under consideration

$E_{T,w}$ = Characteristic value of the transverse compression modulus of the element under consideration

G_{LT} = Characteristic value of the in-plane shear modulus of the element under consideration

ν_{LT} = Poisson's ratio associated with transverse deformation when compression is applied in the longitudinal direction

β_w = Maximum width-to-thickness ratio, whichever is larger, of all elements comprising the tube section

4.4.6. Circular Tube Sections

The factored critical stress, $\phi_c F_{cr}$, shall be taken as the minimum value computed from the following equations:

$$F_{cr} = \frac{\pi^2 E_L}{\left(\frac{KL}{r}\right)^2} \quad \text{and} \quad \phi_c = 0.7 \quad (4.4-13)$$

$$F_{cr} = \frac{\sqrt{\frac{2}{3} G_{LT} \sqrt{E_L E_T}}}{\left(\frac{D}{2t}\right)} \leq \frac{\sqrt{\frac{E_L E_T}{3}}}{\left(\frac{D}{2t}\right)} \quad \text{and} \quad \phi_c = 0.8 \quad (4.4-14)$$

where

K = Effective length factor

L = Laterally unbraced length of member

r = Radius of gyration about the axis of buckling

E_L = Characteristic value of the longitudinal compression elastic modulus

E_T = Characteristic value of the transverse compression elastic modulus

G_{LT} = Characteristic value of the in-plane shear modulus

D = Outside diameter of the tube

t = tube wall thickness

4.4.7 Square, Rectangular, and Circular Solid Sections

The factored critical stress, $\phi_c F_{cr}$, shall be defined by the equations

$$F_{cr} = \frac{\pi^2 E_L}{\left(\frac{KL}{r}\right)^2} \quad \text{and} \quad \phi_c = 0.7 \quad (4.4.15)$$

where

E_L = Minimum characteristic value of the longitudinal compression elastic modulus, whichever is smaller, of all elements comprising the cross section.

$\frac{KL}{r}$ = Governing effective slenderness ratio of the section corresponding to the axis of buckling

4.5 Compression Strength for Members with Other Cross-Sections

The nominal axial compression strength of a member having a geometric cross section that differs from those addressed in 4.4 shall be determined from either tests in accordance with Section 2.3.2 or by rational analysis.

4.6 Compression Strength for Built-Up Members

4.6.1 Design Strength

The design strength of the built-up member meeting the requirements of 4.6.2 shall be determined from rational analysis.

4.6.2 Detailing Requirements

The ends of built-up compression members composed of two or more pultruded components shall be connected by means of combined bolts and adhesive having a length not less than two times the maximum width of the member.

Along the length of built up compression members between the end connections as specified in the previous paragraph, longitudinal spacing of intermittent connectors shall be provided at such a longitudinal spacing that the slenderness ratio of the individual member between two adjacent connectors does not exceed $\frac{3}{4}$ times the governing slenderness ratio of the built-up members.

5. DESIGN OF MEMBERS FOR FLEXURE & SHEAR

This chapter provides design provisions for flexural members subjected to bending moments and transverse shear forces due to transverse distributed and concentrated forces. It is organized as follows:

- 5.1 Scope
- 5.2 Design of Members for Flexure
- 5.3 Design of Members for Shear
- 5.4 Design of Members for Concentrated Forces
- 5.5 Design for Copes, Notches, Holes and Openings
- 5.6 Design of Flexural Members for Serviceability

5.1 Scope

The design provisions of this chapter apply to pultruded FRP structural shapes subjected to transverse loads and bending about one principal axis including doubly-symmetric members such as I-shaped, square tube, rectangular tube and “back-to-back” channel members, and singly-symmetric members such as tees, channels and “back to back” equal or unequal leg angles provided they are loaded through the shear center. Connections of back-to-back members along their lengths shall be sufficient to ensure that they act as composite members. The provisions presented in this chapter apply to both homogeneous and non-homogeneous pultruded FRP structural shapes. Non-homogeneous pultruded FRP structural shapes have properties in the flange(s) which are different from the properties in the web(s).

5.2 Design of Members for Flexure

5.2.1 Design Basis

When subjected to transverse loads that cause the member to bend about the plane of the neutral axis (referred to as the plane of bending), members shall be designed such that

$$M_u \leq \lambda \phi M_n \quad (5.2.1-1)$$

where

M_u = Required flexural strength, kip-in. (N-mm)

ϕ = Resistance factor for flexure depending on the mode of failure as defined in Sections 5.2.2, 5.2.3 and 5.2.4

λ = Time effect factor specified in Table 2.3-1

M_n = Nominal flexural strength, including adjustment factors of Section 2.4., determined in accordance with Sections 5.2.2, 5.2.3 and 5.2.4, kip-in. (N-mm)

The factored nominal flexural strength of members, ϕM_n shall be taken as the smallest strength obtained from the limit states of (a) material rupture, (b) local buckling, and (c) lateral-torsional buckling.

5.2.2 Nominal Strength of Members due to Material Rupture

For failure of members due to rupture of the material in tension or compression in the flanges or webs of members, the resistance factor shall be taken as $\phi = 0.65$.

The nominal flexural strength of members due to material rupture shall be determined as,

$$M_n = \min \left(\frac{F_{L,f} (E_{L,f} I_f + E_{L,w} I_w)}{y_f E_{L,f}}, \frac{F_{L,w} (E_{L,f} I_f + E_{L,w} I_w)}{y_w E_{L,w}} \right) \quad (5.2.2-1)$$

User Note: For members that have longitudinal elastic moduli in the flanges and webs within 15% of each other equation 5.2.2-1 becomes:

$$M_n = \frac{F_L I}{y}$$

where

$F_{L,f}$ = Characteristic longitudinal strength of the flange (in tension or compression), ksi (MPa)

$F_{L,w}$ = Characteristic longitudinal strength of the web (in tension or compression), ksi (MPa)

F_L = Characteristic longitudinal strength (in tension or compression) of the member, ksi (MPa)

$E_{L,f}$ = Characteristic longitudinal modulus of the flange, ksi (MPa)

$E_{L,w}$ = Characteristic longitudinal modulus of the web, ksi (MPa)

I_f = Moment of inertia of the flange(s) about the axis of bending, in⁴ (mm⁴)

I_w = Moment of inertia of the web(s) about the axis of bending, in⁴ (mm⁴)

I = Moment of inertia of the member about the axis of bending, in⁴ (mm⁴)

y_f = Distance from the neutral axis to the extreme fiber of the flange, in. (mm)

y_w = Distance from the neutral axis to the extreme fiber of the web, in. (mm)

y = Distance from the neutral axis to the extreme fiber of the member, in. (mm)

5.2.3 Nominal Strength of Members due to Local Instability

For failure due to local instability in the flanges or webs of members as a result of buckling due to in-plane compressive stresses, the resistance factor shall be taken as $\phi = 0.80$.

All members shall be checked for local buckling of their flange(s) and web(s) that are subjected to compressive stresses due to flexure of the member. Local buckling does not have to be considered in cases when the flange or web in compression is continuously restrained from local instability by an adjacent stiff structural member.

The nominal flexural strength of an I, C, T or box section governed by local instability of flange or web shall be determined as follows:

- (a) Compression flange local buckling

$$M_n = f_{cr} \frac{E_{L,f} I_f + E_{L,w} I_w}{y E_{L,f}} \quad (5.2.3-1a)$$

(b) Web local buckling

$$M_n = f_{cr} \frac{E_{L,f} I_f + E_{L,w} I_w}{y E_{L,w}} \quad (5.2.3-1b)$$

User Note: For members that have longitudinal elastic moduli in the flanges and webs within 15% of each other equation 5.2.3-1 becomes:

$$M_n = \frac{f_{cr} I}{y}$$

where

f_{cr} = Critical buckling stress taken as the minimum of (a) *compression flange local buckling* and (b) *web local buckling* determined from sections:

- 5.2.3.1 Singly and Doubly Symmetric I-shaped Members Bent About Their Strong Axis;
- 5.2.3.2 Singly Symmetric Channels Bent About Their Strong Axis
- 5.2.3.3 Tees and Back-to-back Angles Bent About Their Strong Axis
- 5.2.3.4 Square and Rectangular Box Members
- 5.2.3.5 Doubly Symmetric I-shaped Members Bent About Their Weak Axis
- 5.2.3.6 Singly Symmetric Channels Bent About Their Weak Axis

$E_{L,f}$ = Characteristic longitudinal modulus of the flange, ksi (MPa)

$E_{L,w}$ = Characteristic longitudinal modulus of the web, ksi (MPa)

I_f = Moment of inertia of the flange(s) about the axis of bending, in⁴ (mm⁴)

I_w = Moment of inertia of the web(s) about the axis of bending, in⁴ (mm⁴)

I = Moment of inertia of the member about the axis of bending, in⁴ (mm⁴)

y = Distance from the neutral axis to the extreme fiber of the member, in. (mm)

User Note: For members that have longitudinal elastic moduli in the flanges and webs within 15% of each other $E_{L,f} = E_{L,w} = E_L$ and $E_{T,f} = E_{T,w} = E_T$ in Sections 5.2.3.1 – 5.2.3.6.

5.2.3.1 Singly and Doubly Symmetric I-shaped Members Bent About Their Strong Axis

(a) *Compression flange local buckling*

$$f_{cr} = \frac{4t_f^2}{b_f^2} \left(\frac{7}{12} \sqrt{\frac{E_{L,f} E_{T,f}}{1 + 4.1\xi}} + G_{LT} \right) \quad (5.2.3.1-1)$$

with

$$\xi = \frac{E_{T,f} t_f^3}{b_f k_r 6} \quad (5.2.3.1-2)$$

$$k_r = \frac{E_{T,w} t_w^3}{6h} \left(1 - \left[\left(\frac{48 t_f^2 h^2 E_{L,w}}{11.1 \pi^2 t_w^2 b_f^2 E_{L,f}} \right) \left(\frac{G_{LT}}{1.25 \sqrt{E_{L,w} E_{T,w}} + E_{T,w} \nu_{LT} + 2G_{LT}} \right) \right] \right) \quad (5.2.3.1-3)$$

(b) *Web local buckling*

$$f_{cr} = \frac{11.1 \pi^2 t_w^2}{12 h^2} \left(1.25 \sqrt{E_{L,w} E_{T,w}} + E_{T,w} \nu_{LT} + 2G_{LT} \right) \quad (5.2.3.1-4)$$

5.2.3.2 Singly Symmetric Channels Bent About Their Strong Axis

(a) *Compression flange local buckling*

$$f_{cr} = \frac{t_f^2}{b_f^2} \left(\frac{7}{12} \sqrt{\frac{E_{L,f} E_{T,f}}{1 + 4.1 \xi}} + G_{LT} \right) \quad (5.2.3.2-1)$$

with

$$\xi = \frac{E_{T,f} t_f^3}{b_f k_r 12} \quad (5.2.3.2-2)$$

$$k_r = \frac{E_{T,w} t_w^3}{3h} \left(1 - \left[\left(\frac{48 t_f^2 h^2 E_{L,w}}{11.1 \pi^2 t_w^2 b_f^2 E_{L,f}} \right) \left(\frac{G_{LT}}{1.25 \sqrt{E_{L,w} E_{T,w}} + E_{T,w} \nu_{LT} + 2G_{LT}} \right) \right] \right) \quad (5.2.3.2-3)$$

(b) *Web local buckling*

For web local buckling equation 5.2.3.1-4 shall apply

5.2.3.3 Tees and Back-to-back Angles Bent About Their Strong Axis

(a) *Compression flange local buckling*

For compression flange buckling equation 5.2.3.1-1 shall apply

(b) *Web local buckling*

$$f_{cr} = \frac{4 t_w^2}{h^2} G_{LT} \quad (5.2.3.3-1)$$

5.2.3.4 Square and Rectangular Box Members

(a) *Compression flange local buckling*

$$f_{cr} = \frac{4\pi^2 t_f^2}{b_f^2} \left(\frac{\sqrt{(E_{L,f} E_{T,f})(I + 4.1\xi)}}{6} + \left(2 + 0.62\xi^2 \left(\frac{E_{T,f} \nu_{LT}}{12} + \frac{G_{LT}}{6} \right) \right) \right) \quad (5.2.3.4-1)$$

with

$$\xi = \frac{I}{I + \frac{4E_{T,f} t_f^3}{5k_r b_f}} \quad (5.2.3.4-2)$$

$$k_r = \frac{E_{T,w} t_w^3}{3h} \left(1 - \left[\left(\frac{2t_f^2 h^2 E_{L,f}}{11.1 b_f^2 t_w^2 E_{L,f}} \right) \left(\frac{\sqrt{E_{L,f} E_{T,f}} + E_{T,f} \nu_{LT} + 2G_{LT}}{1.25 \sqrt{E_{L,w} E_{T,w}} + E_{T,w} \nu_{LT} + 2G_{LT}} \right) \right] \right) \quad (5.2.3.4-3)$$

(b) *Web local buckling*

$$f_{cr} = \frac{11.1\pi^2 t_w^2}{6h^2} \left(1.25 \sqrt{E_{L,w} E_{T,w}} + E_{T,w} \nu_{LT} + 2G_{LT} \right) \quad (5.2.3.4-4)$$

5.2.3.5 Doubly Symmetric I-shaped Members Bent About Their Weak Axis

(a) *Compression flange local buckling*

$$f_{cr} = \frac{4t_f^2}{b_f^2} G_{LT} \quad (5.2.3.5-1)$$

5.2.3.6 Singly Symmetric Channels Bent About Their Weak Axis

(a) *Compression flange local buckling*

$$f_{cr} = \frac{t_f^2}{b_f^2} G_{LT} \quad (5.2.3.6-1)$$

(b) *Web local buckling*

$$f_{cr} = \frac{\pi^2 t_w^2}{6h^2} \left(\sqrt{E_{L,w} E_{T,w}} + E_{T,w} \nu_{LT} + 2G_{LT} \right) \quad (5.2.3.6-2)$$

Where

- $E_{L,f}$ = Characteristic longitudinal modulus of the flange, ksi (MPa)
 $E_{L,w}$ = Characteristic longitudinal modulus of the web, ksi (MPa)
 $E_{T,f}$ = Characteristic transverse modulus of the flange, ksi (MPa)
 $E_{T,w}$ = Characteristic transverse modulus of the web, ksi (MPa)
 G_{LT} = Characteristic in-plane shear modulus, ksi (MPa)
 ν_{LT} = Characteristic longitudinal Poisson's ratio (in absence of available data $\nu_{LT} = 0.3$)
 b_f = Full width of the flange, in. (mm)
 h = Full height of the member, in. (mm)
 t_f = Thickness of the flange, in. (mm)
 t_w = Thickness of the web, in. (mm)
 ξ = Coefficient of restraint
 k_r = Rotational spring constant, kip/rad (kN/rad)

5.2.4 Nominal Strength of Members due to Lateral-Torsional Buckling

For failure of the entire section due to global lateral-torsional instability due to compressive stresses, the resistance factor shall be taken as $\phi = 0.70$.

For an I-shaped section bent about its strong axis, the nominal strength due to lateral-torsional buckling shall be determined as,

$$M_n = C_b \sqrt{\frac{\pi^2 E_{L,f} I_y D_J}{L_b^2} + \frac{\pi^4 E_{L,f}^2 I_y C_\omega}{L_b^4}} \quad (5.2.4-1)$$

D_J = Torsional rigidity of an open section = $G_{LT} \sum_i \frac{1}{3} b_i t_i^3$ where the summation extends over all
 "i" the elements of the section, kip-in.² (N-mm²)

C_ω = Warping constant = $\frac{t_f h^2 b_f^3}{24}$, in.⁶ (mm⁶)

For a single-celled doubly symmetric closed rectangular section bent about its strong axis, the nominal strength of members due to lateral-torsional buckling shall be determined as,

$$M_n = C_b \sqrt{\frac{\pi^2 E_{L,f} I_y D_J}{L_b^2}} \quad (5.2.4-2)$$

D_J = Torsional rigidity of a single-celled doubly symmetric thin-walled, closed

$$\text{rectangular section} = 4[(b_f - t_w)(h - t_f)]^2 \left(\frac{G_{LT}}{8} \left(\frac{t_f}{b_f} + \frac{t_w}{h} \right) \right), \text{ kip-in.}^2 \text{ (N-mm}^2\text{)}$$

Where

$E_{L,f}$ = Characteristic longitudinal modulus of the flange, ksi (MPa)

I_y = Moment of inertia about the weak axis of bending, in⁴ (mm⁴)

L_b = Length between points that are either braced against lateral displacement of the compression flange or braced against twist of the cross-section, in. (mm)

C_b = Moment modification factor for unsupported spans with both ends braced (see Section 2.5.5 for bracing requirements)

$$C_b = \frac{12.5M_{\max}}{2.5M_{\max} + 3M_A + 4M_B + 3M_C} \leq 3.0 \quad (5.2.4-3)$$

Where

M_{\max} = Absolute value of maximum moment in the unbraced segment, kip-in. (N-mm)

M_A = Absolute value of moment at quarter point of the unbraced segment, kip-in. (N-mm)

M_B = Absolute value of moment at the centerline of the unbraced segment, kip-in. (N-mm)

M_C = Absolute value of moment at three-quarter point of the unbraced segment, kip-in. (N-mm)

C_b is permitted to be conservatively taken as 1.0 for all cases. For cantilevers or overhangs where the free end is unbraced, $C_b = 1.0$.

For singly symmetric members (i.e, C-shaped or T-shaped members) bent about their strong axis, the lateral-torsional buckling capacity shall be computed based on rational engineering analysis.

5.3 Design of Members for Shear

5.3.1 Design Basis

When subjected to transverse loads that cause the member to bend about the plane of the neutral axis (referred to as the plane of bending), members shall be designed such that

$$V_u \leq \lambda \phi V_n \quad (5.3.1-1)$$

where

V_u = Required shear strength, kip (kN)

ϕ = Resistance factor defined in sections 5.3.2 and 5.3.3

λ = Time effect factor specified in Table 2.3-1

V_n = Nominal shear strength, including reduction factors in Section 2.4, determined in accordance with sections 5.3.2 and 5.3.3, kip (kN)

The factored nominal shear strength of members, ϕV_n shall be taken as the smallest strength obtained from the limit states (a) material rupture in shear and (b) local web buckling.

5.3.2 Nominal Strength of Members due to Material Rupture in Shear

For failure of members due to rupture of the material due to shear stresses, the resistance factor shall be taken as $\phi = 0.65$.

The nominal shear strength of members due to rupture in shear shall be determined as,

$$V_n = F_{LT} A_S \quad (5.3.2-1)$$

where

F_{LT} = Characteristic in-plane shear strength, ksi (MPa)

A_S = Shear Area, in.² (mm²)

5.3.3 Nominal Strength of Members due to Web Shear Buckling

For failure of members due to instability of the webs due to shear stresses, the resistance factor shall be taken as $\phi = 0.80$.

User Note: For members that have longitudinal elastic moduli in the flanges and webs within 15% of each other $E_{L,w} = E_L$ and $E_{T,w} = E_T$ in Section 5.3.3.

For webs of I-members, back-to-back channels, single channels and square and rectangular box members bent about their strong axis, the nominal strength of members due to shear buckling in terms of the properties of the web shall be determined as,

$$V_n = f_{cr} A_S \quad (5.3.3-1)$$

where

f_{cr} = Critical shear buckling stress depending on $2G_{LT} + E_{T,w} \nu_{LT}$ and $\sqrt{E_{L,w} E_{T,w}}$ determined from 5.3.3-2 or 5.3.3-4, ksi (MPa)

A_S = Shear Area, in.² (mm²)

If $2G_{LT} + E_{T,w} \nu_{LT} \leq \sqrt{E_{L,w} E_{T,w}}$

then

$$f_{cr} = \frac{t_w^2 k_{LTl} \sqrt[4]{E_{L,w} (E_{T,w})^3}}{3h^2} \quad (5.3.3-2)$$

where

$$k_{LT_1} = 8.1 + 5.0 \frac{2G_{LT} + E_{T,w}\nu_{LT}}{\sqrt{E_{L,w}E_{T,w}}} \quad (5.3.3-3)$$

If $2G_{LT} + E_{T,w}\nu_{LT} > \sqrt{E_{L,w}E_{T,w}}$

then

$$f_{cr} = \frac{k_{LT_2} E_{T,w} t_w^2}{3h^2} \sqrt{\nu_{LT} + \frac{2G_{LT}}{E_{T,w}}} \quad (5.3.3-4)$$

where

$$k_{LT_2} = 11.7 + 1.4 \left(\frac{\sqrt{E_{L,w}E_{T,w}}}{2G_{LT} + E_{T,w}\nu_{LT}} \right)^2 \quad (5.3.3-5)$$

Where

$E_{L,w}$ = Characteristic longitudinal modulus of the web, ksi (MPa)

$E_{T,w}$ = Characteristic transverse modulus of the web, ksi (MPa)

G_{LT} = Characteristic in-plane shear modulus, ksi (MPa)

ν_{LT} = Characteristic longitudinal Poisson's ratio (in absence of available data $\nu_{LT} = 0.3$)

h = Full height of the member, in. (mm)

$k_{LT_{1,2}}$ = Shear buckling coefficient

For tees, back-to-back angles and members bent about their weak axis, the shear buckling capacity of the elements perpendicular to the plane of bending shall be determined based on rational engineering analysis.

Vertical web stiffeners may be used to increase the resistance of members due to shear buckling of the web. The flexural rigidity, $(EI)_{stiffener}$, of a vertical stiffener about the plane of the vertical element (typically referred to as a "web") shall be proportioned such that

$$(EI)_{stiffener} \geq 0.34 \frac{E_{L,s} d_w^4 t_w^3}{b_s^3} \quad (5.3.3-6)$$

The longitudinal stiffener modulus shall be greater than or equal to the longitudinal modulus of the member (i.e. $E_{L,s} \geq E_L$) and the spacing of the stiffeners must be less than or equal to the depth of the web (i.e. $b_s \leq d_w$).

Stiffeners shall be bolted to the vertical element and extend the full depth of the member from the tension flange to the compression flange.

5.4 Design of Members for Concentrated Forces

5.4.1 Design Basis

At supports and at concentrated force points along the length of the beam, the section shall be designed such that

$$R_u \leq \lambda \phi R_n \quad (5.4.1-1)$$

where

R_u = Required strength of members due to a concentrated force, kip (kN)

ϕ_c = Resistance factor as per sections 5.4.2, 5.4.3, 5.4.4, and 5.4.5

λ = Time effect factor specified in Table 2.3-1

R_n = Nominal strength of members due to a concentrated force, including reduction factors in Section 2.4, determined in accordance with sections 5.4.2, 5.4.3, 5.4.4, and 5.4.5, kip (kN)

The factored nominal strength of members due to concentrated forces, ϕR_n shall be taken as the smallest strength obtained from the limit states of (a) material rupture of the web in tension or compression, (b) web crippling (c) web compression buckling, and (d) flange rupture due to bending.

Bearing stiffeners shall be provided when:

$$R_u > 0.5 \lambda \phi R_n \quad (5.4.1-2)$$

Bearing stiffeners shall be designed according to rational engineering analysis and have a minimum thickness of t_w , and extend from the web to the edge of the flange along the entire depth of the web from the inside of the compression flange to the inside of the tension flange.

5.4.2 Nominal Strength of Members due to Tensile Rupture of Web(s)

For failure of members due to local tensile rupture of the webs of members due to concentrated forces, the resistance factor shall be taken as $\phi = 0.65$.

The nominal strength for tensile material rupture in the web due to a concentrated force shall be determined as,

$$R_n = l_{ten} F_{T,w} t_w \quad (5.4.2-1)$$

where

l_{ten} = Length of web over which the applied tensile force is distributed which is the depth of a members or the spacing between vertical stiffeners on either side of the tensile load, in. (mm)

$F_{T,w}$ = Characteristic transverse strength of the web, ksi (MPa)

t_w = Thickness of the web, in. (mm)

5.4.3 Nominal Strength of Members due to Web Crippling

For failure of members due to local crippling of the webs of members due to concentrated forces, the resistance factor shall be taken as $\phi = 0.70$.

The nominal strength of members at locations of interior supports and concentrated compressive loads for members with depth of $h \leq 12$ inches shall be determined as,

$$R_n = 0.7ht_w F_{sh,int} \left(1 + \frac{2k + 6t_{plate} + b_{plate}}{d_w} \right) \quad (5.4.3-1)$$

where

h = Full height of the member, in. (mm)

t_w = Thickness of the web, in. (mm)

$F_{sh,int}$ = Characteristic interlaminar shear strength of the member, ksi (MPa)

k = Distance from the top of a members to the bottom of the fillet = $t_f + r$, in. (mm)

t_{plate} = Thickness of the bearing plate, in. (mm)

b_{plate} = Length of the bearing plate along the axis of the section, $b_p \leq 4$ inches, in. (mm)

d_w = Depth of the web, in. (mm)

Vertical bearing stiffeners shall be provided directly under the load at all locations of interior supports and concentrated compressive loads for members with depth $h > 12$ inches. At end supports the length of bearing shall be at least $h/2$.

5.4.4 Nominal Strength of Members due to Web Compression Buckling

For failure of members due to local buckling of the webs of members due to concentrated forces in the plane of the web, the resistance factor shall be taken as $\phi = 0.80$.

The nominal strength of members due to web compression buckling is determined as,

$$R_n = f_{cr} A_{eff} \quad (5.4.4-1)$$

where

$$f_{cr} = \frac{\pi^2 t_w^2}{6l_{eff}^2} \left(\sqrt{E_{L,w} E_{T,w} + E_{T,w} \nu_{LT} + 2G_{LT}} \right) \quad (5.4.4-2)$$

A_{eff} = Effective area = $l_{eff} t_w$, in.² (mm²)

l_{eff} = Lesser of the web depth, d_w , and the distance between the vertical web stiffeners, in. (mm)

- t_w = Thickness of the web, in. (mm)
- $E_{L,w}$ = Characteristic longitudinal modulus of the web, ksi (MPa)
- $E_{T,w}$ = Characteristic transverse modulus of the web, ksi (MPa)
- G_{LT} = Characteristic in-plane shear modulus, ksi (MPa)
- ν_{LT} = Characteristic longitudinal Poisson's ratio (in absence of available data $\nu_{LT} = 0.3$)

5.4.5 Nominal Strength of Members due to Flange Flexural Failure

For failure of members due to local flexural failure at the web-flange junction of an outstanding flange due to an eccentric concentrated force (i.e., a load not applied directly over the web), the resistance factor shall be taken as $\phi = 0.65$

The nominal strength of members due to flexural failure of an outstanding flange loaded by an eccentric concentrated force shall be determined as,

$$R_n = \frac{F_{T,f} b t_f^2}{6 l_e} \quad (5.4.5-1)$$

where

- $F_{T,f}$ = Characteristic transverse tensile strength of the flange, ksi (MPa)
- t_f = Thickness of the flange, in. (mm)
- l_e = Distance of concentrated force from the web, in. (mm)
- b = projected width of the concentrated force at the web = $2 l_e$, in. (mm)

5.5 Design for Copes, Notches, Holes and Openings

5.5.1 Copes, Notches, Holes and Openings in the Flange or Web

The effect of all copes, notches, holes and openings on the nominal flexural strength and the nominal shear strength of members shall be determined. When the required strength exceeds the factored nominal strength of members at an unreinforced cope, notch, hole or opening doubler plates shall be used to increase the strength of the section at these locations.

5.5.2 Doubler Plate Requirements

Doubler plates shall be made of pultruded material and bonded using a structural grade adhesive. The adhesive shall cover the entire surface area of the doubler plate and shall be designed to transfer the required force. The shear strength of the adhesive shall be determined according to ASTM D1144. Mechanical fasteners shall be used in addition to the adhesive but their contribution to the strength of the bonded joint shall be neglected.

5.6 Design of Flexural Members for Serviceability

Deflections of flexural members bent about their strong axis shall be determined using the full-section flexural modulus, E_b , and the full-section shear modulus, G_b .

If the full-section flexural modulus is not provided by the manufacturer, it shall be taken as

$$E_b = E_{L,f} \quad (5.6.1-1)$$

If the full-section shear modulus is not provided by the manufacturer, it shall be taken as

$$G_b = G_{LT} \frac{A_w}{A} \quad (5.6.1-2)$$

Where

$E_{L,f}$ = Characteristic longitudinal modulus of the flange, ksi (MPa)

G_{LT} = Characteristic in-plane shear modulus, ksi (MPa)

A = Gross area of the cross section, in.² (mm²)

A_w = Area of all webs = $\sum_i d_{w,i} t_{w,i}$, in.² (mm²)

6. DESIGN OF MEMBERS UNDER COMBINED FORCES & TORSION

This chapter provides provisions for design of members under combined forces and torsion. It is organized as follows:

- 6.1 Scope
- 6.2 Doubly and Singly Symmetric Members Subject to Flexure and Axial Force
- 6.3 Doubly Symmetric Members under Torsion and Combined Torsion, Flexure and/or Axial Force

6.1 Scope

The design provisions of this chapter apply to both singly and doubly symmetric pultruded FRP shapes subjected to axial force and flexure about one or both axes of symmetry with or without torsion, and torsion only. If transverse loads on a member do not pass through the center of gravity of the structural shape, the member must be designed for the resulting torsion as well. The design equations apply only to members with symmetric glass reinforcement.

6.2 Doubly and Singly Symmetric Members Subject to Flexure and Axial Force

6.2.1 Doubly and Singly Symmetric Members Subject to Flexure and Compression

The interaction of flexure and compression in doubly and singly symmetric members shall be governed by Equation (6.2-1)

$$\frac{P_u}{P_c} + \frac{M_{ux}}{M_{cx}} + \frac{M_{uy}}{M_{cy}} \leq 1.0 \quad (6.2-1)$$

where,

P_u = required axial compression strength due to factored loads

$P_c = \lambda \phi_c P_n$ = available axial compressive strength

P_n = characteristic value of axial force as modified by the requirement of Section 2.4

M_u = required flexural strength due to factored loads

$M_c = \lambda \phi_b M_n$ = available flexural strength

M_n = characteristic value of flexural strength as modified by the requirement of Section 2.4

x = subscript referring to strong axis bending

y = subscript referring to weak axis bending

ϕ_c = resistance factor ϕ is 0.7 for compression rupture and global buckling and 0.8 for local buckling

ϕ_b = resistance factor ϕ is 0.7 for lateral torsional buckling and web crippling, and 0.8 for local instability and web compression buckling

λ = time effect factor defined in Table 2.3-1

6.2.2 Doubly and Singly Symmetric Members Subject to Flexure and Tension

The interaction of flexure and tension in doubly and singly symmetric members shall be governed by Equation (6.2-2)

$$\frac{P_u}{P_c} + \frac{M_{ux}}{M_{cx}} + \frac{M_{uy}}{M_{cy}} \leq 1.0 \quad (6.2-2)$$

where,

P_u = required axial tensile strength due to factored loads

$P_c = \lambda\phi_t P_n$ = available axial tensile strength

P_n = characteristic value of axial force as modified by the requirement of Section 2.4

M_u = required flexural strength due to factored loads

$M_c = \lambda\phi_b M_n$ = available flexural strength

M_n = characteristic value of flexural strength as modified by the requirement of Section 2.4

x = subscript referring to strong axis bending

y = subscript referring to weak axis bending

ϕ_t = resistance factor ϕ is 0.65 for tension

ϕ_b = resistance factor ϕ is 0.7 for lateral torsional buckling and web crippling, and 0.8 for local instability and web compression buckling

λ = time effect factor defined in Table 2.3-1

6.2.3 Doubly and Singly Symmetric Members Subject to Only Strong Axis Flexure and Compression

The interaction of flexure and compression in doubly and singly symmetric members shall be governed by Equation (6.2-3)

$$\frac{P_u}{P_c} + \frac{M_{ux}}{M_{cx}} \leq 1.0 \quad (6.2-3)$$

where,

P_u = required axial compression strength due to factored loads

$P_c = \lambda\phi_c P_n$ = available axial compressive strength

P_n = characteristic value of axial force as modified by the requirement of Section 2.4

P_e = elastic Euler buckling load in accordance with Chapter 4

M_u = required flexural strength due to factored loads

$M_c = \lambda\phi_b M_n$ = available flexural strength

M_n = characteristic value of flexural strength as modified by the requirement of Section 2.4

x = subscript referring to strong axis bending

ϕ_c = resistance factor ϕ is 0.7 for compression rupture and global buckling and 0.8 for local buckling

ϕ_b = resistance factor ϕ is 0.7 for lateral torsional buckling and web crippling, and 0.8 for local instability and web compression buckling

λ = time effect factor defined in Table 2.3-1

6.2.4 Doubly and Singly Symmetric Members Subject to Only Strong Axis Flexure and Tension

The interaction of flexure and tension in doubly and singly symmetric members shall be governed by Equation (6.2-4)

$$\frac{P_u}{P_c} + \frac{M_{ux}}{M_{cx}} \leq 1.0 \quad (6.2-4)$$

where,

P_u = required axial tensile strength due to factored loads

$P_c = \lambda \phi_t P_n$ = available axial tensile strength

P_n = characteristic value of axial force as modified by the requirement of Section 2.4

M_u = required flexural strength due to factored loads

$M_c = \lambda \phi_b M_n$ = available flexural strength

M_n = characteristic value of flexural strength as modified by the requirement of Section 2.4

x = subscript referring to strong axis bending

ϕ_t = resistance factor ϕ is 0.65 for tension

ϕ_b = resistance factor ϕ is 0.7 for lateral torsional buckling and web crippling, and 0.8 for local instability and web compression buckling

λ = time effect factor defined in Table 2.3-1

6.3 Doubly Symmetric Members under Torsion and Combined Torsion, Flexure, and/or Axial Force

6.3.1 Torsional Strength of Circular and Rectangular Hollow Tubes

A member under torsional buckling and torsional rupture shall satisfy the following equation:

$$T_u \leq \lambda \phi T_n = T_c \quad (6.3-1)$$

where,

T_u = required torsional strength due to factored loads

T_n = characteristic value of torsional strength (equations 6.3-2a or b) as modified by the requirements of Section 2.4

λ = time effect factor defined in Section 2.3.1 in Table 2.3-2

ϕ = resistance factor ϕ is 0.7 for torsion

T_c = available torsional design strength

The nominal torsional strength T_n of hollow tubes according to the limit states of torsional rupture and torsional buckling shall be limited by Equation (6.3-2)

When strength governs:

$$T_n = F_n \hat{J} \quad (6.3-2a)$$

When stiffness (buckling) governs:

$$T_n = F_{cr} C \quad (6.3-2b)$$

where,

$$F_n = \gamma G_{LT}$$

γ = nominal coupon specimen shear strain/unit length from the characteristic value of coupon, as defined in ASTM D5379-05

G_{LT} = nominal in-plane shear modulus of elasticity from the characteristic value of coupon, as defined in ASTM D5379-05

\hat{J} = St Venant torsion constant for circular tubes, rectangular tubes and wide flange beams as defined in Equations 6.3-3, 6.3-4 and 6.3-5, in⁴ (mm⁴)

C = torsional constant for circular tubes, rectangular tubes and wide flange beams as defined in Equations 6.3-6, 6.3-7 and 6.3-8, in³ (mm³)

For a circular tube, the St Venant torsion constant \hat{J} (polar moment of inertia) shall be taken as:

$$\hat{J} = \pi/2 (R^4 - R_i^4) \quad (6.3-3)$$

For a rectangular tube, the St Venant torsion constant \hat{J} shall be taken as:

$$\hat{J} = 2 A^2 / (d_w/t_w + b_f/t_f) \quad (6.3-4)$$

For a wide flange beam, the St Venant torsion constant \hat{J} shall be taken as:

$$\hat{J} = (2 b_f t_f^3 + d_w t_w^3) / 3 \quad (6.3-5)$$

For a circular tube, the torsional constant C shall be taken as:

$$C = \frac{\pi t (2R - t)^2}{2} \quad (6.3-6)$$

For a rectangular tube, the torsional constant C shall be taken as:

$$C = 2t(b_r - t)(h - t) \quad (6.3-7)$$

For a wide flange beam, the torsional constant C shall be taken as:

$$C = \hat{J} / t_f \quad (6.3-8)$$

where,

A = mean of the areas enclosed by the inner and outer boundaries
 b_f = outer width of rectangular tube section
 b_f = width of the flange between the centers of webs in rectangular tubes, and flange width for T-, I-, and C- beams
 d_w = the clear depth of the web
 h = depth of rectangular tube section
 R = outer radius of a circular tube
 t = thickness of an element in the cross section
 t_f = thickness of the flange
 t_w = thickness of the web

When stiffness governs, F_{cr} shall be determined as follows for circular hollow tubes. F_{cr} is the lowest of Equation 6.3-9 or 6.3-10:

$$F_{cr} = \frac{0.236(E_T^c)^{5/8}(E_L^c)^{3/8}}{\left(\frac{R}{t}\right)^{3/2}} \leq F_{LT}^v \quad (6.3-9)$$

$$F_{cr} = \frac{0.733(E_T^c)^{5/8}(E_L^c)^{3/8}}{\left(\frac{R}{t}\right)^{5/4} \sqrt{\frac{L}{R}}} \leq F_{LT}^v \quad (6.3-10)$$

The critical torsional buckling stress F_{cr} shall **NOT** exceed the in-plane shear strength F_{LT}^v

where,

E_L^c = longitudinal compression modulus
 E_T^c = transverse compression modulus
 R = circular tube outer radius
 t = tube thickness

F_{cr} shall be determined as follows for rectangular hollow tubes, where stiffness governs:

$$F_{cr} = \frac{G_{LT} b_f d_w (d_w + b_f) t}{2I_o} \quad (6.3-11)$$

F_{cr} shall be determined as follows for wide flange beams where stiffness governs:

$$F_{cr} = \frac{G_{LT}}{3I_o} (2b_f t_f^3 + d_w t_w^3) + \frac{E_L^c}{24I_o} \left(\frac{\pi}{l_b} \right)^2 (t_f b_f^3 d_w^2) \quad (6.3-12)$$

Where,

I_o = sum of moments of inertia about the strong axis of bending and the weak axis of bending

l_b = lengths between points that are braced against twist of the cross section

G_{LT} = in-plane shear modulus, ksi (Mpa)

6.3.2 Rectangular Hollow Tubes Subject to Combined Torsion, Flexure and Axial Force

The interaction of torsion, flexure and axial force shall be limited by Equation (6.3-13)

$$\frac{P_u}{P_c} + \frac{M_u}{M_c} + \left(\frac{T_u}{T_c} \right)^2 \leq 1.0 \quad (6.3-13)$$

Where,

P_u = required axial tensile or compressive strength due to factored loads

$P_c = \lambda \phi_{t,c} P_n$ = available axial tensile or compressive strength

P_n = characteristic value of axial force as modified by the requirement of Section 2.4

M_u = required flexural strength due to factored loads; second order effects must be included if necessary

$M_c = \lambda \phi_b M_n$ = available flexural strength

M_n = characteristic value of flexural strength as modified by the requirement of Section 2.4

T_u = required torsional strength due to factored loads

$T_c = \lambda \phi_T T_n$ = available torsional design strength

T_n = characteristic value of torsional strength (equations 6.3-2a or b) as modified by the requirements of Section 2.4 ϕ_t = resistance factor ϕ is 0.65 for tension

ϕ_c = resistance factor ϕ is 0.7 for compression rupture and global buckling and 0.8 for local buckling

ϕ_b = resistance factor ϕ is 0.7 for lateral torsional buckling and web crippling, and 0.8 for local instability and web compression buckling

ϕ_T = resistance factor ϕ is 0.7 for torsion

λ = time effect factor defined in Table 2.3-1

6.3.3 Design Strength of Open Doubly Symmetric Shapes Subject to Torsion and Combined Forces

All stresses shall be determined using linear elastic analysis. For open cross sections where stresses occur simultaneously, interaction equation 6.3-13 shall be used as a design criterion.

7. DESIGN OF PLATES AND BUILT-UP MEMBERS

This chapter provides design provisions for rectangular plates and built-up members subjected to loads applied normal and parallel to the planar surface.

The chapter is organized as follows:

- 7.1 Scope
- 7.2 General Provisions
- 7.3 Design of Plates Subjected to Flexure
- 7.4 Design of Plates Subjected to Through-the-Thickness Shear
- 7.5 Design of Plates Subjected to In-Plane Tensile Loading
- 7.6 Design of Plates Subjected to In-Plane Compressive Loading
- 7.7 Design of Plates Subjected to In-Plane Shear Loading
- 7.8 Design of Built-up Members
- 7.9 Design of Decking Members
- 7.10 Design of Plates for Serviceability

7.1 Scope

The design provisions of this chapter apply to pultruded FRP structural shapes configured as flat plates and built-up members using flat plates subjected to flexure, through-the-thickness shear and in-plane loading and comply with the requirements specified in Section 7.2 General Provisions.

7.2 General Provisions

A pultruded plate is a planar load carrying member spanning two directions, the thickness of which is significantly less than its side lengths. The material longitudinal direction (pultrusion direction) is the direction of the continuous strand rovings. The material transverse direction is the direction perpendicular to the pultrusion direction.

The provisions in this Chapter are limited to rectangular plates and built-up members whose side lengths in the material longitudinal and transverse directions are greater than or equal to 20 times the plate thickness.

$$\begin{aligned} a &\geq 20t \\ b &\geq 20t \end{aligned} \tag{7.2-1}$$

where

- t = Thickness of the plate
- a = Span length of the plate in the material longitudinal direction
- b = Span length of the plate in the material transverse direction

The principal material directions shall be parallel to the sides (edges) of the rectangular plate. The elastic modulus and the flexural strength in the material transverse direction shall equal or exceed

$$E_T \geq \frac{1}{3} E_L \tag{7.2-2}$$

$$F_T^f \geq \frac{1}{3} F_L^f \tag{7.2-3}$$

where

E_L = Characteristic longitudinal elastic modulus
 E_T = Characteristic transverse elastic modulus
 F_L^f = Characteristic longitudinal flexural strength
 F_T^f = Characteristic transverse flexural strength

The design strength shall be obtained based on the nominal strength, R_n , adjusted as appropriate for end-use conditions in accordance with Section 2.4. The section shall be designed such that

$$R_u \leq \lambda \phi R_n \quad (7.2-4)$$

where

R_u = Required strength
 ϕ = Resistance factor
 λ = Time effect factor specified in Table 2.3-1
 R_n = Nominal strength

7.3 Design of Plates Subjected to Flexure

7.3.1 Nominal Flexural Strength of Plates for One-Way Plate Bending

These provisions for one-way plate bending are limited to: (a) bending along a principal material direction for plates supported only on two opposite edges perpendicular to the bending direction, and (b) bending along the shorter span length (minimum of span lengths a and b) for plates supported on three or four edges, which do not satisfy the requirements set forth in Section 7.3.2.

The nominal flexural strength, M_n , shall be obtained according to the limit state of material rupture. The section shall be designed such that

$$M_u \leq \lambda \phi_f M_n \quad (7.3.1-1)$$

where

M_u = Required flexural strength per unit length
 ϕ_f = 0.70
 M_n = Nominal flexural strength per unit length

The nominal flexural strength in the material longitudinal direction shall be determined from,

$$M_n = F_L^f \frac{t^2}{6} \quad (7.3.1-2)$$

where

F_L^f = Characteristic longitudinal flexural strength

The nominal flexural strength in the material transverse direction shall be determined from,

$$M_n = F_T^f \frac{t^2}{6} \quad (7.3.1-3)$$

where

F_T^f = Characteristic transverse flexural strength

7.3.2 Nominal Flexural Strength of Plates for Two-Way Plate Bending

These provisions for two-way plate bending are limited to plates supported on three or four edges. The geometric aspect ratio (a/b) of pultruded plates for two-way plate bending shall be limited by

$$\frac{1}{2} \sqrt{\frac{E_L}{E_T}} \leq \frac{a}{b} \leq 2 \sqrt{\frac{E_L}{E_T}} \quad (7.3.2-1)$$

where

a = Span length of the plate in the material longitudinal direction

b = Span length of the plate in the material transverse direction

E_L = Characteristic longitudinal elastic modulus

E_T = Characteristic transverse elastic modulus

The nominal flexural strength, M_n , shall be obtained for the limit states of (a) material rupture for bending in the material longitudinal direction, and (b) material rupture for bending in the material transverse direction. The section shall be designed for each of the two principal material directions such that

$$M_u \leq \lambda \phi_f M_n \quad (7.3.2-2)$$

where

M_u = Required flexural strength per unit length

ϕ_f = 0.70

M_n = Nominal flexural strength per unit length determined in accordance with Section 7.3.1

7.4 Design of Plates Subjected to Through-the-Thickness Shear

7.4.1 Nominal Shear Strength of Plates for One-Way Plate Bending

The nominal shear strength, V_n , shall be obtained according to the limit state of material rupture in shear. The section shall be designed such that

$$V_u \leq \lambda \phi_v V_n \quad (7.4.1-1)$$

where

V_u = Required shear strength per unit length

ϕ_v = 0.70

V_n = Nominal shear strength per unit length

The nominal shear strength, V_n , due to rupture in shear in the material longitudinal direction shall be determined from,

$$V_n = F_L^v t \quad (7.4.1-2)$$

where

F_L^v = Characteristic through-the-thickness shear strength on a plane perpendicular to the material longitudinal direction

The nominal shear strength, V_n , due to rupture in shear in the material transverse direction shall be determined from,

$$V_n = F_T^v t \quad (7.4.1-3)$$

where

F_T^v = Characteristic through-the-thickness shear strength on a plane perpendicular to the material transverse direction

7.4.2 Nominal Shear Strength of Plates for Two-Way Plate Bending

The nominal shear strength, V_n , shall be obtained for the limit states of (a) material rupture in shear on a plane perpendicular to the material longitudinal direction, and (b) material rupture in shear on a plane perpendicular to the material transverse direction. The section shall be designed for each of the two principal material directions such that

$$V_u \leq \lambda \phi_v V_n \quad (7.4.2-1)$$

where

V_u = Required shear strength per unit length

ϕ_v = 0.70

V_n = Nominal shear strength per unit length determined in accordance with Section 7.4.1

7.4.3 Pull-Through Strength of Plates

Pull-through strength is defined as the maximum load that a pultruded plate mechanically fastened to another pultruded component can sustain, when the component is pulled apart perpendicular to the plane of the plate. Pull-through failure is defined as the separation of the fastener and the plate, caused by failure of the fastener, the pultruded plate or both.

The nominal pull-through strength per fastener, R_n^t , shall be obtained according to the limit state of material rupture due to out-of-plane loading. The section shall be designed such that

$$R_u^t \leq \lambda \phi_v R_n^t \quad (7.4.3-1)$$

where

R_u^t = Required pull-through strength per fastener

ϕ_v = 0.70

R_n^t = Nominal pull-through strength per fastener

The nominal pull-through strength per fastener, R_n^t , shall be determined from,

$$R_n^t = F^t \quad (7.4.3-2)$$

where

F^t = Characteristic pull-through strength per fastener

7.5 Design of Plates Subjected to In-Plane Tensile Loading

7.5.1 Nominal Tensile Strength of Plates

The nominal tensile strength of plates, N_n^t , shall be obtained according to the limit state of material rupture in tension due to in-plane edge loads. The section shall be designed such that

$$N_u^t \leq \lambda \phi_t N_n^t \quad (7.5.1-1)$$

where

N_u^t = Required tensile strength per unit length

ϕ_t = 0.65

N_n^t = Nominal tensile strength per unit length determined in accordance with Sections 7.5.2 and 7.5.3

The nominal tensile strength of pultruded plates shall comply with the requirements set forth in Section 3.2. In the presence of a hole or other discontinuity, the nominal tensile strength of pultruded plates shall be multiplied by the open-hole (notched) strength reduction factor. The open-hole strength reduction factor is defined as the ratio between the nominal open-hole net-section tensile strength and the nominal tensile strength.

7.5.2 Nominal Strength of Plates Subjected to Longitudinal Tension

The nominal tensile strength, N_n^t , shall be determined from,

$$N_n^t = k_L^{-1} F_L^t A_e \quad (7.5.2-1)$$

in which

$$k_L^{-1} = \frac{F_L^m}{F_L^t} = 0.7 \quad (7.5.2-2)$$

where

A_e = Effective net area of plate subjected to tension per unit length, defined in Section 2.10.3

k_L^{-1} = Open-hole (notched) longitudinal strength reduction factor

F_L^t = Characteristic longitudinal tensile strength

F_L^m = Characteristic open-hole net-section longitudinal tensile strength

7.5.3 Nominal Strength of Plates Subjected to Transverse Tension

The nominal tensile strength, N_n^t , shall be determined from,

$$N_n^t = k_T^{-1} F_T^t A_e \quad (7.5.3-1)$$

in which

$$k_T^{-1} = \frac{F_T^m}{F_T^t} = 0.85 \quad (7.5.3-2)$$

where

k_T^{-1} = Open-hole (notched) transverse strength reduction factor

F_T^t = Characteristic transverse tensile strength

F_T^m = Characteristic open-hole net-section transverse tensile strength

7.6 Design of Plates Subjected to In-Plane Compressive Loading

7.6.1 Nominal Compressive Strength of Plates

The nominal compressive strength, N_n^c , shall be the lower value obtained according to the limit states of (a) material rupture in compression, and (b) plate buckling due to in-plane compressive edge loads. The section shall be designed such that

$$N_u^c \leq \lambda \phi_c N_n^c \quad (7.6.1-1)$$

where

N_u^c = Required compressive strength per unit length

ϕ_c = 0.70

N_n^c = Nominal compressive strength per unit length determined in accordance with Equations (7.6.2-1), (7.6.2-2), (7.6.3-1) and (7.6.4-1)

The deviation of the pultruded plate surface from flat along the span length (flatness) shall not exceed 0.1 inches times the length in feet (8.3 mm times the length in meters). The deviation of the pultruded plate sides from a straight line shall not exceed 0.025 inches times the side length in feet (2.1 mm times the side length in meters).

7.6.2 Nominal Material Rupture Strength of Plates Subjected to Compression

The nominal in-plane longitudinal compressive strength, $N_{L,n}^c$, shall be determined from,

$$N_{L,n}^c = F_L^c t \quad (7.6.2-1)$$

The nominal in-plane transverse compressive strength, $N_{T,n}^c$, shall be determined from,

$$N_{T,n}^c = F_T^c t \quad (7.6.2-2)$$

where

t = Thickness of the plate

F_L^c = Characteristic longitudinal compressive strength

F_T^c = Characteristic transverse compressive strength

7.6.3 Nominal Strength of Plates Subjected to Longitudinal Compression

The nominal buckling strength of a rectangular plate supported around the edges shall be determined from,

$$N_{L,n}^c = F_L^{cr} t \quad (7.6.3-1)$$

in which

$$F_L^{cr} = \left(\frac{t}{b}\right)^2 \frac{\pi^2}{6} \left((4k_{cr} - 3) \sqrt{E_L E_T} + k_{cr} E_T \nu_{LT} + 2k_{cr} G_{LT} \right) \quad (7.6.3-2)$$

where

F_L^{cr} = Longitudinal elastic buckling stress

b = Span length of the plate in the material transverse direction

k_{cr} = Edge rotation partial restraint coefficient

E_L = Characteristic longitudinal elastic modulus

E_T = Characteristic transverse elastic modulus

G_{LT} = Characteristic in-plane shear modulus

ν_{LT} = Characteristic value of Poisson's ratio associated with transverse deformation when stress is applied in the material longitudinal direction

The plate edge rotation partial restraint coefficient shall be limited by

$$1.0 \leq k_{cr} \leq 1.3 \quad (7.6.3-3)$$

in which $k_{cr} = 1.0$ corresponds to simple supports, and $k_{cr} = 1.3$ corresponds to fixed supports around the edges. If the rectangular plate rotation is partially restrained around the edges, then $k_{cr} = 1.0$ provides a conservative estimate of the nominal buckling strength.

7.6.4 Nominal Strength of Plates Subjected to Combined Longitudinal and Transverse Compression

The nominal buckling strength of a rectangular plate simply supported around the edges subjected to combined longitudinal and transverse compression shall be determined from,

$$N_{L,n}^c = F_L^{cr} t \quad (7.6.4-1)$$

in which

$$F_L^{cr} = \left(\frac{t}{b}\right)^2 \frac{\pi^2}{12} \left(\frac{E_L \left(\frac{b}{a}\right)^4 + 2(E_T \nu_{LT} + 2G_{LT}) \left(\frac{b}{a}\right)^2 + E_T}{\left(\frac{b}{a}\right)^2 + \xi_{LT}} \right) \quad (7.6.4-2)$$

where

ξ_{LT} = Ratio of applied transverse to longitudinal compressive loading

The ratio of applied transverse to longitudinal compressive loading shall be limited by

$$0.3 \leq \xi_{LT} \leq 1.0 \quad (7.6.4-3)$$

7.7 Design of Plates Subjected to In-Plane Shear Loading

7.7.1 Nominal In-Plane Shear Strength of Plates

The nominal in-plane shear strength, $N_{LT,n}$, shall be the lower value obtained according to the limit states of (a) material rupture in in-plane shear, and (b) plate buckling due to in-plane edge shear loads. The section shall be designed such that

$$N_{LT,u} \leq \lambda \phi_v N_{LT,n} \quad (7.7.1-1)$$

where

$N_{LT,u}$ = Required in-plane shear strength per unit length

ϕ_v = 0.70

$N_{LT,n}$ = Nominal in-plane shear strength per unit length determined in accordance with Equations (7.7.2-1) and (7.7.3-1)

7.7.2 Nominal Material Rupture Strength of Plates Subjected to In-Plane Shear

The nominal in-plane shear strength, $N_{LT,n}$, shall be determined from,

$$N_{LT,n} = F_{LT} t \quad (7.7.2-1)$$

where

t = Thickness of the plate

F_{LT} = Characteristic in-plane shear strength

7.7.3 Nominal Buckling Strength of Plates Subjected to In-Plane Shear

The nominal in-plane shear strength, $N_{LT,n}$, of a rectangular plate simply supported around the edges shall be determined from,

$$N_{LT,n} = F_{LT}^{cr} t \quad (7.7.3-1)$$

in which

$$F_{LT}^{cr} = \begin{cases} \frac{1}{3} (8.1 + 5.0 \eta_{LT}) \left(\frac{t}{b} \right)^2 \sqrt[4]{E_L E_T^3} & 0 < \eta_{LT} \leq 1 \\ \frac{1}{3} \left(11.7 + \frac{1.4}{\eta_{LT}^2} \right) \left(\frac{t}{b} \right)^2 \sqrt{E_T (E_T \nu_{LT} + 2G_{LT})} & \eta_{LT} > 1 \end{cases} \quad (7.7.3-2)$$

in which

$$\eta_{LT} = \frac{2G_{LT} + E_T \nu_{LT}}{\sqrt{E_L E_T}} \quad (7.7.3-3)$$

where

b = Span length of the plate in the material transverse direction

η_{LT} = Elastic parameter

E_L = Characteristic longitudinal elastic modulus

E_T = Characteristic transverse elastic modulus

G_{LT} = Characteristic in-plane shear modulus

ν_{LT} = Characteristic value of Poisson's ratio associated with transverse deformation when stress is applied in the material longitudinal direction

7.8 Design of Built-up Members

7.8.1 Design Basis

Built-up members include panel-based assemblies, plate girders, shear walls and diaphragms consisting of two or more pultruded components connected together. Built-up members shall be assembled from rectangular pultruded plates and pultruded sections with principal material directions parallel or perpendicular to the edges of the structural system. Built-up members shall be connected so that the assembly acts as a unit with forces distributed in proportion to component stiffnesses.

Testing of built-up members shall be conducted according to the requirements of Section 1.7.3 (b) whenever adequate supporting data for design is not available or full composite action is not guaranteed. The strength of built-up members assembled from connected components shall be determined using a transformed section analysis unless a different value is substantiated by testing. Where the composition or configuration of built-up members is such that compliance with the provisions of this Standard cannot be determined by analysis, it is permitted to establish such compliance on the basis of test results that are evaluated in accordance with Section 2.3.2.

Built-up members shall be connected by fasteners in compliance with the requirements for bolted connections set forth in Section 8.2 unless qualification tests show that a higher strength can be substantiated by structural grade adhesives. Adhesives used for bonding components shall be specified by the designer for time factor and for the sustained end-use conditions and shall conform to applicable adhesive specifications. The finite deformation of the fasteners in developing composite action shall be taken into account; otherwise, the strength of built-up members shall be limited to the sum of the strengths of the individual components.

The strength of connections with up to three fasteners in a line and/or with up to three rows of fasteners either normal or parallel to the direction of the connection force shall be determined in compliance with the pertinent provisions of Section 8.3. Connections with more than three fasteners per row shall be designed as a number of individual fasteners in compliance with the pertinent provisions of Section 8.3. When built-up members are made of elements that are end joined with mechanical fasteners or mechanical fasteners and adhesive, the required material properties of the composite member shall be determined in accordance with the requirements of Section 1.7.3 (b).

7.8.2 Design of Built-up Members Subjected to In-Plane Tensile Loading

The built-up member tensile strength shall be determined by summing the forces acting in the components at the axial deformation at which the first component reaches its individual strength. The connections shall be adequate to insure a distribution of the axial tension among the individual components in proportion to their axial stiffnesses. The effects of splices on reducing the member strength shall be accounted for in the design.

7.8.3 Design of Built-up Members Subjected to In-Plane Compressive Loading

The built-up member compressive strength shall be determined by summing the forces acting in the components at the axial deformation at which the first component reaches its individual buckling strength unless qualification tests show that a higher strength can be substantiated. The connections shall be adequate to insure a distribution the axial compression among the individual components in proportion to their axial stiffnesses.

7.8.4 Design of Built-up Members Subjected to Through-the-Thickness Shear

The built-up member through-the-thickness shear strength shall be determined by summing the forces acting in the web components at the shear deformation at which the first component reaches its individual strength. The connections shall be adequate to ensure a distribution of the horizontal shear forces among the individual web components in proportion to their stiffnesses. The nominal shear strength of the built-up member shall be determined in accordance with the provisions in Section 5.3.2.

7.8.5 Design of Panel-Based Assemblies

Panel-based assemblies include light-frame floors, walls, and roofs, and other structural configurations with parallel pultruded web components joined by a pultruded plate.

The provisions of this section shall be used to determine the flexural strength of panel-based assemblies unless a complete structural analysis including load sharing and partial composite action is conducted or the benefits of assembly effects are neglected.

If a structural analysis based on load sharing is used, the loads in the analysis shall be distributed to each member in proportion to the member's stiffness relative to the stiffness of the entire assembly. For design purposes, a panel-based assembly is treated as a single member subsystem composed of pultruded plates and web components.

The scope of the panel-based assemblies is limited to components that are connected together to develop composite action. The provisions in Section 7.8.6 are limited to pre-engineered panel-based assemblies manufactured in plants.

The design procedure for panel-based assemblies shall consist of evaluating a series of equations representing potential failure modes and serviceability limit states for the particular assembly. The design of panel-based assemblies shall consider the following limit states:

Strength limit states:

- a) Panel flexural strength caused by either top or bottom plate limitations (tension or compression),
- b) Plate buckling in the direction parallel to the stringers,
- c) Panel flexural strength caused by stringers limitations (tension or compression),
- d) Panel flexural strength in the direction perpendicular to the stringers caused by plate bending,
- e) Through-the-thickness shear strength of the plate at the plate-stringer interfaces,
- f) Shear strength of stringers web,
- g) Shear transfer strength through fasteners between the plate and the stringers,
- h) Strength of splice plates (if applicable) for transferring stresses,
- i) Notched tensile strength of plates (if applicable),
- j) Pull-through strength of the plate per fastener (if applicable), and
- k) Combined bending and axial strength if the panel-based assembly is used under combined loading (e.g., as a wall panel).

The nominal flexural strength of web components shall comply with the requirements set forth in Section 5.2. Panel-based assemblies shall be connected by fasteners in compliance with the requirements for bolted connections set forth in Section 8.2 unless qualification tests show that a higher strength can be substantiated by structural grade adhesives.

Service limit states:

- a) Flexural deflection of panel
- b) Shear deflection of panel (if applicable)
- c) Combined flexural and shear deflection (if applicable); and
- d) Top and bottom plate deflections between webs.

7.8.5.1 Nominal Flexural Strength of Panel-Based Assemblies for One-Way Plate Bending

The provisions for one-way plate bending shall be limited to rectangular plates with attached equidistant web components parallel to one of the plate principal material directions and supported only on two opposite edges perpendicular to the direction of the web components.

The nominal flexural strength, M_n , shall be the lowest value obtained according to the limit states of (a) material rupture in tension due to bending in the direction of the webs, (b) material rupture in compression due to bending in the direction of the webs, and (c) material rupture in flexure of the plates in the direction perpendicular to the webs. The section shall be designed such that

$$M_u \leq \lambda \phi_f M_n \quad (7.8.5.1-1)$$

where

M_u = Required flexural strength per unit length

ϕ_f = 0.70

M_n = Nominal flexural strength per unit length

The nominal flexural strength due to tensile material failure and compressive material failure of the plate and the web components section shall be determined in accordance with the provisions in Section 5.2.2.

The nominal flexural strength of the plate section shall be determined in accordance with the provisions in Section 7.3.1.

7.8.5.2 Nominal Flexural Strength of Panel-Based Assemblies for Two-Way Plate Bending

The provisions for two-way plate bending shall be limited to built-up members consisting of top and bottom rectangular plates (face sheets) with interior equidistant web components parallel to one of the plate principal material directions, and supported on three or four edges.

The nominal flexural strength, M_n , shall be obtained for the limit states of (a) material rupture in tension due to bending in the direction of the webs, (b) material rupture in compression due to bending in the direction of the webs, (c) material rupture in tension due to bending in the direction perpendicular to the webs, and (d) material rupture in compression due to bending in the direction perpendicular to the webs.

The section shall be designed for each of the two principal material directions (parallel and perpendicular to the webs) such that

$$M_u \leq \lambda \phi_f M_n \quad (7.8.5.2-1)$$

where

M_u = Required flexural strength per unit length

ϕ_f = 0.70

M_n = Nominal flexural strength per unit length

The nominal flexural strength due to tensile material failure and compressive material failure of the plate and the web components shall be determined in accordance with the provisions in Section 5.2.2. The nominal flexural strength of the plate section shall be determined in accordance with the provisions in Section 7.3.1.

7.8.6 Design of Plate Girders

Plate girders include open and closed built-up beam sections. The provisions of this section shall be used to determine the strength of plate girders unless qualification tests show that a higher strength can be substantiated. Such plate girders include built-up beams and columns, and other structural configurations with pultruded plates acting as webs connected to pultruded flange components.

For design purposes, a plate girder is treated as a single member subsystem composed of pultruded plates and flange components. The scope of plate girders is limited to components that are connected together to develop composite action. The provisions in Section 7.8.7 are limited to plate girders manufactured in plants. Such assemblies shall be subject to an ongoing quality control program.

The design of panel-based assemblies shall take the following limit states into account:

Strength limit states:

- a) In-plane shear strength of plate webs,
- b) Shear transfer at web splices,
- c) Flexural strength of web splices,
- d) Shear transfer strength between web and flange components,
- e) Pull-through strength of mechanically fastened plates,
- f) Flexural strength of the built-up beam,
- g) Tension and compression strength of the appropriate flange components,
- h) Notched tensile strength of plates,
- i) Bearing strength of flange components under the stiffeners,
- j) Through-the-thickness shear strength of web plates at the stiffeners interface, and
- k) Lateral stability of the built-up beam.

Service limit states:

- a) Deflection caused by flexure,
- b) Deflection caused by shear, and
- c) Combined flexural and shear deflection.

The nominal flexural strength of built-up beams shall comply with the requirements set forth in Section 5.2. Plate girder components shall be connected by fasteners in compliance with the requirements for bolted connections set forth in Section 8.2 unless qualification tests show that a higher strength can be substantiated by structural grade adhesives.

7.8.7 Design of Shear Walls and Diaphragms

Design provisions of this section apply to sheathed shear walls (vertical diaphragms) and horizontal diaphragms made with connected pultruded plates and framing components acting as elements of the lateral force-resisting system.

The nominal diaphragm strength, D_n , shall be the lowest value obtained according to the limit states of (a) material rupture of the plate in in-plane shear, (b) plate buckling due to in-plane edge shear loads, and (c) material rupture due to pull-through of the fasteners, and (d) tension failure of the framing components. Shear walls and diaphragms shall be designed such that

$$D_u \leq \lambda \phi_t D_n \quad (7.8.7-1)$$

where

D_u = Required diaphragm strength per unit length

ϕ_t = 0.65

D_n = Nominal diaphragm strength per unit length

Shear walls and diaphragms shall be designed according to either the following beam analogy or, alternatively, by more refined structural analysis procedures. Design shall include consideration of sheathing (pultruded plate), framing (pultruded sections), fasteners, fastening schedule, all boundary members (pultruded sections), boundary member splices, drag struts, and all required connections. Force transfer to a supporting system not covered by these provisions shall be in accordance with applicable building code provisions.

Shear walls and diaphragms and their elements and components shall be analyzed as thin, deep beams with the plate resisting in-plane shear (as in a built-up beam web) and the boundary members resisting axial forces (as in built-up beam flanges). Boundary elements shall be provided at shear wall and diaphragm perimeters, and at interior openings, discontinuities, and re-entrant corners, unless not required as shown by analysis. Provisions shall be made to dissipate forces from boundary elements at openings and discontinuities into the body of the shear wall or diaphragm.

The required shear wall or diaphragm resistance is established by the controlling factored lateral load case. Determination of the controlling factored lateral load case shall include wind or seismic forces acting along each of the structure's principal axes and orthogonal effects, as specified in the governing building code or ASCE 7-10.

The pultruded vertical (studs) and horizontal frame members shall be an integral part of the shear wall assembly. Shear forces between the framing and the plate shall be transmitted by fasteners, or a combination of fasteners and adhesives.

The nominal tensile strength of pultruded frame and boundary members shall comply with the requirements set forth in Sections 3.2 and 7.5. Plates and frame members shall be connected by fasteners in compliance with the requirements for bolted connections set forth in Section 8.2 unless qualification tests show that a higher strength can be substantiated by structural grade adhesives.

7.9 Design of Decking Members

7.9.1 Design Basis

Decking members include decking, roofing and flooring systems consisting of two or more pultruded components connected together. Decking members shall be connected so that the assembly acts as a unit with forces distributed in proportion to component stiffnesses. Decking members comprise planks, panels, connectors, hangers and end caps. Decking members shall be designed to interconnect resulting in a continuous solid surface.

Testing of decking members shall be conducted according to the requirements of Section 1.7.3 (b) whenever adequate supporting data for design is not available or full composite action is not guaranteed. The strength of decking members assembled from connected components shall be determined using a transformed section analysis unless a different value is substantiated by testing. Where the composition or configuration of decking members is such that compliance with the provisions of this Standard cannot be determined by analysis, it is permitted to establish such compliance on the basis of test results that are evaluated in accordance with Section 2.3.2.

7.10 Design of Plates for Serviceability

Plates and built-up members shall be designed to have adequate stiffness in accordance with the provisions in Section 1.4.4.

8. DESIGN OF BOLTED CONNECTIONS

This chapter provides provisions for design of bolted connections of pultruded FRP structural shapes and plates. It is organized as follows:

- 8.1 Scope
- 8.2 General Design Requirements
- 8.3 Connection Design
- 8.4 Column Bases and Bearing on Concrete

8.1 Scope

The design provisions of this chapter apply to *bearing-type* bolted connections for pultruded FRP shapes and plates and other FRP and/or metallic components, referred to hereafter as members, and comply with the requirements specified in Section 8.2 general Provisions. Connections of pultruded FRP members can be direct (member to member), or can incorporate connecting elements (e.g., gussets, splice plates, and angles) using steel or stainless steel bolts. Connecting elements are to be of steel, stainless steel or aluminium. FRP connection elements are allowed where connections are pre-qualified by testing in accordance with Section 2.3.2. The chapter provides guidelines for initial sizing of FRP connection elements. Design of steel connection components shall be accordance with ANSI/AISC specifications.

Connections in FRP structures using FRP nuts and bolts, or solid unidirectional reinforced FRP rods are permitted if tested as indicated in Section 2.3.2 – Prequalified FRP Building Products.

Reference to bolts in this chapter shall apply only to steel bolts and Sections 8.2.2 and 8.3.2.1.

The types of connection covered shall be lap shear configuration with the loading principally in-plane of the connecting members.

This chapter does not apply to bolted connections (Figure 8.1) with more than three bolts in a line that is parallel to the direction of the connection force or/and with three or more bolts in a single line with the connection force acting perpendicular to this line of bolting. Connection detailing with more than three bolts per row and/or with more than three rows must be shown by testing (in accordance with Section 2.3.2) or analysis to be justified. Double row joints may be justified over only a single row for stability to resist compressive loads. Design of bearing-type connections in this chapter do not require the bolting to be combined with adhesive bonding.

The nominal strengths appropriate to the material of an element in the bolted connection shall be used with the strength formulae in this Chapter.

Where bolts are required to carry tensile forces between the members joined, the connection components shall be designed to resist the additional out-of-the-plane force due to prying action, where this occurs.

All requirements established in this chapter are subjected to the limitation established in Section 1.1.1.

8.1.1 Axially Loaded Connection Types

8.1.1.1 Angles and Channels

In the case of unsymmetrical or unsymmetrically connected members, such as angles and channels, the eccentricity of bolts in end connection and the effects of the spacing and edge distances of bolts shall be taken into account when determining the nominal strength.

8.1.2 Placement of Bolts

Members meeting at a connection should be arranged with centroidal axes intersecting at a point. Any kind of eccentricity in the connection nodes shall be taken into account. Groups of bolts at the ends of any member, which transmit axial force into that member, shall be sized so that the center of gravity of the group coincides with the center of gravity of the member. The foregoing provision is not applicable to end connections of statically loaded angle, double angle and similar members.

8.1.3 Framing Connections

Simple frame connections shall have either a pair of clip angles of FRP leg-angle or a pair of clip angles of steel leg-angle. Where it is not possible to fix a pair of angles a single-sided clip angle connection may be used providing the detailing is shown by testing, in accordance with 2.3.2, to be justified.

8.2 General Provisions

8.2.1 Scope

This section lists the requirements that shall be used for bolts, nuts and washers in bolted connections between FRP components and between FRP and steel components, as well as minimum geometry requirements for bolted connections.

8.2.1.1 Braced System and Column Splice Connections

The design strength of connections shall be determined in accordance with the provisions in this chapter and the design requirement provisions of Chapter 2.

The nominal strength of the connection shall be determined by structural analysis for the design loads, consistent with the type of construction specified, or shall be a proportion of the nominal strength of the connected members when so specified herein.

8.2.2 Bolts

Bolts shall be of carbon or stainless steels with specification in accordance with ASTM standards A307, A325 or F593. Bolts shall be in the range of diameters, d , from 3/8 in. (9.53 mm) up to, and including, 1 in. (25.4 mm). The bolt length shall be such that the end of the bolt extends beyond or is at least flush with the outer face of the nut when properly installed. The length of the bolt shank with thread that is in bearing with FRP material should not exceed 1/3rd of the thickness of the plate component. Bolts shall be torqued to the snug-tightened condition.

The slope parts in contact with the washer the bolt head and nut shall be equal to or less than 1:20 with respect to a plane that is perpendicular to the bolt axis.

8.2.3 Size and Use of Bolt Holes

The nominal hole diameter, d_n , shall be 1/16 in. (1.6 mm) larger than the nominal bolt diameter, d . Holes must be drilled or reamed.

Oversized holes greater than 1/16 in. (1.6 mm) larger than bolt shall not be permitted, and slotted holes shall not be aligned in the primary direction of connection force (refer also to Section 2.9).

8.2.4 Nuts and Washers

Nuts shall be of steel with specification in accordance with ASTM standard A563 for bolts according to ASTM A307 or A325 and in accordance with standard F594 for F593 bolts. Washers for A307 or A325 bolts shall be supplied in accordance to ASTM A436 or F844. Washers for stainless steel bolts shall meet size requirements to ASTM A436 but should be of compatible stainless steel grades to the bolts and nuts.

Hardened flat circular steel washers shall have an outer diameter (d_w) at least twice the nominal bolt diameter d , and to have a thickness not less than 5/32 in. (4.0 mm). At least one such washer shall be used at the head of the bolt and at the nut. In addition to flat washers the use of lock washers between the nut and flat washer may be used.

8.2.5 Connection Geometry Requirements

Figure 8.1 defines connection geometry and for the situation shown defines a row of bolts to have its centreline perpendicular to the direction of the connection force. The minimum requirements for end distance e_1 , edge distance e_2 , stagger distance l_s , pitch s (the bolt spacing between bolt rows) and gage g (the bolt spacing across a row), (or g_s , when bolts are staggered) shall be taken from Table 8.1. The maximum spacing between bolts shall be 12 times the minimum thickness of the FRP material for the components bolted together. Connections can have up to three rows of three bolts, but the bolt size (and grade), hole size and bolt spacings in a connection must remain constant.

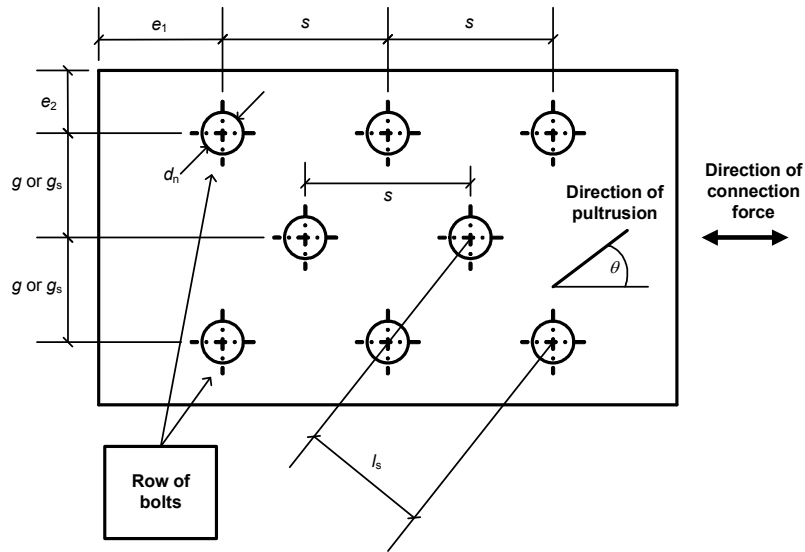

Figure 8.1 Connection geometry and definition for a row of bolts.

Table 8.1 Minimum requirements for bolted connection geometries.

| Notation | Definition | Minimum required spacing (or distance in terms of bolt diameters) |
|-------------------|-------------------------------------|--|
| $e_{1,min}^{[b]}$ | End distance Single row of bolts | Tension load $4d^{[a]}$ |
| | Two or three bolt rows | $2d$ |
| | End distance All connections | Compression load $2d$ |
| $e_{2,min}$ | Edge distance | $1.5d$ |
| $s_{min}^{[c]}$ | Pitch spacing | $4d$ |
| g_{min} | Gage spacing | $4d$ |
| $g_{s,min}$ | Gage spacing with staggered bolts | $2d$ |
| $l_{s,min}$ | Stagger distance | $2.8d$ |

Notes:

- [a] d is the nominal diameter of bolt.
- [b] Minimum $e_{1,min}$ may be reduced to $2d$ when the connected member has a perpendicular element attached to the end that the connection force is acting towards.
- [c] When s_{min} cannot be met the connection strength shall be reduced according to the geometry factor C_{Δ} in section 8.3.1.1.

8.3 Connection Design

8.3.1 Scope

The design strength shall defined as $\lambda\phi R_n$, where R_n is defined as the nominal strength adjusted for end use condition in accordance with Section 2.4. The strength of a bolted connection shall be determined on the basic of the strength of its basic components. Strength shall be determined for all possible critical failure paths. Connections shall be designed such that

$$R_u \leq \lambda\phi R_n C_{\Delta} C_M C_T \quad (8.3.1-1)$$

where

- R_u = Ultimate connection strength due to factored loads
- ϕ = Either resistance factor ϕ_b for steel bolt, as specified in Section 8.3.2-1, or resistance factor ϕ_c for FRP connections with strength formula
- λ = Time effect factor specified in Table 2.3-1
- R_n = Nominal connection strength determined in accordance with Sections 8.3.2 and 8.3.3
- C_{Δ} = Geometry factor which takes into account the connection geometry, determined in accordance with Section 8.3.1.1
- C_M = Moisture condition factor in Table 2.4-1
- C_T = Temperature condition factor in Table 2.4-1

When connection strength cannot be realized with existing FRP wall thicknesses the local thickness shall be increased by adhesively bonding and mechanical fastening (during shop fabrication) an FRP component to increase the strength to the required level.

8.3.1.1 Geometry Factor

If the requirements from Table 8.1 are met, $C_{\Delta} = 1.0$.

When the pitch spacing, s , is greater than or equal to s_{min} specified in Table 8.1, then $C_{\Delta} = 1.0$.

When $4d \leq s < s_{min}$, $C_{\Delta} = s/s_{min}$.

For the through-the-thickness strength (R_{tt}) of Section 8.3.2.2, $C_{\Delta} = 1.0$ always.

8.3.2 Nominal Strength of Single Row Bolted Connections

When the material is FRP the nominal connection strength, R_n , shall be taken as the minimum of R_{bt} , R_{tt} , R_{br} , R_{nt} , R_{sh} , and R_{cl}

where

R_{bt} = Bolt strength, calculated in Section 8.3.2.1

R_{tt} = Tension (through-the-thickness) strength, calculated in Section 8.3.2.2

R_{br} = Pin-bearing strength, calculated in Section 8.3.2.3

R_{nt} = Net tension strength, calculated in Section 8.3.2.4

R_{sh} = Shear-out strength, calculated in Section 8.3.2.5

R_{cl} = Cleavage strength, calculated in Section 8.3.2.6

Figure 8.3 defines the directions of the connection force for the five strengths for the FRP material.

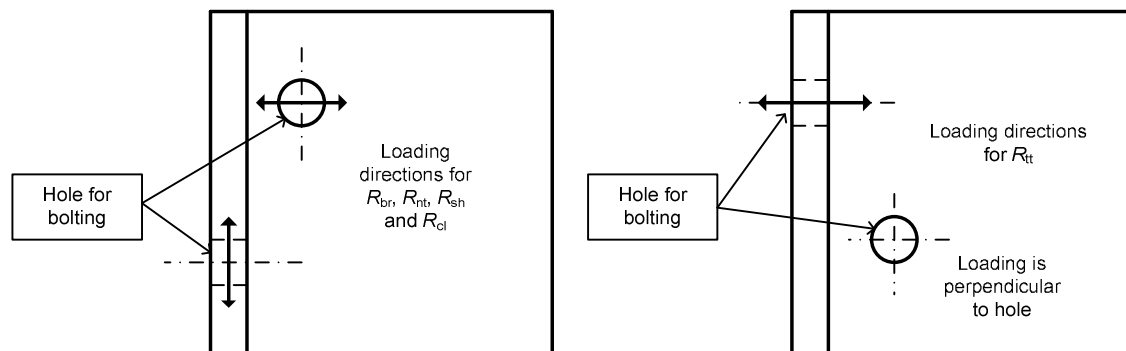

Figure 8.2. Loading directions for FRP material strengths.

Sections 8.3.2.1 to 8.3.2.6, excluding 8.3.2.3, shall apply to connections with a single row of bolts and constant thickness of the FRP member or connecting component. Connection strength assumes that each bolt in a single row of bolts (with maximum number of bolts is three) is equally loaded. A row of bolts has the connection force acting perpendicular to the alignment axis for the bolts.

R_{tt} is for connections with prying action and a connection force component that is aligned with the axis of bolting.

R_{br} , R_{nt} , R_{sh} , and R_{cl} are for connections in double lap shear when a connection force component is in the plane of the connection. When the connection is for single lap shear the strength calculated shall be reduced by 40 percent.

The connection strengths of R_{sh} and R_{cl} need not be determined when there is a perpendicular element (e.g. the flanges in channels, I-shaped or box-profiles) of FRP at the end of the pultruded member or connecting component of FRP material.

The connection strength R_{nt} need not be determined when there are two perpendicular elements (e.g. the flanges in channels, I-shaped or box-profiles) having their planes aligned with the connection force. When there is only one perpendicular element (e.g. leg-angle) the net-tension strength shall be determined from the provision in 8.3.2.4.

8.3.2.1 Tension and Shear Strength of Bolts, R_{bt}

The design tension or shear strength, ϕ_b , of steel bolt shall be determined according to the limit states of tensile rupture and shear rupture as follows:

$$R_{bt} = F_n A_b \quad (8.3.2-1)$$

$$\phi_b = 0.75$$

where

F_n = Nominal tensile strength F_{nt} , or nominal shear strength F_{nv} , of steel bolt is either from Table 8.2 or from ASTM F593 with $F_{nv} = 0.66F_{nt}$, as threads are excluded from the shear plane

A_b = Nominal unthreaded body area of bolt.

Table 8.2. Nominal strength of bolts.

| Applied load condition | | Nominal strength per unit area, F_n | | |
|------------------------|-----------------------------------|---------------------------------------|---------------------|--------------------------|
| | | ASTM A325 | ASTM A307 | ASTM F593 ^[b] |
| Tension, F_{nt} | Static | 90 ksi (620 MPa) | 60 ksi (419 MPa) | 60 ksi (419 MPa) |
| Shear, F_{nv} | Threads excluded from shear plane | 68 ksi ^[a] (415 MPa) | 48 ksi (331 MPa) | 48 ksi (331 MPa) |

Notes:

[a] When threads are excluded from the shear plane.

[b] Lowest strength for stainless steel in Alloy Group 1 (304) and Alloy Group 2 (316).

The nominal strength shall be the sum of factored loads and any tension resulting from prying action produced by deformation of the connected parts.

The available tensile strength of a bolt to combined tension and shear shall be determined according to the limit states of tension and shear rupture as follows:

$$R_{bt} = F_{nt}^t A_b \quad (8.3.2-2)$$

$$\phi_b = 0.75$$

where

$$F_{nt}^t = \text{Nominal tensile strength modified to include effect of shear stress}$$

$$F_{nt}^t = 1.3F_{nt} - \frac{F_{nt}}{\phi_b F_{nv}} f_v \leq F_{nt} \quad (8.3.2-2a)$$

F_{nt} = Nominal tensile stress either from Table 8.2 or from ASTM F593

F_{nv} = Nominal shear stress either from Table 8.2 or from $F_{nv} = 0.66F_{nt}$, as threads are excluded from the shear plane and with F_{nt} from ASTM F593

f_v = Required shear stress.

The available shear stress of the bolt shall equal or exceed the required shear strength per unit area, f_v .

8.3.2.2 Tension (through-the-thickness) Strength, R_{tt}

The nominal tension (through-the-thickness) strength per bolt shall be the lesser of:

$$R_{tt} = 0.5 \pi d_w t F_{sh,tt} \quad (8.3.2-3a)$$

$$\phi_c = 0.5$$

and

$$R_{tt} = 0.4 \pi d_w t F_{sh,int} \quad (8.3.2-3b)$$

$$\phi_c = 0.5$$

where

d_w = Nominal diameter of the washer

t = Thickness of FRP material resisting the through-the-thickness tension

$F_{sh,tt}$ = Characteristic shear strength in the through-the-thickness plane of the FRP material, taken to be the characteristic in-plane shear strength F_{sh}

$F_{sh,int}$ = Characteristic interlaminar shear strength of the FRP material.

The nominal strength, R_{tt} , does not need to be considered in situations where the bolts connecting two or more planes of FRP material are in pure in-plane shear loading (as shown for the bolted connections in the left-handed figure in Figure 8.3) and not subjected to prying loading (as shown in for the bolted connections in the right-handed figure in Figure 8.3).

8.3.2.3 Pin-bearing Strength, R_{br}

The perpendicular pin-bearing strength per bolt shall be given by

$$R_{br} = t d F_{\theta}^{br} \quad (8.3.2-4)$$

$$\phi_c = 0.8$$

where

t = Thickness of the FRP component and/or member

d = Nominal diameter of bolt (Section 8.2.3)

F_{θ}^{br} = Characteristic pin-bearing strength for the orientation of the resultant force at the bolt/FRP contact with respect to the direction of pultrusion, and as given by Equation (8.3.2-5).

$$F_{\theta}^{\text{br}} = F_{\text{L}}^{\text{br}} \text{ when } \theta \text{ is } \leq 5^{\circ}, \text{ and, } = F_{\text{T}}^{\text{br}} \text{ when } \theta \text{ is } > 5^{\circ} \text{ to } 90^{\circ}, \quad (8.3.2-5)$$

where

θ = Angle of loading, the orientation between the direction of the connection force and the direction of pultrusion or the principal direction of the FRP material (see Figure 8.1)

F_{L}^{br} = Characteristic pin-bearing strength in the longitudinal direction of FRP

F_{T}^{br} = Characteristic pin-bearing strength in the transverse direction, which is perpendicular to the longitudinal direction of FRP.

If, on one of the two sides to a bolted connection, there is no washer and no nut (there will be a washer and nut or bolt head on the other side) the characteristic pin-bearing strength (F_{θ}^{br}) is to be reduced by a factor of 0.5.

8.3.2.4 Net tension Strength, R_{nt}

If the number of bolt rows is two or three the net tension strength shall be determined in accordance with Section 8.3.3.

For the situation where the connection force is between 0° to 5° to the longitudinal direction of FRP material perpendicular to a single row of bolts, (the maximum number of bolts in the row is set to three) the nominal net tension strength shall be given by

$$R_{\text{nt}} = \frac{1}{K_{\text{nt,L}}} (w - n d_{\text{n}}) t F_{\text{L}}^{\text{t}} \quad (8.3.2-6a)$$

$$\phi_{\text{c}} = 0.5$$

where

t = Minimum thickness of the connected component and/or member

d_{n} = Nominal hole diameter (Section 8.2.3)

n = Number of bolts across the effective width, $n = 1$ to 3

F_{L}^{t} = Characteristic tensile strength in the longitudinal direction of the FRP material.

For a single bolt connection ($n = 1$ and $S_{\text{pr}} = w/d$):

$K_{\text{nt,L}}$ in Equation (8.3.2-6a) is given as follows:

$$K_{\text{nt,L}} = C_{\text{L}} \left(S_{\text{pr}} - 1.5 \frac{(S_{\text{pr}} - 1)}{(S_{\text{pr}} + 1)} \Theta \right) + 1 \quad (8.3.2-7a)$$

$$\text{with } \Theta = 1.5 - 0.5 \frac{w}{e_1} \text{ for } \frac{e_1}{w} \leq 1, \quad \text{and} \quad \Theta = 1 \text{ for } \frac{e_1}{w} \geq 1.$$

When the pultruded material is from a shape $C_{\text{L}} = 0.50$, and when it is from plate $C_{\text{L}} = 0.40$.

The effective width (w) in Equation (8.3.2-6a) and (8.3.3-7a) shall be $w = e_3 + e_4$, and:

$e_3 = e_4 = e_2$, for a connection with two side edges having a side distance e_2 ;

$e_3 = e_2$, $e_4 = 2e_{2,\min}$, for a connection with one side edge having side distance e_2 and with the other side distance $\gg e_{2,\min}$;

$e_3 = e_4 = 2e_{2,\min}$, for a connection having its two side edges with side distance $\gg e_{2,\min}$.

For a single row of bolts with constant gage spacing across the effective width ($n = 2$ or 3 take $S_{pr} = g/d$):

$K_{nt,L}$ in Equation (8.3.2-6a) is given as follows:

$$K_{nt,L} = C_L \left(S_{pr} - 1.5 \frac{(S_{pr} - 1)}{(S_{pr} + 1)} \Theta \right) + 1 \quad (8.3.2-7b)$$

$$\text{with } \Theta = 1.5 - 0.5 \frac{g}{e_1} \text{ for } \frac{e_1}{g} \leq 1, \quad \text{and } \Theta = 1 \text{ for } \frac{e_1}{g} \geq 1.$$

When the pultruded material is from a shape $C_L = 0.50$, and when it is from plate $C_L = 0.40$.

The effective width (w) in Equation (8.3.2-6a) and (8.3.2-7b) shall be $w = e_3 + e_4 + (n - 1)g$, where n is number of bolts ($n_{\max} = 3$), and:

$e_3 = e_4 = e_2$, for a connection with two side edges having a side distance e_2 ;

$e_3 = e_2$, $e_4 = 2e_{2,\min}$, for a connection with one side edge having side distance e_2 and with the other side distance $\gg e_{2,\min}$;

$e_3 = e_4 = 2e_{2,\min}$, for a connection having its two side edges with side distance $\gg e_{2,\min}$.

For the situation where the connection force is from 5° to 90° to the longitudinal direction of FRP material and perpendicular to a single row of bolts (the maximum number of bolts in row is set to three) the strength shall be given by

$$R_{nt} = \frac{1}{K_{nt,T}} (w - nd_n) t F_T^t \quad (8.3.2-6b)$$

$$\phi_c = 0.5$$

where

t = Minimum thickness of the connected members

d_n = Nominal hole diameter (Section 8.2.3)

n = Number of bolts across the effective width, $n = 1$ to 3

F_T^t = Characteristic tensile strength in the transverse direction of the FRP material.

For a single bolt connection ($n = 1$) and $S_{pr} = w/d$):

$K_{nt,T}$ in Equation (8.3.2-6b) is given as follows:

$$K_{nt,T} = C_T \left(S_{pr} - 1.5 \frac{(S_{pr} - 1)}{(S_{pr} + 1)} \Theta \right) + 1 \quad (8.3.2-8a)$$

$$\text{with } \Theta = 1.5 - 0.5 \frac{w}{e_1} \text{ for } \frac{e_1}{w} \leq 1, \quad \text{and } \Theta = 1 \text{ for } \frac{e_1}{w} \geq 1.$$

When the pultruded material is from a shape or plate $C_T = 0.50$.

The effective width (w) in Equation (8.3.2-6b) and (8.3.2-8a) shall be $w = e_3 + e_4$, and:

$e_3 = e_4 = e_2$, for a connection with two side edges having a side distance e_2 ;

$e_3 = e_2$, $e_4 = 2e_{2,\min}$, for a connection with one side edge having side distance e_2 and with the other side distance $\gg e_{2,\min}$;

$e_3 = e_4 = 2e_{2,\min}$, for a connection having its two side edges with side distance $\gg e_{2,\min}$.

For a single row of bolts with constant gage spacing across the effective width ($n = 2$ or 3 take $S_{pr} = g/d$):

$K_{nt,T}$ in Equation (8.3.2-6b) is given as follows:

$$K_{nt,T} = C_T \left(S_{pr} - 1.5 \left(\frac{S_{pr} - 1}{S_{pr} + 1} \right) \Theta \right) + 1 \quad (8.3.2-8b)$$

with $\Theta = 1.5 - 0.5 \frac{g}{e_1}$ for $\frac{e_1}{g} \leq 1$, and $\Theta = 1$ for $\frac{e_1}{g} \geq 1$.

When the pultruded material is a structural shape or plate $C_T = 0.50$.

The effective width (w) in Equation (8.3.2-6b) and (8.3.2-8b) shall be $w = e_3 + e_4 + (n - 1)g$, where n is number of bolts ($n_{\max} = 3$), and:

$e_3 = e_4 = e_2$, for a connection with two side edges having a side distance e_2 ;

$e_3 = e_2$, $e_4 = 2e_{2,\min}$, for a connection with one side edge having side distance e_2 and with the other side distance $\gg e_{2,\min}$;

$e_3 = e_4 = 2e_{2,\min}$, for a connection having its two side edges with side distance $\gg e_{2,\min}$.

8.3.2.5 Shear-out Strength, R_{sh}

The nominal shear-out strength per bolt, in a line that is parallel to the direction of the connection force, shall be given, when $e_1 < 4d = e_{1,\min}$, by:

$$R_{sh} = 1.4 \left(e_1 - \frac{d_n}{2} \right) t F_{sh} \quad (8.3.2-9a)$$

$\phi_c = 0.5$

where

t = Minimum thickness of the connected members

F_{sh} = Characteristic in-plane shear strength of FRP material appropriate to the mode of failure.

8.3.2.6 Cleavage Strength, R_{cl}

For the situation where the connection force is tensile and parallel to the direction of FRP material, the nominal cleavage strength per bolt shall be given by:

Only for the case of a single bolt, centrally positioned, and when $e_1 < 4d = e_{1,\min}$, is the lesser of:

$$R_{cl} = 0.15 \left((2e_2 - d_n) F_L^t + 2e_1 F_{sh} \right) t \quad (8.3.2-10a)$$

$$\phi_c = 0.5$$

and

$$R_{cl} = \left(\frac{10}{9} - \frac{4}{9} \frac{d_n}{e_1} \right)^2 R_{br} \quad \text{for } \frac{e_1}{d} < 4, \text{ or } R_{cl} = R_{br} \text{ for } \frac{e_1}{d} \geq 4. \quad (8.3.2-10b)$$

$$\phi_c = 0.5$$

where

R_{br} is given by Equation (8.3.2-4).

For the case of a row of bolts (with the maximum number of bolts in the row set to three) at uniform gage spacing g :

$$R_{cl} = 0.15 \left((e_2 + 0.5g - d_n) F_{t,L} + 2e_1 F_{sh} \right) t \quad (8.3.2-10c)$$

$$\phi_c = 0.5$$

where

t = Minimum thickness of the connected members

F_{sh} = Characteristic in-plane shear strength appropriate to the mode of failure

F_L^t = Characteristic tensile strength of the FRP material in the longitudinal direction.

When the connection force is compressive or perpendicular to the direction of pultrusion cleavage failure shall not apply.

8.3.3 Nominal Strength of Bolted Connections with Two or Three Rows of Bolts

The nominal connection strength, R_n , shall be taken as the minimum of R_{bt} , R_{tt} , R_{br} , $R_{nt,f}$, R_{sh} , and R_{bs}

where

R_{bt} = Bolt strength, calculated in Section 8.3.2.1

R_{tt} = Tension (through-the-thickness) strength, calculated in Section 8.3.2.2

R_{br} = Pin-bearing strength, calculated in Section 8.3.2.3

$R_{nt,f}$ = Net tension strength at first bolt row, calculated in Section 8.3.3.2

R_{sh} = Shear-out strength, calculated in Sections 8.2.3.5 and 8.3.3.3

R_{bs} = Block shear strength for concentric load, calculated in Section 8.3.3.4.

$R_{bs,e}$ = Block shear strength for eccentric load, calculated in Section 8.3.3.4.

Sections 8.3.2.1 to 8.3.2.3 shall apply to connections with a single row of bolts and having constant thickness of the FRP member or connecting component. It is assumed that the nominal strength of the multi-row connection, failing with one of these three modes, is the summation of the equal strength contributions from each of the bolts using the appropriate provision in Sections 8.3.2.1 to 8.3.2.3.

The formula R_{tt} is for connections with prying action and a connection force component that is aligned with the axis of bolting.

The formulae for R_{br} , $R_{nt,f}$, R_{sh} , R_{bs} and $R_{bs,e}$ are for multi-row bolted connections in double lap shear. When the multi-row connection is for single lap shear the strength calculated shall be reduced by 40 percent.

The connection strengths of R_{sh} and R_{cl} need not be determined when there is a perpendicular element (e.g. the flanges in channels, I-shaped or box-profiles) of FRP at the end of the pultruded member or connecting component of FRP material.

The connection strength $R_{nt,f}$ need not be determined when there are two perpendicular elements (e.g. the flanges in channels, I-shaped or box-profiles) having planes aligned with the connection force. When there is only one perpendicular element (e.g. leg-angle or T-profiles) the strength shall be determined from the provision 8.3.3.2.

8.3.3.1 Load Distribution per Bolt Row

Table 8.3 gives the load distribution per bolt row as a proportion of the connection force transmitted through bearing. It shall be assumed that each row has the same number of bolts, up to a maximum number of three, and that each bolt in a row bears an equal part of the load resisted by that row. The proportion of the load not resisted by the first row shall be taken as the by-pass load $(1 - L_{br})$ in Section 8.3.3.2.

Table 8.3. Load distributions for multi-bolted connections with two or three bolt rows.

| Materials connected | No. of rows, n | Proportion of load at first row ^[b] , L_{br} | Proportion of load at second row | Proportion of load at third row |
|-------------------------|------------------|---|----------------------------------|---------------------------------|
| FRP ^[a] /FRP | 2 | 0.5 | 0.5 | ---- |
| FRP/steel | 2 | 0.6 | 0.4 | ---- |
| FRP/FRP | 3 | 0.4 | 0.2 | 0.4 |
| FRP/steel | 3 | 0.5 | 0.3 | 0.2 |

Notes:
[a] FRP is for Fiber Reinforced Polymer material.
[b] First row of bolts is the farthest from the end edge of the connection.

8.3.3.2 Net tension Strength at First Bolt Row, $R_{nt,f}$

For determination of net tension strength, $R_{nt,f}$, the bolt loading at the first row shall be given by the load distribution proportions in Table 8.3.

For the situation where the connection force is between 0° and 5° to the longitudinal direction of FRP material and perpendicular to the bolt rows, with constant pitch spacing (s , the nominal net tension strength shall be given by:

$$R_{nt,f} = \left[\left(K_{nt,L} L_{br} \left(\frac{w}{nd} \right) \right) + \left(\frac{K_{op,L} (1 - L_{br})}{\left(1 - n \left(\frac{d_n}{w} \right) \right)} \right) \right]^{-1} w t F_L^t \quad (8.3.3-1a)$$

$$\phi_c = 0.45$$

where

t = Minimum thickness of the connected members

d = Bolt diameter (Section 8.2.3)

d_n = Nominal hole diameter (Section 8.2.3)

n = Number of bolts across the effective width, $n = 1$ to 3 .

L_{br} = Proportion of the connection force taken in bearing at the first bolt row

F_L^t = Characteristic tensile strength in the longitudinal direction of the FRP material.

For a connection with a single bolt per row ($n=1$ and $S_{pr} = w/d$):

$K_{nt,L}$ in Equation (8.3.3-1a) is given as follows:

$$K_{nt,L} = \frac{1}{\left(\frac{w}{nd} - 1\right)} \left(1 + C_L \left(S_{pr} - 1.5 \frac{(S_{pr} - 1)}{(S_{pr} + 1)} \Theta \right) \right) \quad (8.3.3-2a)$$

$$\text{with } \Theta = 1.5 - 0.5 \frac{w}{e_1} \text{ for } \frac{e_1}{w} \leq 1, \quad \text{and} \quad \Theta = 1 \text{ for } \frac{e_1}{w} \geq 1.$$

When the pultruded material is a shape $C_L = 0.50$, and when it is plate $C_L = 0.40$.

The effective width (w) in Equations (8.3.3-1a) and (8.3.3-2a) shall be $w = e_3 + e_4$, and:

$e_3 = e_4 = e_2$, for a connection with two side edges having a side distance e_2 ;

$e_3 = e_2$, $e_4 = 2e_{2,min}$, for a connection with one side edge having side distance e_2 and with the other side distance $\gg e_{2,min}$;

$e_3 = e_4 = 2e_{2,min}$, for a connection having its two side edges with side distance $\gg e_{2,min}$.

$K_{op,L}$ in Equation (8.3.3-1a) is given by:

$$K_{op,L} = 1 + C_{op,L} \left(1 + \left(1 - \frac{1}{S_{pr}} \right)^3 \right) \quad (8.3.3-3a)$$

When the pultruded material is a shape or is a plate $C_{op,L} = 0.50$.

For rows of bolts with constant gage spacing across the effective width ($n = 2$ or 3 take $S_{pr} = g/d$):

$K_{nt,L}$ in Equation (8.3.3-1a) is given as follows:

$$K_{nt,L} = \frac{1}{\left(\frac{w}{nd} - 1\right)} \left(1 + C_L \left(S_{pr} - 1.5 \frac{(S_{pr} - 1)}{(S_{pr} + 1)} \Theta \right) \right) \quad (8.3.3-2b)$$

$$\text{with } \Theta = 1.5 - 0.5 \frac{g}{e_1} \text{ for } \frac{e_1}{g} \leq 1, \quad \text{and} \quad \Theta = 1 \text{ for } \frac{e_1}{g} \geq 1.$$

When the pultruded material is a shape $C_L = 0.50$, and when it is plate $C_L = 0.40$.

The effective width (w) in Equations (8.3.3-1a) and (8.3.2-2b) shall be $w = e_3 + e_4 + (n - 1)g$, where n is number of bolts across the effective width ($n_{max} = 3$), and:

$e_3 = e_4 = e_2$, for a connection with two side edges having a side distance e_2 ;

$e_3 = e_2$, $e_4 = 2e_{2,\min}$, for a connection with one side edge having side distance e_2 and with the other side distance $\gg e_{2,\min}$;

$e_3 = e_4 = 2e_{2,\min}$, for a connection having its two side edges with side distance $\gg e_{2,\min}$.

$K_{op,L}$ in Equation (8.3.3-1a) is given by:

$$K_{op,L} = 1 + C_{op,L} \left(1 + \left(1 - \frac{1}{S_{pr}} \right)^3 \right) \quad (8.3.3-3b)$$

When the pultruded material is a shape or is a plate $C_{op,L} = 0.50$.

For the situation where the connection force is from 5° to 90° to the longitudinal direction of FRP material and perpendicular to the bolt rows, with constant spacing (s), the strength shall be given by:

$$R_{nt,f} = \left[\left(K_{nt,T} L_{br} \left(\frac{w}{nd} \right) \right) + \left(\frac{K_{op,T} (1 - L_{br})}{\left(1 - n \left(\frac{d_n}{w} \right) \right)} \right) \right]^{-1} wt F_T^t \quad (8.3.3-1b)$$

$\phi_c = 0.45$

where

t = Minimum thickness of the connected members

d = Bolt diameter (Section 8.2.3)

d_n = Nominal hole diameter (Section 8.2.3)

n = Number of bolts across the effective width, $n = 1$ to 3 .

L_{br} = Proportion of the connection force taken in bearing at the first bolt row

F_T^t = Characteristic tensile strength in the transverse direction of the FRP material.

For a connection with a single bolt per row ($n = 1$ and $S_{pr} = w/d$):

$K_{nt,T}$ in Equation (8.3.3-1b) is given as follows:

$$K_{nt,T} = \frac{1}{\left(\frac{w}{nd} - 1 \right)} \left(C_T \left(S_{pr} - 1.5 \frac{(S_{pr} - 1)}{(S_{pr} + 1)} \Theta \right) + 1 \right) \quad (8.3.3-2c)$$

with $\Theta = 1.5 - 0.5 \frac{w}{e_1}$ for $\frac{e_1}{w} \leq 1$, and $\Theta = 1$ for $\frac{e_1}{w} \geq 1$.

When the pultruded material is a shape $C_T = 0.50$, and when it is flat sheet $C_T = 0.40$.

The effective width (w) in Equations (8.3.3-1b) and (8.3.3-2c) shall be $w = e_3 + e_4$, and:

$e_3 = e_4 = e_2$, for a connection with two side edges having a side distance e_2 ;

$e_3 = e_2$, $e_4 = 2e_{2,\min}$, for a connection with one side edge having side distance e_2 and with the other side distance $\gg e_{2,\min}$;

$e_3 = e_4 = 2e_{2,\min}$, for a connection having its two side edges with side distance $\gg e_{2,\min}$.

$K_{op,T}$ in Equation (8.3.3-1b) is given by:

$$K_{op,T} = 1 + C_{op,T} \left(1 + \left(1 - \frac{1}{S_{pr}} \right)^3 \right) \quad (8.3.3-3c)$$

When the pultruded material is a shape or a plate $C_{op,T} = 0.50$.

For rows of bolts with constant gage spacing across the effective width ($n = 2$ or 3 take $S_{pr} = g/d$):

$K_{nt,T}$ in Equation (8.3.3-1b) is given as follows:

$$K_{nt,T} = \frac{1}{\left(\frac{w}{nd} - 1 \right)} \left(C_T \left(S_{pr} - 1.5 \frac{(S_{pr} - 1)}{(S_{pr} + 1)} \Theta \right) + 1 \right) \quad (8.3.3-2d)$$

with $\Theta = 1.5 - 0.5 \frac{g}{e_1}$ for $\frac{e_1}{g} \leq 1$, and $\Theta = 1$ for $\frac{e_1}{g} \geq 1$.

When the pultruded material is a shape $C_T = 0.50$, and when it is plate $C_T = 0.40$.

The effective width (w) in Equations (8.3.3-1b) and (8.3.2-2d) shall be $w = e_3 + e_4 + (n - 1)g$, where n is number of bolts across the effective width ($n_{\max} = 3$), and:

$e_3 = e_4 = e_2$, for a connection with two side edges having a side distance e_2 ;

$e_3 = e_2$, $e_4 = 2e_{2,\min}$, for a connection with one side edge having side distance e_2 and with the other side distance $\gg e_{2,\min}$;

$e_3 = e_4 = 2e_{2,\min}$, for a connection having its two side edges with side distance $\gg e_{2,\min}$.

$K_{op,L}$ in Equation (8.3.3-1b) is given by:

$$K_{op,T} = 1 + C_{op,T} \left(1 + \left(1 - \frac{1}{S_{pr}} \right)^3 \right) \quad (8.3.3-3d)$$

When the pultruded material is a shape or a plate $C_{op,T} = 0.50$.

8.3.3.3 Shear-out Strength between Rows of Bolts, R_{sh}

For two rows of bolts ($n = 2$) separated by pitch spacing, s , the shear-out strength per line of bolts shall be given by:

$$R_{sh} = 1.4 \left(e_1 - \frac{d_n}{2} + s \right) t F_{sh} \quad (8.3.3-4)$$

$$\phi_c = 0.45$$

For three rows of bolts ($n = 3$) separated by pitch spacing, s , the shear-out strength per line of bolts shall be given by:

$$R_{sh} = 2((n - 1)s)t F_{sh} \quad (8.3.3-5)$$

$$\phi_c = 0.45$$

where

- t = Minimum thickness of the connected members
- d_n = Nominal hole diameter (Section 8.2.3)
- F_{sh} = Characteristic in-plane shear strength of FRP material appropriate to the mode of failure.

When the number of rows of bolts is two or three, block shear shall be considered, in accordance with 8.3.3.4.

8.3.3.4 Block Shear Strength, R_{bs}

When the connection force is concentric to the group of bolts, tensile and parallel to the direction of FRP material the nominal block shear strength for the multi-bolted connection shall be given by:

$$R_{bs} = 0.5(A_{ns} F_{sh} + A_{nt} F_L^t) \quad (8.3.3-6a)$$

$$\phi_c = 0.45$$

For a bolt group subject to eccentric in-plane loading the nominal block shear strength for the multi-bolted connection shall be given by:

$$R_{bs,e} = 0.5(A_{ns} F_{sh} + 0.5 A_{nt} F_L^t) \quad (8.3.3-6b)$$

$$\phi_c = 0.45$$

where

- F_{sh} = Characteristic in-plane shear strength of FRP material appropriate to the shear-out failure
- F_L^t = Characteristic tensile strength of the FRP material in the longitudinal
- A_{ns} = Net area subjected to shear
- A_{nt} = Net area subjected to tension, where the bolts are staggered the total deducted in c determining A_{nt} shall be the greater of
 - (a) the maximum of the sectional area in any cross section perpendicular to the member axis, or
 - (b) $t(n d_n - \sum b_s)$

where

$$b_s = \text{Lesser of } \frac{s^2}{4 g_s} \text{ or } 0.65 g_s$$

- n = Number of holes extending in any diagonal or zig-zag line progressively across the member or part of the member ($n_{max} = 3$)

d_n = Nominal diameter of hole.

8.3.4 Frame Connections

The strength of a framing connection shall be determined on the basis of the strength of its basic components.

8.3.4.1 Simple Framing Connections

Simple connections to beams, girders, or trusses shall be designed to have sufficient rotational capacity and shall be proportioned for the reaction shear forces only, except as otherwise allowed by 2.3.2.

For beam-to-column connections there shall be a gap equal to 0.5 in. (12.7 mm) between the ends of a beam member and the flange or web of the column member.

8.3.4.1.1 Shear Strength of Clip Angle, $R_{sh,sp}$

The nominal shear strength at the knee of the clip angle shall be given by:

$$R_{sh,sp} = l_{sp} t_{sp} F_{sh} \quad (8.3.3-7)$$
$$\phi_c = 0.75$$

where

l_{sp} = Depth of shear plane at the fillet radius of the leg-angle profile

t_{sp} = Minimum thickness of FRP material

F_{sh} = Characteristic in-plane shear strength appropriate to the shear-out failure.

8.3.4.2 Flexural Members with Splice Connections

- (a) A splice in a member or part subject to tension should be designed to transmit all the moments and forces to which the member or part is subjected at that point.
- (b) Wherever practicable the members should be arranged so that the centroid axis of any splice material coincides with the centroid axis of the member. If eccentricity is present then the resulting forces should be taken into account.
- (c) Splices in flexural members should comply with the following:
 - (i) Compression flanges should be treated as compression members;
 - (ii) Tension flanges should be treated as tension members;
 - (iii) Parts subjected to shear should be designed to transmit the following effects acting together:
 - the shear force at the splice;
 - the moment resulting from the eccentricity, if any, of the centroids of the group of bolts on each side of the splice;
 - the proportion of moment, deformation or rotations carried out by the web or part.

8.3.4.3 Compression Members with Bearing Connections

(a) When columns bear on bearing components or are finished to bear at splices, there shall be sufficient bolts to hold all parts securely in place.

(b) Splices should be designed to hold the connected members in place. Friction forces between contact surfaces may not be relied upon to hold connected members in place.

(c) Wherever practicable the members should be arranged so that the centroid axis of any splice material coincides with the centroid axis of the member. If eccentricity is present then the resulting forces should be taken into account.

(d) When compression members other than columns are finished to bear, the splice material and its connection shall be arranged to hold all parts in line and shall be proportioned for either e(i) or e(ii).

(e) It is permissible to use the less severe of the two conditions;

- (i) an axial tensile force of 50 percent of the required compressive strength of the member, or,
- (ii) the moment and shear resulting from a transverse load of 2 percent of the required compressive strength of the member. The transverse load shall be applied at the location of the splice, exclusive of other loads that act on the member. The member shall be taken as pinned for the determination of the shears and moments at the splice.

8.4 Column Bases and Bearing on Concrete

Proper provision shall be made to transfer the column forces and moments to footings and foundations.

In the absence of code regulation the design bearing strength $\phi_c P_p$ from the limit state of concrete crushing are permitted to be taken as $\phi_c = 0.6$.

The nominal bearing strength, P_p , is determined to be the lesser of the following:

(a) On the full area of a concrete support:

$$P_p = 0.85 f'_c A_1 \quad (8.3.3-8)$$

(b) On the less than the full area of a concrete support:

$$P_p = 0.85 f'_c A_1 \sqrt{A_2 / A_1} \leq 1.7 f'_c A_1 \quad (8.3.3-9)$$

where

f'_c = Characteristic minimum compressive strength of the concrete

A_1 = Area of FRP concentrically bearing on a concrete support

A_2 = Maximum area of the portion of the supporting surface that is geometrically similar to and concentric with the loaded area.

COMMENTARY

This Commentary consists of explanatory and supplemental material to the standard. In some cases it will be necessary to adjust specific values in the standard to local conditions; in others, a considerable amount of detailed information is needed to put the general provisions into effect. This Commentary provides a place for supplying material that can be used in these situations and is intended to create a better understanding of the recommended requirements through brief explanations of the reasoning employed in arriving at them.

The sections of this Commentary are numbered to correspond to the sections of the standard to which they refer. Since it is not necessary to have supplementary material for every section in the standard, there are gaps in the numbering in the Commentary.

TABLE OF CONTENTS - COMMENTARY

| | Page |
|---|-------------|
| C1. GENERAL PROVISIONS | 93 |
| C1.1 Scope | 93 |
| C1.1.1 Applicability and Exclusions | 93 |
| C1.1.2 Maximum Service Temperature | 93 |
| C1.1.3 Units | 93 |
| C1.2 Referenced Specifications, Codes and Standards | 93 |
| C1.3 Materials | 94 |
| C1.3.1 FRP Constituent Materials | 94 |
| C1.3.2 Physical and Mechanical Properties of Pultruded FRP Products | 94 |
| C1.3.3 Fire, Smoke and Toxicity | 95 |
| C1.3.4 Durability and Environmental Effects | 95 |
| C1.4 Design Basis | 95 |
| C1.4.1 Limit States Design | 95 |
| C1.4.2 General Analysis Requirements | 96 |
| C1.4.3 Design for Strength | 96 |
| C1.4.4 Design for Serviceability | 98 |
| C1.5 Loads and Load Combinations | 98 |
| C1.5.1. Nominal Loads | 98 |
| C1.5.2 Load Combinations for Strength Limit States | 99 |
| C1.5.3 Load Combinations for Serviceability Limit States | 99 |
| C1.6 Structural Design Drawings and Specifications | 100 |
| C1.7 Fabrication, Construction and Quality Assurance | 100 |
| References | 100 |
| C2. DESIGN REQUIREMENTS | 102 |
| C2.3 Design Strength | 102 |
| C2.3.1 Basic Strength Requirement | 102 |
| C2.3.2 Prequalified FRP Building Products | 109 |
| C2.4 Nominal Strength and Stiffness | 109 |
| C2.4.1 Nominal Strength | 109 |
| C2.4.2 Reference Strength and Stiffness | 109 |
| C2.4.3 Statistical Basis for Reference Strength and Stiffness | 110 |
| C2.4.4 Adjustments to Reference Strength | 111 |
| C2.4.5 Notches, Holes and Other Stress Concentrations | 111 |
| C2.5 Stability of Frames and Members | 112 |
| C2.5.1 General Requirements | 112 |
| C2.5.2 Design Requirements for Frame Stability | 112 |
| C2.5.3 Required Strength of Frames | 112 |
| C2.5.5 Bracing and Lateral Support | 113 |
| C2.6 Design for Serviceability | 114 |
| C2.6.1 Deformations | 114 |
| C2.6.2 Vibration | 115 |
| C2.7 Design for Ponding | 116 |
| C2.8 Design for Fatigue | 116 |

| | |
|--|------------|
| C2.9 Design of Connections | 117 |
| C2.10 Gross and Net Areas | 117 |
| C2.10.3 Effective Net Area | 117 |
| References | 117 |
| C3. DESIGN OF TENSION MEMBERS | 120 |
| C3.1 Scope | 120 |
| C3.3 Design Tensile Strength | 120 |
| C3.4 Built-Up Members | 121 |
| C3.5 Slenderness Limitations | 121 |
| References | 122 |
| C4. DESIGN OF MEMBERS IN COMPRESSION | 123 |
| C4.1 Scope | 123 |
| C4.2 General Provisions | 123 |
| C4.3 Slenderness and Effective Length Considerations | 123 |
| C4.3.1 Effective Member Length | 123 |
| C4.3.2 Effective Length Factor | 123 |
| C4.3.4 Compression Member Effective Slenderness Ratio | 124 |
| C4.4 Compression Strength of Commonly Available Sections | 124 |
| C4.4.1 Geometrically Symmetric I-Shaped Sections | 124 |
| C4.4.2 T-Shaped Sections | 126 |
| C4.4.3 Single Angle Sections with Equal Legs | 126 |
| C4.4.5 Square and Rectangular Tube Sections | 128 |
| C4.4.6. Circular Tube Sections | 128 |
| C4.5 Compression Strength for Members with Other Cross Sections | 129 |
| C4.6 Compression Strength for Built-Up Members | 129 |
| References | 129 |
| C5. DESIGN OF MEMBERS FOR FLEXURE & SHEAR | 130 |
| C5.1 Scope | 130 |
| C5.2 Design of Members for Flexure | 130 |
| C5.2.2 Nominal Strength of Members due to Material Rupture | 131 |
| C5.2.3 Nominal Strength of Members due to Local Instability | 131 |
| C5.2.4 Nominal Strength of Members due to Lateral-Torsional Buckling | 132 |
| C5.3 Design of Members for Shear | 133 |
| C5.3.3 Resistance of Members to Web Shear Buckling | 133 |
| C5.4 Design of Members for Concentrated Forces | 134 |
| C5.4.1 Design Basis | 134 |
| C5.4.3 Nominal Strength of Members due to Web Crippling | 134 |
| C5.4.4 Nominal Strength of Members due to Web Compression Buckling | 134 |
| C5.5 Design for Copes, Notches, Holes and Openings | 135 |
| C5.5.1 Copes, Notches, Holes and Web Openings in the Flange or Web | 135 |
| C5.6 Design of Flexural Members for Serviceability | 135 |
| References | 136 |

| | |
|--|----------------|
| C6. DESIGN OF MEMBERS UNDER COMBINED FORCES & TORSION | 139 |
| C6.1 Scope | 139 |
| C6.2 Symmetric Members Subject to Bending and Axial Load | 139 |
| C6.3 Doubly Symmetric Members under Torsion and Combined Torsion, Flexure and/or Axial Force | 139 |
| C6.3.1 Torsional Strength of Circular and Rectangular Hollow Tubes | 139 |
| C6.3.2 Rectangular Hollow Tubes Subject to Combined Torsion, Flexure and Axial Force | 141 |
| C6.3.3 Design Strength of Open Doubly Symmetric Shapes Subject to Torsion and Combined Forces | 141 |
| References | 142 |
| C7. DESIGN OF PLATES AND BUILT-UP MEMBERS | 143 |
| C7.1 Scope | 143 |
| C7.2 General Provisions | 143 |
| C7.3 Design of Plates Subjected to Flexure | 147 |
| C7.3.1 Nominal Flexural Strength of Plates for One-Way Plate Bending | 147 |
| C7.3.2 Nominal Flexural Strength of Plates for Two-Way Plate Bending | 147 |
| C7.4 Design of Plates Subjected to Through-the-Thickness Shear | 147 |
| C7.4.1 Nominal Shear Strength of Plates for One-Way Plate Bending | 147 |
| C7.4.3 Pull-Through Strength of Plates | 148 |
| C7.5 Design of Plates Subjected to In-Plane Tensile Loading | 149 |
| C7.5.1 Nominal Tensile Strength of Plates | 149 |
| C7.6 Design of Plates Subjected to In-Plane Compressive Loading | 151 |
| C7.6.1 Nominal Compressive Strength of Plates | 151 |
| C7.6.3 Nominal Strength of Plates Subjected to Longitudinal Compression | 151 |
| C7.6.4 Nominal Strength of Plates Subjected to Combined Longitudinal and Transverse Compression | 152 |
| C7.7 Design of Plates Subjected to In-Plane Shear Loading | 152 |
| C7.7.1 Nominal In-Plane Shear Strength of Plates | 152 |
| C7.7.2 Nominal Material Rupture Strength of Plates Subjected to In-Plane Shear | 152 |
| C7.7.3 Nominal Buckling Strength of Plates Subjected to In-Plane Shear | 153 |
| C7.8 Design of Built-up Members | 154 |
| C7.8.1 Design Basis | 154 |
| C7.8.2 Design of Built-up Members Subjected to In-Plane Tensile Loading | 154 |
| C7.8.3 Design of Built-up Members Subjected to In-Plane Compressive Loading | 154 |
| C7.8.4 Design of Built-up Members Subjected to Through-the-Thickness Shear | 154 |
| C7.8.5 Design of Panel-Based Assemblies | 155 |
| C7.8.6 Design of Plate Girders | 158 |
| C7.8.7 Design of Shear Walls and Diaphragms | 159 |
| C7.9 Design of Decking Members | 160 |
| C7.9.1 Design Basis | 160 |
| C7.10 Design of Plates for Serviceability | 160 |
| C7.11 References | 160 |
| C8. DESIGN OF BOLTED CONNECTIONS | 162 |
| C8.1 Scope | 162 |
| C8.1.1 Axially Loaded Connection Types | 163 |

| | |
|--|-----|
| C8.1.2 Placement of Bolts | 164 |
| C8.1.3 Framing Connections | 164 |
| C8.2 General Provisions | 165 |
| C8.2.1 Scope | 165 |
| C8.2.2 Bolts | 165 |
| C8.2.3 Size and Use of Bolt Holes | 166 |
| C8.2.4 Nuts and Washers | 167 |
| C8.2.5 Connection Geometry Requirements | 167 |
| C8.3 Connection Design | 170 |
| C8.3.1 Scope | 170 |
| C8.3.2 Nominal Strength of Single Row Bolted Connections | 171 |
| C8.3.3 Design Resistance of Multi-bolted Connections | 178 |
| C8.3.4 Frame Connections | 183 |
| References | 185 |

LIST OF TABLES

| | Page |
|--|------|
| Table C2.3-1 Resistance factors, ϕ , required to achieve target reliability, β , for general buckling of pultruded I-shaped section | 104 |
| Table C2.3-2 Reliability index goals for LRFD of pultruded FRP structures | 105 |
| Table C2.3-3. Summary of resistance factors to be applied to nominal resistance, defined as the 5-percent exclusion limit, in key limit states | 106 |
| Table C5.1 Values for C_b for Simply Supported Beams Laterally Braced on Each End | 133 |
| Table C5.2 Values for $f_1(z)$ and $f_2(z)$ in Equation C5.6-1 | 136 |
| Table C7.2-1 Material Failure Modes and Test Methods for Pultruded Plates | 145 |

LIST OF FIGURES

| | |
|---|-----|
| Figure C1.4-1 Frequency distribution of safety margin, Z , defining reliability index, β | 97 |
| Figure C4.4.1 Experimental vs. predicted strength values of axially compressed pultruded I-shaped sections | 125 |
| Figure C4.4.2 Experimental vs. computed strength values of axially compressed T-shaped pultruded members | 126 |
| Figure C.4.4.3 Experimental vs. predicted strength values of axially compressed single angle sections with equal legs | 127 |
| Figure C4.4.5 Experimental vs. predicted strength values of axially compressed square box pultruded sections | 128 |
| Figure C5.14 – Effective web compression buckling length, l_{eff} | 134 |
| Figure C7.2-1 Principal Material Directions for Pultruded Plates | 144 |
| Figure C7.2-2 Shear Planes for In-plane Shear Loading | 146 |
| Figure C7.2-3 Shear Plane for Through-the-Thickness Shear Loading Perpendicular to the Material Longitudinal Direction | 146 |
| Figure C7.2-4 Shear Plane for Through-the-Thickness Shear Loading Perpendicular to the Material Transverse Direction | 146 |
| Figure C7.4.1-1 Pultruded Plate V-Notched Beam Specimen for Through-the-Thickness Shear Strength, F_L^v , according to ASTM D5379 | 148 |

| | |
|--|-----|
| Figure C7.4.1-2 Pultruded Plate V-Notched Beam Specimen for Through-the-Thickness Shear Strength, F_T^v , according to ASTM D5379 | 148 |
| Figure C7.5.1-1 Open-Hole Tensile Strength Reduction Factor in the Longitudinal Direction (Lopez-Anido 2009) | 150 |
| Figure C7.5.1-2 Open-Hole Tensile Strength Reduction Factor in the Transverse Direction (Lopez-Anido 2009) | 150 |
| Figure C7.7.2-1 Pultruded Plate V-Notched Beam Specimens for In-Plane Shear Strength, F_{LT} , according to ASTM D5379 | 153 |
| Figure C7.7.3-1 In-plane Shear Loading | 153 |
| Figure C7.8.5-1 Schematics of Connections in Panel-Based Assemblies Cross-Sections | 156 |
| Figure C7.8.5.1-1 Panel-based Assembly with Webs Parallel to the Plate Material Longitudinal Direction Attached to One Face | 157 |
| Figure C7.8.5.1-2 Panel-based Assembly with Webs Parallel to the Plate Material Transverse Direction Attached to One Face | 157 |
| Figure C7.8.5.2-1 Schematics of Panel-based Assemblies with Plates and Parallel Webs Attached in Between the Plates | 158 |
| Figure C7.8.6 Schematics of Connections in Plate Girders | 159 |
| Figure C8.1. Notation and definitions for the connection geometry | 168 |
| Figure C8.2. Definition for unloaded edge and unloaded end | 168 |
| Figure C8.3. Bolted connection distinct modes of failure and simplified stress distributions (a) bolt failure, (b) through-the-thickness tension, (c) bearing, (d) net tension, (e) shear-out, (f) cleavage, (g) net tension ‘splitting’, when unloaded edges are not nearby, and (h) block shear. | 169 |
| Figure C8.4 Connection force cases when the connection resistances of R_{sh} and R_{cl} need not be determined. | 172 |
| Figure C8.5. Ratio of experimental strength to predicted strength using strength formulae in Section 8.3.2 for single bolted connections and the 22 test results from Rosner and Rizkalla (1995) | 173 |
| Figure C8.6. Variation of pin-bearing strength, F_{θ}^{br} , with orientation of a FRP material (Ascione <i>et al.</i> , 2009). | 175 |
| Figure C8.7. Form of closed section connection detailing when the characteristic pin-bearing strength in Equation 8.3.2-5 is to be reduce by a factor of 0.5 to account for bolt flexure | 176 |

| | |
|--|-----|
| Figure C8.8. Illustrations of different connection configurations for how distances e_3 and e_4 are to be defined when the bolted connection has a single row of bolts. | 178 |
| Figure C8.9. Ratios of experimental strength with predict net tension strength for multi-row bolted connections using the longitudinal test data from Hassan <i>et al.</i> (1997) and Rosner and Rizkalla (1995) and the design formulae in Section 8.3.3. | 180 |
| Figure 8.10. Ratios of experimental strength with predict net tension strength for multi-row bolted connections using the transverse test data from Hassan <i>et al.</i> (1997) and Rosner and Rizkalla (1995) and the design formulae in Section 8.3.3. | 181 |
| Figure C8.11. Illustrations of different connection configurations for how distances e_3 and e_4 are to be defined when the bolted connection has two or three rows of bolts. | 182 |
| Figure C8.12. Block shear loading situations with assumed direct stress distributions | 183 |
| Figure C8.13. Area resisting shear force in clip angle for simple connection. | 185 |

C1. GENERAL PROVISIONS

C1.1 Scope

C1.1.1 Applicability and Exclusions.

This *Standard* is limited in its applicability to pultruded fiber-reinforced polymer (FRP) composite shapes that utilize glass fiber reinforcement. The provisions were developed to be applicable to buildings and other structures; thus, the scope of the provisions is similar to the scope of *ASCE Standard 7, Minimum design loads for buildings and other structures* (ASCE, 2010).

FRP structural systems and components may be highly sensitive to their service environments. The Engineer is advised to ascertain that the provisions and material constants herein are applicable to the structural component or system under consideration.

The design strength and stiffness values provided in this *Standard* apply to new structural products that are being placed in service for the first time. The *Standard* provisions may not be applicable for structural products that may have been put in service prior to its approval by ASCE. This restriction stems from the difficulty of knowing the grade of material and the quality assurance procedures in effect at the time of manufacture and the potential that the material has sustained significant but hidden damage due to aggressive service and environmental conditions.

C1.1.2 Maximum Service Temperature.

The effect of temperature on strength and deformation of pultruded FRP shapes may be significant (Zureick and Kahn, 2001; Engindeniz and Zureick, 2008). Accordingly, the glass transition temperature for the composite system must be at least 40°F (22°C) above the maximum expected service temperature of the structural system. The glass transition temperature, T_g , is the approximate temperature value above which the matrix changes from a glassy to a rubbery state and the mechanical properties degrade.

C1.1.3 Units.

Equations in this standard that are unit-dependent, as a consequence of embedded unit-dependent constants, are presented in the U.S. customary units. Many of the equations in this standard do not require explicit statement of units. They only require that the user apply the equations consistently. Tables containing unit-dependent constants are presented with the SI conversion factors in footnotes.

C1.2 Referenced Specifications, Codes and Standards

The references listed in Section 1.2 of the *Standard* provide essential support to the Engineer of Record in discharging his/her professional responsibilities in the design of pultruded FRP composite structural components and systems in buildings and other structures.

C1.3 Materials

A major advantage of pultruded FRP composite structural components is that they can be engineered to achieve specific structural performance objectives efficiently and at reasonable cost. The general requirements in Section 1.3 for constituent materials (fiber system and matrix), mechanical properties for structural members, durability and environmental effects, and impact tolerance establish a minimum level of performance for pultruded FRP members and systems intended for use in engineered civil structural systems. The necessary material performance requirements for a particular structural system should be determined following discussion between the Engineer and manufacturer.

Standards developed by ASTM International (formerly the American Society for Testing and Materials) are the basic source for engineering properties in this *Standard*. Pultruded FRP composite members and components are engineered to be orthotropic in nature to take full advantage of the material in meeting structural performance objectives. Among their important material properties are density, hardness, glass transition temperature, and strength in tension and compression. Important mechanical (engineering) properties include longitudinal and transverse strength, elastic modulus in tension and compression and in-plane shear strength and modulus. Some structural engineering properties that are determined from alternative ASTM tests (e.g., member vs coupon tests) may differ considerably because these test methods were developed at different times for different purposes and utilize different specimens. The Engineer is advised to examine the technical basis for the reference strength or stiffness provided by the manufacturer as part of the structural design process.

C1.3.1 FRP Constituent Materials

(a) Fiber system. The presence of fibers in multiple directions ensures minimum strengths under multi-directional loading, increases the bearing strength when the connection is subjected to bearing forces, and minimizes the potential of rupture or shear in a structural connection. Symmetrical and balanced reinforcing stacking systems avoid design and fabrication issues associated with coupling between bending, twisting and stretching. The minimum requirements for reinforcement ensure adequate strength and stiffness for general structural engineering purposes. The minimum tensile strength value of 290 ksi (2,000 MPa) leads to a tensile modulus of approximately 10,000 ksi (69 GPa)

(b) Matrix. FRP pultruded composite shapes addressed by this standard can be fabricated using any thermoset resin. Additives to the resin system that influence processing, such as fillers, promoters, accelerators, inhibitors, UV agents, and pigments should be compatible with the fiber and resin system.

C1.3.2 Physical and Mechanical Properties of Pultruded FRP Products

The physical properties in Table 1.3-1 and characteristic mechanical (engineering) properties for shapes and plates in Tables 1.3-2(a) and 1.3-2(b) establish minimum strength and stiffness requirements for structural engineering applications, regardless of which FRP material system is selected, and are developed from test specimens that represent the structural product in its reference condition. There is no intention that structural design should necessarily utilize these minimum requirements; engineering parameters tabulated in manufacturers' literature for pultruded FRP shapes and plates to allow for differences in fiber form or orientation may exceed the minimum values in these tables.

C1.3.3 Fire, Smoke and Toxicity

In addition to the destruction of the matrix, most resin systems emit toxic smoke under fire conditions. The Engineer of Record is cautioned to design pultruded FRP structural components and systems to conform to the requirements of the applicable building code.

C1.3.4 Durability and Environmental Effects.

Pultruded FRP structural components and systems are sensitive to the effects of moisture, temperature, ultraviolet, chemical attack and other environmental effects that may lead to deterioration in structural strength and stiffness during the service life of the structure. Ultraviolet embrittles the matrix and may cause loss of tensile strength in glass fibers; UV is best dealt with using surface coatings (veils) with UV inhibitors, which reduce the long-term effects of UV radiation and can enhance the aesthetics of the system. Acids and alkalis may have a deleterious effect on the matrix. The effects of alkalinity on FRP composites depend on the chemical characteristics of the exposure and the material system. The Engineer is advised to give these issues careful attention in structural design.

C1.4 Design basis

C1.4.1 Limit States Design.

A structural component or system reaches a limit state when it ceases to fulfill its intended purpose in some way. Two general types of limit states apply for building structures: ultimate limit states and serviceability limit states. Ultimate limit states relate to requirements for safety under extreme load conditions, and include rupture, crushing, instability, and overall loss of equilibrium. Codes and specifications historically have emphasized the ultimate limit states because of their paramount importance to public safety. Serviceability limit states relate to functional requirements under ordinary or service conditions, and include unacceptable deformations and vibrations. Limit states vary from member to member and several limit states may have to be considered to achieve a satisfactory design. Chapters 3 through 8 in this *Standard* are organized around the dominant ultimate limit states expected to govern design of pultruded FRP structural members, components and systems.

FRP composite structures traditionally have been designed using the allowable stress design (ASD) method. In ASD, the elastically computed stresses due to unfactored nominal (or working) loads are limited so as not to exceed an *allowable* stress, defined as a limiting stress (i.e., stress at which rupture occurs in tension, flexure or shear, or buckling occurs in compression) divided by a factor of safety. That factor of safety has been chosen by subjective judgment, based on perceptions of uncertainty and failure consequences, and typically has ranged from about 1.7 to 3.0 for members and connections using common construction materials. Serviceability concerns have been reflected indirectly in limits on static deflections or span-to-depth ratios in flexural members; such limits are aimed at ensuring a minimum level of stiffness. By keeping stresses low and elastic throughout the structure, the allowable stress criteria not only ensured safety but indirectly took care of many serviceability problems as well. Research in modern design and construction practices has exposed a number of shortcomings of ASD (Ellingwood et al, 1982; Galambos et al., 1982). In the past two decades, modern codes and standards worldwide almost universally have adopted the concepts of probability-based limit states design (PBLSD). PBLSD, with its explicit consideration of structural behavior and sources of uncertainty due to strength, loads and modeling, permits code writers and designers to closely

relate loads, material properties and behavior to the performance objectives of a building structure (Ellingwood, 1994). The Load and Resistance Factor Design (LRFD) format is one particular form of probability-based limit states design, and has been adopted for most standards and specifications in the United States.

C1.4.2 General Analysis Requirements

The forces or moments due to factored loads acting upon structural members and connections are determined by structural analysis for appropriate factored load combinations in Sec. 1.5.2. Elastic analysis is permitted unconditionally by this *Standard*. It is permitted to consider nonlinear behavior of components and systems, provided that substantiating data on their behavior is available and approved by the authority having jurisdiction. If the relationship between loads and structural response is nonlinear, load factors should be applied to nominal loads prior to performing the structural analysis.

Load patterns or combinations that produce critical forces may not be the same in all members. The designer is advised to take these differences into account in determining the forces due to factored loads.

The longitudinal modulus of elasticity, E_L , and shear modulus, G_{LT} , used in structural analysis and design are adjusted for end-use conditions, but the time effect factor (TEF) is not applied because the TEF appears in the expression for design strength. Load effects (forces, moments and deflections) in indeterminate structures should be determined using the *adjusted mean values* of these moduli.

C1.4.3 Design for Strength

Conformance with the requirements for strength in this *Standard* normally will be demonstrated by engineering analysis. In situations where this is not feasible or possible, the Engineer is permitted to demonstrate conformance with intent of the *Standard* by prototype testing.

In LRFD, satisfaction of the basic requirement for safety,

$$\text{Design strength} > \text{Required strength} \quad (\text{C1.4-1})$$

is measured in terms of a desired probabilistic measure of reliability, as described subsequently. This requirement is transformed to a set of conventional safety checking equations (Ellingwood et al., 1982) by the code developers so that the end product has a conventional appearance and the designer need not deal with the complexities of reliability analysis. For strength design, Eq C1.4-1 is expressed as:

$$\phi R_n > \sum \gamma_i Q_i \quad (\text{C1.4-2})$$

in which R_n = nominal value of resistance computed using stipulated formulas based on principles of structural mechanics, ϕ = overall resistance (or capacity reduction) factor on structural action, and the right-hand side of the equation represents the required strength, determined by structural analysis using the load requirements in *ASCE Standard 7-10*. The load and resistance factors take into account the uncertainties that are inherent in structural loads, in the material strengths, geometry and fabrication of structural components, and in the analysis model. They cannot account for gross error or negligence; hence, the importance of the

requirements for quality assurance and control in Section 1.7 of this *Standard*. The advantage of LRFD over ASD is at least twofold: (1) The use of multiple load and resistance factors better accounts for the different levels of uncertainty in these variables than one overall safety factor, and (2) the probabilistic basis provides more controllable and uniform reliability for structural components and systems within the scope of the *Standard* than can be achieved with safety factors that have been determined judgmentally.

The conceptual basis for probability-based LRFD is founded in classical structural reliability theory. In the simplest model, the structural action due to the combined loads, Q , and the structural resistance, R , are both modeled as random variables. The limit state is entered if $R < Q$; hence, the limit state probability

$$P_f = \int F_R(x) f_Q(x) dx \quad (C1.4-3)$$

provides a quantitative measure of the likelihood of unsatisfactory structural performance. The uncertainties in the resistance and combined load effect are modeled by the cumulative distribution function of resistance, $F_R(x)$ and the probability density function, $f_Q(x)$,¹ of the combined load, Q . In probability-based design, the structural members and connections are proportioned so that the limit state probability is less than a target value set by regulatory authority, or $P_f < P_{f,target}$.

While Equation C1.4-3 provides the conceptual basis for PBLSD, it is difficult to work with in practical structural design situations. First-order (FO) reliability methods have evolved to address these difficulties (Ellingwood, 1994). The limit state $R < Q$ can be reformulated in terms of a margin of safety, Z :

$$Z = R - Q < 0 \quad (C1.4-4)$$

in which Z is a random variable that is dependent on R and Q . This margin is illustrated in Figure C1.4-1.

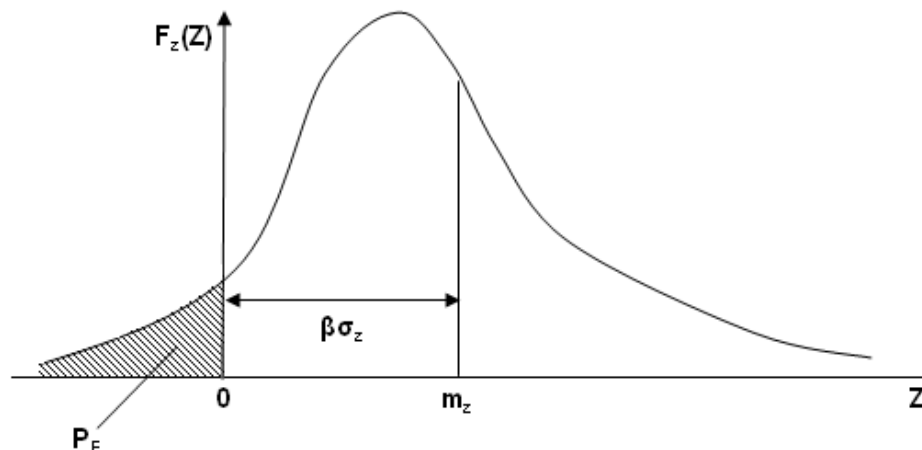

Figure C1.4-1. Frequency distribution of safety margin, Z , defining reliability index, β

¹ The cumulative distribution function and probability density function are alternate means for describing a random variable and the uncertainty that it represents. The density function is analogous to the more familiar *relative frequency* diagram or histogram. The distribution function defines the probability that a random variable, R , is less or equal to a number, x .

The uncertainty in Z is represented by the dispersion in the frequency distribution around the mean value, m_Z ; this dispersion is measured by its standard deviation, σ_Z , or its coefficient of variation (COV). The limit state probability, P_f , is the probability that Z is less than 0, represented by the shaded area in the figure. Provided that the probability laws of R and Q are known, the performance requirement $P_f < P_{f,target}$ can be restated as $m_Z > \beta\sigma_Z$. The parameter β is denoted the *reliability index*, and plays a central role as a measure of reliability in LRFD. For well-behaved limit state functions (i.e., those not involving bifurcation of equilibrium or large material nonlinearities), the limit state probability is formally related to the reliability index by $P_f = \Phi(-\beta)$, in which $\Phi(\cdot)$ = standard normal probability integral. Further details on FO reliability analysis are available in the literature (e.g., Melchers, 1999).

With the reliability framework above and probabilistic models of load and resistance available, load and resistance factors in Equation C1.4-2 for practical structural design can be selected through an optimization process to achieve the target reliability objectives of the standard or specification (Ellingwood, et al, 1982). This methodology forms the basis for the load combination requirements in *ASCE Standard 7-10* and for the LRFD strength criteria for various steels (AISC, 2010; AISI, 2007; ASCE 2008) and for engineered wood construction (ASCE, 1994; ANSI/AF&PA 2005).

C1.4.4 Design for Serviceability

This general performance requirement is consistent with the language in Section 1.3 of *ASCE Standard 7-10*. Serviceability limit states relate to functional requirements of the building under ordinary service conditions. Excessive deformations that are unsightly or that lead to nonstructural damage or excessive structural motions that cause discomfort to building occupants are examples of serviceability limit states. Serviceability criteria to guard against such limit states are an essential design consideration with any light-frame construction technology, where limits on elastic deflection or vibration, rather than strength, frequently control member proportions.

C1.5 Loads and Load Combinations

The nominal loads, load combinations, and load factors in Section 1.5 are taken directly from *ASCE Standard 7-10, Minimum Design Loads for Buildings and Other Structures*. These load requirements are suitable for design of buildings and similar structures constructed with all materials of construction, including FRP pultruded structures. They do not apply to vehicle loads on bridges, construction loads, and other loads that are outside the scope of *ASCE Standard 7-10*.

C1.5.1 Nominal Loads

The nominal loads that appear in Sec. 2 through 8 and 10 through 13 of *ASCE Standard 7-10* account for the fact that structural loads are random in nature by specifying the nominal load for design at a conservative fractile of the load distribution, wherever possible. For occupancy live load, snow and rain loads, the nominal load for ordinary building design is specified at a probability of approximately 2% of being exceeded in any year (equivalently, a mean return period of 50 years). The design load equals the nominal load multiplied by a load factor. The wind load provisions in *ASCE Standard 7-10* now specify the wind speeds at a return period of approximately 700 years (annual probability of approximately 0.0014) for ordinary buildings, and

the load factor on wind load equals 1.0. For earthquake load, the design earthquake, specified as two-thirds the maximum considered earthquake, has a probability of approximately 0.002 of being exceeded in any year in high-seismic regions of the U.S. with the exception of near-fault regions (equivalently, a return period of approximately 500 years), with an associated load factor equal to 1.0.

In contrast to dead, live, wind and snow loads, the effects of which are primarily static on low-rise buildings, earthquakes cause forces that fluctuate rapidly in time. The earthquake load provisions in *ASCE Standard 7-10* have been developed to take advantage of inelastic behavior and resulting energy dissipation that is possible in well-integrated structural systems subjected to dynamic effects. However, certain detailing requirements must be followed to achieve the expected level of performance reflected in the response modification factor, R , system over-strength factor, Ω_o , and deflection amplification factor, C_d , that are stipulated in Section 12.2 of *ASCE Standard 7-10* and are used to determine design forces and deformations. In situations where structural system response is essentially elastic, these factors should be set equal to 1.0.

C1.5.2 Load Combinations for Strength Limit States

The load combinations for the strength limit states in *ASCE Standard 7-10* were developed using principles of structural reliability theory and probabilistic load modeling, in a program to unify the structural design process by providing common load requirements for limit states design involving different construction materials (Galambos et al., 1982; Ellingwood et al., 1982). The load factors reflect the uncertainty in the determination of the various loads.

Design for strength limit states requires that the structural components and system sustain the maximum combined load effect that may occur during a period of reference, taken for convenience as 50 years. Structural loads (other than dead load) vary in time, but their maximum values generally are not attained simultaneously; rather, the maximum effect of a combination of loads generally occurs when one of the loads attains its maximum value during the reference period while the other loads assume their point-in-time values (Turkstra and Madsen, 1980). Modern load combination analysis deals with this fact using a “principal action-companion action” format. In Section 1.5.2, the loads with load factors greater than or equal to 1.0 (e.g., 1.6L, 1.0W, 1.6S and 1.0E) represent the principal action in the respective combinations. Combinations 1.5-6 and 1.5-7 cover situations in which the stabilizing effect of gravity dead load may not be adequate to counter lateral or uplift forces; in that case, the dead load is assigned a factor 0.9. Such effects may occur when lateral forces due to wind or earthquake may cause force reversals in columns, walls or foundation anchorages or when wind effects lead to uplift forces on roofs. Such effects may be particularly significant in light-frame construction, where the gravity loads are relatively small. The Engineer should give this problem due consideration in design.

Other loads not traditionally covered by *ASCE Standard 7-10* may require consideration in design. Statistical data on these loads are limited and the procedures used to derive the load requirements in Sec. 1.5.1 and 1.5.2 cannot be applied. The Engineer is advised to give such loads careful consideration.

C1.5.3 Load Combinations for Serviceability Limit States.

Design for excessive static deflections or drifts normally should be performed using service rather than design loads. Service loads seldom exceed the nominal loads, and often may be less,

depending on the circumstances. The serviceability load combinations are distinguished by whether the serviceability limit state is transient or permanent. Load combinations 1.5-8 through 1.5-10 ensure that the probability of exceeding the stipulated load effect is on the order of approximately 0.05 – 0.10/year.

C1.6 Structural Design Drawings and Specifications

Unlike steel, reinforced concrete, masonry and timber construction, there is limited experience with FRP pultruded structural shapes in civil building design and construction. This provision summarizes the minimum requirements for effective communication between the structural engineer and the fabricator.

C1.7 Fabrication, Construction and Quality Assurance

The provisions in this section establish minimum requirements for quality assurance and control in fabrication and construction of FRP pultruded structural components and systems. Similar requirements exist for other construction materials, e.g., the *Code of Standard Practice* promulgated by the American Institute of Steel Construction.

Standard installation operations incorporate the modification of minor misfits by reasonable amounts of cutting, drilling, or reaming and the drawing of elements into alignment with drift pins.

References-Commentary Section 1

AF&PA/ASCE (1996). LRFD for Engineered Wood Construction (*AF&PA/ASCE Standard 16-95*). American Society of Civil Engineers, Reston, VA.

AISC (2010). *Specification for Structural Steel Buildings*. American Institute of Steel Construction, Inc., Chicago, IL.

AISI/CSA/CANACERO (2007), *North American specification for the design of cold-formed steel structural members (AISI S100-07, CSA S136-07)*, American Iron and Steel Institute, Washington, DC.

ANSI/AF&PA NDS-2005 National Design Specification for Wood Construction. American Forest and Paper Association Washington, DC.

ASCE (2010). *Minimum Design Loads for Buildings and Other Structures (ASCE Standard 7-10)*. American Society of Civil Engineers, Reston, VA.

ASCE (2008). *Specification for the design of cold-formed stainless steel structural members (SEI/ASCE Standard 8-02)*, American Society of Civil Engineers, Reston, VA.

Building Seismic Safety Council (2006). NEHRP Recommended Provisions for the Development of Seismic Regulations for New Buildings. *Report FEMA 450/451*(two volumes), Federal Emergency Management Agency, Washington, DC.

Ellingwood, B., MacGregor, J.G., Galambos, T.V, and Cornell, C.A. (1982). Probability Based Load Criteria: Load Factors and Load Combinations. *J. Struct. Div., ASCE* 108(5):978-997.

Ellingwood, B. and Redfield, R. 1983. Ground Snow Loads for Structural Design. *J. Str. Engrg., ASCE* 109(4):950-964. New York, NY.

Ellingwood, B. (1994). Probability-based codified design: past accomplishments and future challenges. *Struct. Safety* 13(3):159-176.

Ellingwood, B.R.. (2003), Toward load and resistance factor design for fiber-reinforced polymer (FRP) composite structures. *J. Struct. Engrg. ASCE* 129(4): 449-458.

Ellingwood, B. and Rosowsky, D. 1991. Duration of Load Effects in LRFD for Wood Construction. *J. Struct. Engrg., ASCE* 117(2):584-599. New York, NY.

Engindinez, M. and Zureick, A.-H. (2008). Deflection response of glass fiber-reinforced pultruded components in hot weather climates. *J. Composites for Const. ASCE* 12(3):355-363.

Galambos, T.V, Ellingwood, B., MacGregor, J.G., and Cornell, C.A. 1982. Probability Based Load Criteria: Assessment of Current Design Practice. *J. Struct. Div., ASCE* 108(5):959-976.

ICC (2006). *International Building Code (IBC) 2006 edition*. International Code Council, Falls Church, VA.

Melchers, R.E. (1999). *Structural reliability: analysis and prediction*. John Wiley, Chichester, UK.

Turkstra, C. and Madsen, H. 1980. Load Combinations in Codified Structural Design. *J. Struct. Div., ASCE* 106(12):2527-2543. New York, NY.

Zureick, A.-H. and Kahn, L. (2001). Rehabilitation of reinforced concrete structures using fiber-reinforced polymer composites. *ASM Handbook 21*, ASM Int., 906-913.

C2. DESIGN REQUIREMENTS

C2.3 Design Strength

The design strength in this *Standard* is the product of a nominal resistance in the end-use condition, a resistance factor which is dependent on the limit state, and a time effect factor (TEF), which is dependent on the principal load in the load combination that governs design. This format has been used successfully in *ASCE Standard 16-95* (1996) governing design for engineered wood construction. These terms have been derived to be compatible with the loads and load combinations for limit states design that appear in Sec. 2.3 of *ASCE Standard 7-10* and a level of performance that is consistent with the performance of competing structural materials. These design criteria are not applicable to design of FRP pultruded structures using load requirements that differ from those in *ASCE Standard 7-10*.

The *Standard* requires that the design strength for limit states involving stability considerations be determined using the *adjusted 5th percentile values* of elastic and shear moduli. For typical coefficients of variation in modulus, the 5th percentile is approximately 84% to 92% of the mean value.

C2.3.1 Basic Strength Requirement

Resistance criteria for LRFD must be selected to achieve the target reliability objectives of the standard when used with the load requirements of Section 1.5. Reliability benchmarks for other common construction materials designed by LRFD methods (AF&PA/ASCE, 1996, ANSI/AF&PA, 2005; AISC, 2005; AISI, 2007; ASCE, 2005, 2008; AISC, 2007) have been established through an assessment of structural members and connections for which traditional design practices have led to acceptable performance. As an example of how this has been done, the structural design of a simple steel tension member for dead and live load by traditional ASD methods is governed by either yielding on the gross section or rupture on the net-section:

$$\text{Yield: } 0.6 F_y A_g > D_n + L_n \quad (\text{C2.3-1})^1$$

$$\text{Rupture: } 0.5 F_u A_e > D_n + L_n \quad (\text{C2.3-2})$$

in which D_n and L_n are tension forces due to *ASCE 7-10* dead and live load, F_y and F_u are nominal yield and ultimate strength, and A_g and A_e are gross and effective net areas, respectively. Using representative statistics for load and resistance (Galambos, et al, 1982), the reliability index for the yield limit state varies from about 3.4 when $L_n/D_n = 1$ to about 2.4 when $L_n/D_n = 4$; for rupture, it varies from about 3.8 for $L_n/D_n = 1$ to 3.2 for $L_n/D_n = 4$. The decrease in β with L_n/D_n occurs because the variability in live load is larger than the variability in dead load, and one overall factor of safety (1.67 for yield; 2 for rupture) is insufficient to ensure constant reliability for different combinations of these loads. It should be emphasized that a constant factor of safety does not ensure a constant reliability.

¹ A distinction is made in C2.3.1 between the nominal resistance and load terms (e.g., R_n , D_n or L_n), denoted with a subscript “n”, and the random resistance and loads (R, D or L) for clarity in explanation of the provisions. This distinction is not necessary in the Standard, where the load and resistance criteria do not involve random variables.

Structural design of the same steel tension member for dead and live load using LRFD is governed by:

$$\text{Yield: } 0.9 F_y A_g > 1.2 D_n + 1.6 L_n \quad (\text{C2.3-3})$$

$$\text{Rupture: } 0.75 F_u A_e > 1.2 D_n + 1.6 L_n \quad (\text{C2.3-4})$$

The reliability indices associated with the yield and rupture limit states for tension members designed by these criteria are about 2.7 and 3.5, respectively, and are virtually independent of L/D.

Similar analyses have been performed for other limit states and construction materials (Galambos, et al, 1982; Ellingwood, et al, 1982; Ellingwood, 2003). In the current generation of LRFD standards and specifications, β is typically 2.5 – 3.0 for structural members in which the failure mode is relatively benign and does not endanger the structural system as a whole. The reliability indices for LRFD of connections are higher – on the order of 4.0 to 4.5 - because connection failures tend to be more sudden than member failures, and the cost of the connection is determined mainly by the labor in its fabrication rather than cost of materials. During the past two decades, structural engineers in the United States and Canada have become accustomed to such reliability measures.

Development of resistance factors (ϕ) for pultruded FRP shapes

The development of reliability-based design criteria for pultruded FRP structures, beginning with an evaluation of reliabilities associated with traditional acceptable design practices, followed by the selection of ϕ -factors based on target β 's, as described in Section C1.4.3 for other construction materials, is problematic. Unlike other common construction materials, experience with FRP structural components in civil construction is limited and existing criteria have not undergone review by a broad-spectrum professional committee and been approved through the voluntary consensus standard process. Accordingly, the LRFD criteria for pultruded FRP composite structures in this *Standard* are intended to achieve levels of safety and serviceability that are comparable to those of other building products against which they may compete.

Engineered construction with FRP pultruded structures involves a wide range of producers and product types. The specified value of R_n for a structural component must depend on product line in order to maintain the code objective of a consistent reliability index. To facilitate standardization and to make the *Standard* usable across a wide a range of FRP pultruded building products, one basic set of ϕ -factors was selected to reflect in a general way the relative variability in strength and differences in failure modes and consequences of each limit state. Further adjustments to account for differences in product end-use conditions are built into the reference resistance, R_o , of the building product supplied by the manufacturer (Section 2.4.1).

To illustrate the selection of ϕ for a common limit state, consider a simple pin-ended I-shaped pultruded column supporting a floor system with a nominal live load of 40 psf (1.9 kPa) and a nominal dead load of 10 psf (0.48 kPa). Assume that local buckling is precluded and no adjustment for time effects or other end-use conditions is necessary ($\lambda = 1.0$). The LRFD design requirement for the column is (cf Eq. 2.3-1),

$$\phi F_{cr,n} A_{gn} \geq 1.2 D_n + 1.6 L_n \quad (\text{C2.3-5})$$

in which A_{gn} = nominal (handbook) gross section area, $F_{cr,n}$ = nominal value of critical stress, determined at the 5th percentile of the distribution of the critical stress for reasons explained subsequently (Eq. 4.4-2, Section 4), D_n and L_n represent the mid-span moments due to the *ASCE 7-10* nominal dead and live load, and ϕ = resistance factor. The general buckling limit state under the conditions noted above is defined by,

$$B F_{cr} A_{gn} - (D + L) = 0 \quad (C2.3-6)$$

in which B = bias (or professional) factor, describing factors not covered by the analytical model of strength, F_{cr} critical buckling stress for a static rate of load and D and L are random dead and live load moments at mid-span. Substituting A_{gn} determined from eq C2.3-5 into C2.3-6, one obtains,

$$B M F [(1.2 + 1.6 \theta_n) / \phi] - D/D_n - L_n/D_n \cdot L/L_n = 0 \quad (C2.3-7)$$

in which $\theta_n = L_n/D_n$, $M = F_{cr} / F_{cr,n}$, $F = A/A_{gn}$. To complete the reliability analysis, probabilistic models of M , F and B are required [probabilistic models for D/D_n and L/L_n have been determined previously (Galambos, et al, 1982)]. If F_{cr} is modeled by a Weibull distribution (Ellingwood, 2003; Zureick, et al, 2006) and $F_{cr,n}$ is stipulated as the 5-percentile of that distribution, the statistics of M depend on the coefficient of variation on F_{cr} , which reflects the quality control in manufacture of the pultruded material. The fabrication factor is described by a normal distribution, with mean and coefficient of variation 1.0 and 0.05, respectively. The bias factor, B , is determined by statistical analysis of the ratio of test-to-calculated column strengths, when the calculated values are determined from Eq (4.4-2), with all parameters in that predictive equation determined from companion specimen tests. The results of such an analysis reveal that B can be described by a normal distribution, with mean and coefficient of variation of 0.98 and 0.11, respectively. Similar data are available in the literature for other limit states and structural members (e.g., Wang and Zureick, 1997; Zureick and Scott, 1997; Zureick and Steffen, 2000). Using Monte Carlo simulation, with independent verification by FO reliability analysis, one obtains resistance factors and reliability indices similar to those found for the limit state of global buckling for other light construction materials, as summarized in Table C2.3-1.

Table C2.3-1. Resistance factors, ϕ , required to achieve target reliability, β , for general buckling of pultruded I-shaped section

| Mean (M) | COV (M) | ϕ ($\beta = 3$) | ϕ ($\beta = 3.5$) | β ($\phi = 0.70$) |
|----------|---------|------------------------|--------------------------|---------------------------|
| 1.10 | 0.05 | 0.75 | 0.69 | 3.22 |
| 1.22 | 0.10 | 0.77 | 0.70 | 3.26 |
| 1.37 | 0.15 | 0.74 | 0.66 | 3.19 |

The ϕ -factors in Table C2.3-1 depend on the specification of $F_{cr,n}$ which, in turn depends on manufacturing quality control, as reflected in the parameters of the Weibull distribution for strength. The *product* of ϕ and R_n determines the reliability associated with design strength in Eq 2.3-1. In probability-based limit states design, nominal strengths customarily are selected between the 1st and 10th percentiles of the strength distribution. In this *Standard*, the 5th percentile of the Weibull distribution was selected as the basis for $F_{cr,n}$ for two reasons. First, the corresponding ϕ -factors are of the magnitude that structural engineers expect for the limit states of interest. Second, the corresponding ϕ -factors for a given target reliability are insensitive to manufacturing quality control, reflected in the statistics of M in Eq. C2.3-7. This can be seen

from the results in Table C2.3-1, where ϕ for a given value of β (e.g., 3 or 3.5) is nearly constant as the COV in M increases from 0.05 to 0.15. This insensitivity is advantageous in codifying the design strength because it means that ϕ depends only on the nature of the limit state while product variability and quality control can be addressed in the specification of the nominal strength or stiffness in accordance with ASTM D7290.

There is a general consensus in the structural engineering profession that target reliabilities should reflect the modes and consequences of occurrence of the design limit states. Reliability targets for limit states that are ductile and relatively benign (e.g., gross deformation; failure of secondary framing members) are lower than reliabilities for limit states that may occur suddenly or have severe consequences (e.g., rupture on the net section; column buckling or overall loss of equilibrium). [Such reliability considerations are recognized explicitly in the Commentary to Section C1.3 of *ASCE Standard 7-10*.] Taking these factors into consideration, along with the reliabilities associated with construction materials likely to compete with pultruded FRP structures in the marketplace, the resistance criteria in this *Standard* are based on the reliability objectives in Table C2.3-2 below. Note that the reliability targets are set as a range, rather than a single value. This is done to limit the number of resistance factors in the *Standard* to a manageable level. A reliability-based examination of LRFD criteria for other common construction materials reveals a similar range associated with criteria for stability, connection failure, etc. The target reliabilities for the member limit states are slightly higher than those for the existing LRFD specifications for cold-formed steel [AISI/CSA/CANACERO 2007] and stainless steel [ASCE, 2008] because pultruded FRP structures exhibit little ductility. The target reliabilities for the connection limit states, on the other hand, are comparable to those in other standards. Table C2.3-3 summarizes the ϕ -factors and reliability indices achieved for the most important limit states in this *Standard*. The resistance factors are contained in each Section of the *Standard*, where appropriate.

Table C2.3-2. Reliability index goals for LRFD of pultruded FRP structures

| Limit state | Target reliability range |
|---|---------------------------------|
| Global instability | 3.0 – 3.5 |
| Local instability | 3.5 – 4.0 |
| Material strength – tension, compression, shear | 3.5 – 4.0 |
| Connection failure modes; bearing, net tension | 4.0 – 4.5 |

Table C2.3-3. Summary of resistance factors to be applied to nominal resistance, defined as the 5-percent exclusion limit, in key limit states

| (1) | (2) | (3) | (4) | (5) | (6) | (7) |
|----------------------------------|------------|----------------|---------|--------|--------|------------------|
| Limit state | equation | Target β | Mean(B) | COV(B) | ϕ | β achieved |
| Tension-ultimate | 3.3-2 | 4.0 - 4.5 | 1.10 | 0.10 | 0.65 | 3.75 |
| Comp-I-Global buckling | 4.4-2 | 3.0 - 3.5 | 0.98 | 0.11 | 0.70 | 3.25 |
| Comp-I Local buckling | 4.4-3 | 3.5 - 4.0 | 1.67 | 0.16 | 0.80 | 3.85 |
| Comp-L Torsional buckling | 4.4-10 | 3.0 - 3.5 | 1.17 | 0.13 | 0.70 | 3.60 |
| Comp-Box-Global buckling | 4.4-11 | 3.0 - 3.5 | 0.83 | 0.04 | 0.70 | 2.90 |
| Flexure – LTB | 5.2.4-2 | 3.0 – 3.5 | 1.27 | 0.21 | 0.70 | 3.0 |
| Flexure – FLB | 5.2.3-2 | 3.5 – 4.0 | 1.23 | 0.15 | 0.80 | 3.25 |
| Web crippling | 5.4.3-1 | 3.5 – 4.0 | 1.27 | 0.16 | 0.70 | 3.5 |
| Axial force/bending ² | 6.2-1 | 3.5 – 4.0 | | | | |
| Torsion | 6.3-2a | 3.5 – 4.0 | 1.05 | 0.18 | 0.70 | 3.6 |
| Plates – tension | 7.5, 7.8.2 | 3.5 – 4.0 | 1.00 | 0.05 | 0.65 | 3.6 |
| Plates – comp., buckling | 7.6, 7.8.3 | 3.5 – 4.0 | 1.05 | 0.05 | 0.70 | 3.6 |
| Plates – bending | 7.3, 7.8.4 | 3.0 – 3.5 | 1.10 | 0.10 | 0.80 | 3.2 |
| Plates – shear | 7.4, 7.7 | 3.0 – 3.5 | 1.10 | 0.10 | 0.80 | 3.2 |
| Pin-bearing failure | 8.3.2-4 | 4.0 – 4.5 | 1.64 | 0.05 | 0.80 | 4.5 |
| Net-section tension | 8.3.2-6a | 4.0 – 4.5 | 1.09 | 0.17 | 0.45 | 4.0 |
| Net-section tension | 8.3.2-6b | 4.0 – 4.5 | 1.19 | 0.15 | 0.45 | 4.5 |
| Net-section tension | 8.3.3-1a | 4.0 – 4.5 | 1.26 | 0.17 | 0.50 | 4.1 |
| Net-section tension | 8.3.3-1b | 4.0 – 4.5 | 1.42 | 0.16 | 0.50 | 4.4 |

Development of time effect factors (λ)

(a) Damage accumulation due to creep-rupture

Failure of pultruded FRP structural elements under sustained load is governed by a creep-rupture phenomenon. The time to failure of an element depends on the sustained stress level, temperature and the presence of moisture, increases in each factor giving rise to shortened times to failure. Furthermore, since glass does not creep, the visco-elastic behavior of the structural element over time depends on the glass content of the material.

A review of experimental data provided by the composites industry describing stress vs time to failure for pultruded materials with various fiber contents loaded in tension revealed that this relation can be modeled as log-log linear, i.e., in approximation,

$$F_v/F_{ut} = 0.67 T_r^{-0.026} \quad (C2.3-8)$$

² Data to define the statistical properties of B over a range of P/P_u and M/M_u could not be located. The reliabilities near the end points of pure flexure or pure compression are approximately the same as for columns (Chapter 4) and beams (Chapter 5).

in which T_f = time to failure under constant stress ratio (hr), F_t/F_{ut} , defined as the ratio of sustained applied stress to (short-term) ultimate tensile strength, and the numbers 0.67 and -0.026 are regression constants. If $T_f = 50$ yr (438,300 hr), Eq. C2.3-8 yields $F_t/F_{ut} = 0.478$; in other words, the rod could sustain, on average, a stress of approximately 48% of its short-term tension strength for 50 yr without failure. However, the maximum failure time observed in these experiments was approximately 3½ years, requiring extrapolation far beyond the realm of experimental data to estimate the 50-yr sustained strength. Moreover, the glass content by weight of 73% is substantially in excess of what is typical in pultruded FRP structural shapes. Others have found that when specimens with typical glass fiber content are loaded in tension to 30% of their ultimate tensile strength at a temperature of 25°C (77°F), failure may occur in as low as 15 years. Finally, experience with fiberglass plastic pipes subjected to sustained pressure indicates that the strength at 11.5 years is 35% to 40% of its ultimate tensile strength.

Accepting the log-log linear relationship between sustained stress and time to failure implied by Eq. C2.3-8, and assuming that (a) the ultimate tensile strength can be sustained for a period of 6 minutes (0.1 hr) without failure by creep-rupture, and (b) the sustained stress causing failure in 50 years is $0.33F_{ut}$, the relationship between stress ratio, SR, and time to failure (in hours) becomes,

$$SR = F_t/F_{ut} = 0.847T_f^{-0.072} \quad (C2.3-9)$$

With the exception of permanent loads (dead load or fluid pressure in Eq 1.5-1), the design loads used to determine the required strength do not persist over the 50-yr service life of the structure. Structural loads are stochastic processes that vary in time, and their temporal effects differ from combination to combination, making the time effect factors dependent on the load combination. The appropriate time effect factor must be determined through a damage accumulation analysis that is similar to the Palmgren-Miner approach to modeling variable amplitude fatigue. In a simple model, the time-varying load is modeled as a sequence of pulses, each with random intensity, S_i . Prior to service, the accumulated damage, D , equals zero. The damage increment during each load pulse interval is calculated as $D_i = 1/T_f(F_i)$, in which F_i = stress from load S_i and $T_f(F_i)$ = time to failure under sustained stress, F_i , determined from Eq. C2.3-9. The damage accumulation hypothesis states that failure occurs when the summation,

$$D = \sum D_i \geq 1 \quad (C2.3-10)$$

in which the summation is performed over the random number of load pulses to occur in 50 years. The (time-dependent) stress, F_i , is fixed by the LRFD criteria used for strength or serviceability, whichever controls the design.

(b) Time effect factors for load combinations in Section 1.5

The design strength criterion for permanent load (Eqs. 1.5-1 and 2.3-1) is,

$$\phi F_{cr,n} A_{g,n} \geq 1.4 D_n \quad (C2.3-11)$$

The service stress needed for damage accumulation analysis (assuming, for simplicity, that $A_g = A_{g,n}$) is $F_i = D/A_g$. Substituting A_g determined from Eq C2.3-11 into this expression yields the service stress,

$$F_i = \phi F_{cr,n} (D/D_n) / 1.4 \quad (C2.3-12)$$

for a code-compliant member. If the strength is described by a two-parameter Weibull distribution with, e.g., a COV of 0.10, then $F_{cr,n}$ is related to the mean value by $F_{cr,n} = \mu_{Fut}/1.22$. Substituting this expression into Eq. C2.3-12 and assuming that $\phi = 0.65$ (Table C2.3-3 - tension), we find that the average value of $F_i \approx 0.4\mu_{Fut}$. In other words, if the governing LRFD strength criterion is satisfied, the average stress in the pultruded FRP element under permanent load, defined by Eq 1.5-1, is on the order of 40% of its tensile strength.

At the other end of the time scale for structural loads, the durations of structural actions due to impact or peak wind or earthquake effects are sufficiently small (on the order of seconds to hours) that no correction for time effect is necessary in load combinations Eqs. 1.5-4 through 1.5-7.

Load combinations Eqs 1.5-2 and 1.5-3 involve time-varying gravity loads due to occupancy live load, roof live load, snow and rain load, and the time effect factors for those load combinations fall between the limits 0.4 to 1.0 in the previous paragraph. Time effect factors for these combinations are developed in a two-stage process. First, a structural element is designed for a target β , and the required ϕ is determined without considering creep-rupture, as described previously. Second, the limit state probability (or reliability index) for the limit state of creep-rupture in the same structural element is determined, and a second resistance factor required to achieve the same β , denoted ϕ^* , is determined. By definition (cf Eq. 2.3-1), $\lambda = \phi^*/\phi$. This factor depends only on the principal action that governs the load combination (Turkstra and Madsen, 1980); thus, the dependence on load combination.

Statistical analysis of live loads in light occupancies, such as general and clerical offices and residential buildings, has shown that the sustained live load averages about 0.20 to 0.25 times the nominal live load, L_n , stipulated in Table 4-1 of ASCE Standard 7. Thus, the service stress for a code-compliant structural member averages less than $0.16\mu_{Fut}$. Modern stochastic load process models of live loads have revealed that the full value of L_n , is approached rarely during a 50-yr service period, and then only for short periods of time due to transient effects; indeed, the value $L_n = 50$ psf for general and clerical offices is close to the mean value of the *maximum* live load to occur in a 50-yr service period, but the *duration* of that maximum load³ is on the order of 6 hr or less. Because of the highly nonlinear nature of Eq. C2.3-9, creep-rupture damage due to light-occupancy live load will only occur during a few near-maximum load events during the 50-yr service period. The results of the damage accumulation analysis for light-occupancy live loads yielded $\lambda = 0.90$. In contrast to light-occupancy live loads, only limited live load survey data exist for storage and industrial buildings (Chalk and Corotis, 1980). In such occupancies, the transient component of the live load is negligible and the temporal variations in load arise mainly from fluctuations in the sustained component of the live load. Making plausible assumptions concerning the temporal variation of such loads, $\lambda = 0.60$. Miscellaneous roof live loads, L_r , are due primarily to maintenance, and are intermittent in nature. Survey data on such loads are unavailable. Making plausible assumptions regarding frequency of roof maintenance and relating the maximum roof load to the nominal load in *ASCE Standard 7*, $\lambda = 0.75$.

Snow loads often govern roof design in the northern tier of states. The annual extreme roof snow load averages 0.20 to 0.25 times the nominal snow load in ASCE Standard 7; the maximum snow load in a 50-yr service period is about 85% - 90% of the nominal snow load, depending on area,

³ The 50-yr maximum total live load in most light occupancies, which correlates to L_n , usually arises from emergency crowding, a phenomenon that is not captured by live load surveys.

and its duration is approximately 1 week. Thus, the time effect factor for load combination 1.5-3 ($\lambda = 0.75$) is less than that for light-occupancy live load.

C2.3.2 Prequalified FRP Building Products

When compliance with the intent of this Standard with regard to safety or serviceability cannot be established by analysis, proof of compliance may be determined by load tests. Such an approach is permitted by both *ASCE Standard 8-02, Specification for the design of cold-formed stainless steel structural members* and *AISI S100-07, CSA S136-07, North American specification for the design of cold-formed steel structural members*. The determination of strength and stiffness of structural components and systems by testing is based on achieving the same level of reliability and performance as achieved by analysis for gravity load design. It is assumed that the reference strength is the mean value of strength determined directly from structural testing. The resistance factor depends on the variability in the test data, measured by the coefficient of variation, and the influence of the number of specimens tested. The nominal strength and resistance factor in Section 2.3.2 depend solely on the load test results. The stipulated values of p for evaluating the t-statistic achieve a reliability index, β , approximately equal to 3.5 for structural members and 4.5 for structural connections and connecting elements. As an example, if a structural component is tested, with $n = 10$ and test COV is 0.15, Eq (2.3-3) yields $\phi_p = 0.63$ for a member and $\phi_p = 0.51$ for a structural connection. (The corresponding values using AISI Standard S100-07 would be 0.62 and 0.47, respectively.) The design strength becomes less conservative as the sample size increases, providing motivation for using larger samples to determine compliance of the structural product. A minimum of 10 samples is required for consistency with the requirements in Section 2.4.3.

C2.4 Nominal Strength and Stiffness

C2.4.1 Nominal Strength

The strength of FRP pultruded structural members, components and systems is dependent on service conditions and environmental exposure. The nominal strength, R_n , in this *Standard* is calculated as the product of a reference strength, R_o , and a series of adjustment factors, C_i , that account for differences between the standard conditions under which engineering properties of structural elements are determined and *in situ* conditions of structural service. This general approach has been used successfully in *ASCE Standard 16-95, LRFD for engineered wood structures*.

While this *Standard* provides nominal strength and stiffness values for most typical exposure conditions, it does not address the design for unique exposures such as contact with specific chemicals, radioactive materials, steam, etc. For these unique applications, the designer should consult the available literature or conduct experiments to aid in developing modifiers for design resistance values.

C2.4.2 Reference Strength and Stiffness

The reference strength and stiffness are determined in accordance with appropriate ASTM standards stipulated in Section 1.3 under standard conditions that are easily controlled and replicated in a laboratory or manufacturing environment. It is expected that the reference conditions will be adequate for a substantial proportion of typical designs of protected building structures, thus avoiding the need for additional adjustments.

The *Standard* is limited in application to the design of new structures, and the design strength and stiffness values provided in this *Standard* are for new structural products placed in service for the first time.

C2.4.3 Statistical Basis for Reference Strength and Stiffness

In this *Standard*, the uncertainties in strength and stiffness are modeled probabilistically, to the extent possible. Such models permit the values of reference strength and stiffness to be determined on a comparable basis for competing building products and test data samples of different size. The *Standard* requires that the design strength for limit states involving stability considerations be determined using the *adjusted 5th percentile values* of elastic and shear moduli. For typical coefficients of variation in modulus, the 5th percentile is approximately 84% to 92% of the mean value. Note that the required strength determined by analysis utilizes the *adjusted mean* moduli.

The technical basis for determining reference strength and stiffness values is explained by Zureick, Bennett and Ellingwood (2006), which is reflected in ASTM Standard D7290. An examination of several datasets revealed that the two-parameter Weibull distribution provided the best overall model for tension strength and modulus of elasticity. The two-parameter Weibull distribution is defined by,

$$F_X(x) = 1 - \exp [-(x/u)^\alpha]; \quad u, \alpha > 0 \quad (C2.4-1)$$

in which X is the random variable being analyzed, and u, α are parameters of the distribution, which are related to the mean, μ_X , and coefficient of variation, V_X , of X by,

$$\mu_X = u \Gamma(1 + 1/\alpha) \quad (C2.4-2a)$$

$$V_X = [\Gamma(1 + 2/\alpha) / \Gamma^2(1 + 1/\alpha) - 1]^{1/2} \quad (C2.4-2b)$$

in which $\Gamma(x)$ = complete Gamma function, evaluated at x . The 5-percentile value of X is determined by setting $F_X(x) = 0.05$ and solving for $x = x_{0.05}$:

$$x_{0.05} = u (0.05129)^{1/\alpha} \quad (C2.4-3)$$

This *Standard* uses either the mean value or 5-percentile value of reference strength and stiffness, depending on the application of interest.

The quality of the estimates of the mean value and coefficient of variation from samples of test data depends on the size of the test sample, which is reflected by stipulating the reference strength at the 80% lower confidence interval on the 5-percentile of the distribution. For given sample statistics, the reference value for a building product based on a sample of 20 tests will be less conservative than the reference value for that same product based on a sample of only 10 tests, which provides an incentive for the producer to invest in additional tests to determine the reference value. A minimum of ten (10) tests is required to determine any reference strength or stiffness value in this *Standard*.

C2.4.4 Adjustments to Reference Strength

The reference strength and stiffness values of pultruded FRP structures must be adjusted for structural design, as specified in Section 2.4.4, for specific service or end-use conditions that differ from the standard conditions in Section 2.4.2 used to determine the reference strength and stiffness.

(a) Adjustment factors for end use.

Moisture and humidity: Reference conditions in Section 2.4.2 cover the range commonly encountered with protected structures (dry use conditions). An adjustment factor, C_M , should be applied to calculate adjusted member resistances under moisture conditions of service outside of the reference end-use conditions.

Temperature: The strength and stiffness of pultruded FRP shapes is temperature-dependent, and excessive deformations due to creep at elevated temperature and deterioration in strength may occur at sustained temperatures in excess of 90°F (32°C) (Engindeniz and Zureick, 2008). At temperatures below 90°F (32°C), the immediate effect on strength or stiffness is reversible, and the structural component will fully recover its strength and stiffness when the temperature is reduced to normal. Adjustment factor, C_T , is applied to calculate adjusted member resistance to account for effects of service temperatures falling in the range between 90°F (32°C) and 140 °F (60°C), which is consistent with the minimum value $T_g - 40°F$ (22°C) stipulated in Section 1.1.2. Factor C_T has been calculated so that the product $C_M C_T$ represents approximately the combined effect of moisture and temperature. Supporting data for these adjustments are limited; accordingly, adjustment factors for sustained service temperatures about 140°F (60°C) or for other service environments may require supplementary testing.

Chemical environment: Effects of aggressive chemical environments (high alkalinity, acidity) vary depending upon the characteristics of the exposure and the material system of the structural members and components. The product manufacturer may recommend that the Engineer use an adjustment factor C_{CH} when designing a structure that may be exposed to an aggressive environment.

Fire-retardant treatment: This *Standard* does not provide specific recommendations for adjustment factors for pultruded FRP products treated with fire-retardant materials or protective coatings and systems. While the adjustment factor would be 1.0 for most commercially available treatments, the designer is responsible for obtaining appropriate adjustment factors to apply to nominal resistance of products obtained from suppliers of such materials or products.

(b) Adjustment factors for member strength in structural assemblies

Adjustment factors may be applied to modify the reference flexural strength and stiffness of members in structural assemblies to account for increased strength and stiffness as a result of load-sharing and composite action between repetitively used elements in uniformly loaded framing systems.

C2.4.5 Notches, Holes and Other Stress Concentrations

Notches, copes and holes in webs or flanges and other stress concentrations in pultruded FRP structural members can affect their strength and stability. The designer is cautioned that such

stress concentrations can lead to premature local failure in the section and should be avoided wherever possible. When stress concentrations cannot be avoided, their locations should be reinforced by doubler plates or other means.

C2.5 Stability of Frames and Members

C2.5.1 General Requirements

The analysis of stability of a structural system requires that the behavior of the structure as a whole be considered, as well as the behavior of individual components within the structure. Pultruded FRP composite structures are light and flexible relative to most conventional civil engineering structures. Secondary (P-delta) effects can easily develop in such structures from their deflected shapes and may become significant in frames with slender compression members that are subjected to combinations of gravity and lateral loads. In braced frames, increases in axial force may occur in the bracing members. In unbraced frames, additional axial forces and moments may be developed in both columns and beams, and special consideration should be given to the analysis of the stability of such frames.

C2.5.2 Design Requirements for Frame Stability

The Structural Stability Research Council (SSRC, 1998) has recommended the “notional load” approach, in which a notional horizontal load is applied at each story in the frame in addition to any other lateral loads. This accounts for initial out-of-plumbness of the frame. The required strength of the frame then is determined directly through a second-order structural analysis, and the amplified forces can be correctly distributed within the frame. This method is consistent with computerized structural analysis and design, and is appropriate for flexible light-frame structural systems. In this *Standard*, the notional load $0.0025\Sigma P_i$, where ΣP_i = gravity load applied to the frame at level i , corresponds to a structural frame that is initially out-of-plumb by 1/400 times its height.

C2.5.3 Required Strength of Frames

The required strength for pultruded FRP composite structural systems must be determined by means of a second-order structural analysis, in which the equilibrium of the frame is determined from its deformed shape. The capability for performing such an analysis is available in many computer programs used in structural design. If a direct second-order structural analysis is used in design, that analysis must be performed using factored loads, as the principle of superposition of forces and deformations does not apply.

Equations 2.5-1 through 2.5-5 permit the determination of required strength through an elastic first-order structural analysis in which the second-order effects in the plane of bending are taken into account through multipliers B_1 and B_2 on the non-sway and sway axial forces and moments in the plane of bending. This approach is similar to the approach to frame stability that has been used successfully in the *AISC Specification for Structural Steel Buildings* (AISC, 2010) and its basis is described in the SSRC Guide (1998) and by Galambos and Surovek (2008). In the general case, the first-order moments produced by gravity forces, M_{nt} , are multiplied by B_1 , while the first-order moments produced by forces causing sway of the frame, M_{lt} , are multiplied by B_2 . The axial forces, $P_u = P_{nt} + P_{lt}$ in Eq 2.5-3, are not amplified, an approximation which is acceptable for pultruded FRP frames. This approach results in a conservative required strength over the practical range of frame deflections in building structures.

Factor B_1 reflects the amplification of first-order moment by the effect of axial force multiplied by the deflection of the member in the plane of bending with respect to the chord connecting its end points, and represents an individual member effect. This moment amplification depends on the magnitude of axial force, reflected by the ratio P_u/P_e , and the moment gradient along the length of the member from the loads causing flexure, reflected by $C_m \leq 1.0$. Equation 2.5-5 applies if the member flexure is caused only by end moments. When member flexure is caused by concentrated or distributed loads within its length, it is conservative, but not unduly so, to use $C_m = 1.0$.

Factor B_2 causes the moments and shears in the plane of bending within a story to be amplified for the effects of gravity forces acting through the sway of that story. Thus, in contrast to factor B_1 , which represents a *member* effect, B_2 represents the effect of *story* deformation on stability. If the inter-story drift is limited by design to a fraction of story height (e.g., a common serviceability check in inter-story drift would limit its value to story height/400; thus, $\Delta_1/L < 0.0025$), then B_2 determined from Eq. 2.5-4 can be estimated in advance of designing the structural system. The *AISC Specification* permits an alternative expression for B_2 :

$$B_2 = 1 / [1 - (\Sigma P_u / \Sigma P_e)] \quad (C2.5-1)$$

in which ΣP_u = sum of required axial strength of all columns in the story considered and ΣP_e = sum of Euler buckling strengths of all columns within that story. This alternative to Eq 2.5-4 is not presented in Section 2.5.3 because Eq 2.5-4 is (a) more straightforward to use in the amplified first-order structural analysis represented by Eqs 2.5-1 and 2.5-2, and (b) contains the first-order lateral deflection as an explicit parameter, and (c) does not require the calculation of effective length, KL. It should be noted that the term $B_2 M_{1i}$ affects not only the column forces but also the forces in members that frame into the column.

The *AISC Specification* (2010) limits the use of this method to cases where the ratio of second-order to first-order story drift is less than 1.5. Since serviceability requirements would be difficult to meet at such drifts in pultruded FRP frames, this limitation is not imposed herein.

C2.5.5 Bracing and Lateral Support

The bracing requirements are intended to allow a braced member to develop its full design strength based on the unbraced length between the bracing points. The requirement for both minimum strength and stiffness for bracing elements to be effective is based on work by Winter (1960). The provisions for bracing strength and stiffness in this *Standard* have been adopted from the *AISC Specification*. However, the resistance factor, ϕ , has been taken out of the expressions for stiffness for simplicity and the numerical coefficients have been rounded. Furthermore, all required strengths and stiffnesses for bracing are in units of (lb, in, radians). The *AISC Specification* distinguishes between *relative bracing*, which controls the relative movement between two braced points and *nodal bracing*, which resists movement only at the point of attachment. Because of the relative flexibility of pultruded FRP composite members, the bracing requirements in this *Standard* are based, for conservatism, on the formulas for nodal bracing.

C2.5.5(a) Beams. When flexure of a beam occurs about its weak axis, lateral support of the beam is not required. Conversely, when flexure of a beam occurs about its strong axis, the beam must be braced sufficiently to prevent twist of the cross section. Beam twisting can be controlled by lateral bracing and/or by torsional bracing. Note that lateral bracing that is attached near the

centroid of a beam is ineffective in preventing lateral-torsional buckling (LTB). Support to prevent rotation and/or lateral displacement shall also be provided at points of concentrated load.

Note that points of inflection cannot be considered as effective brace points because cross-section twist still can occur at an inflection point. At a point of inflection, bracing must be attached to both flanges to prevent torsion.

C2.5.5(b) Columns. The required axial strength is used to calculate the brace strength and stiffness.

C2.5.5(c) Frames. Requirements for frame stability at any story should be combined with the lateral force and drift requirements from wind or seismic effects.

C2.6 Design for Serviceability

Serviceability limit states involve the disruption of the function of the building or other structure, its appearance, maintainability, durability and comfort of its occupants under conditions of ordinary use (service conditions). Serviceability criteria to guard against such limit states are an essential design consideration with any light-frame construction technology, where limits on elastic deflection or vibration, rather than strength, frequently control member proportions and neglect of serviceability may lead to an excessively flexible structural system (Ad Hoc Committee on Serviceability Research, 1986). Such criteria may be particularly important in pultruded FRP systems in which the ratio of material strength to modulus of elasticity is high. Serviceability limits depend on the function of the building or other structure and the perceptions of its occupants or users. Accordingly, it is not possible to specify serviceability limits that are equally applicable to all structural systems. Such limits require an assessment of the facility by the Engineer, architect and owner of all functional and economic requirements and constraints. It should be noted that building occupants can perceive structural deflections and motions that are far less than those associated with incipient damage or failure. Such perceptions may be interpreted incorrectly as signifying that the structure is unsafe and diminish its commercial value. The economic consequences of serviceability problems can be substantial. The effectiveness of serviceability criteria in meeting the performance expectations for the facility is strongly related to the investment to achieve facility performance above and beyond the requirements for public safety.

The following general guidelines are intended to provide a starting point for the Engineer to assess serviceability limit states. Additional guidelines are provided in Appendix C of *ASCE Standard 7-10* and its commentary.

C2.6.1 Deformations

Excessive vertical deflections of floors or roofs or lateral deformations (drifts) of the building frame may be visually objectionable or may cause separation, cracking or leakage in exterior cladding and damage to windows, doors, and interior non-structural partitions and finishes. Deformations on the order of 1/300 times span or story height are easily visible and may lead to minor architectural damage, while deformations on the order of 1/200 times the span or story height may impair the operation of moveable non-structural components (windows, sliding doors or partitions) that are constructed to be integral with the structural system (Ad Hoc Committee on Serviceability Research, 1986). Such serviceability limit states can be addressed by limiting the structural deflection or lateral drift under service loads (e.g., Eqs 1.5-8 and 1.5-9) to a stipulated

value that depends on the building performance objective, as agreed upon by the owner, architect and engineer. For example, it is common structural engineering practice to limit static lateral drifts to on the order of 1/400 times the building or story height (ASCE Task Committee on Drift Control, 1988); this limit minimizes the likelihood of damage to properly installed cladding and, as a side benefit, minimizes the development of P- Δ effects. Approaches such as these effectively enforce a lower limit on the stiffness of the structural system.

Under sustained loading, pultruded FRP structural members will undergo additional time-dependent deformations due to creep which usually occur at a slow but persistent rate over long periods of time. The creep rates may be greater for members that are exposed to varying temperature and/or moisture conditions than for members in an environmentally protected environment. In certain applications, it may be necessary to limit the deflection under long-term loading to levels specified by the client, depending on the service period and structural performance requirements. This deflection limit state should be checked using serviceability load combination 1.5-10, in which the live load term, $0.5L$, represents the average live load over an extended service period. The term $K_{cr}(t)$ appearing in Eqs 2.6-1 and 2.6-2 is the time-dependent creep factor, which is based on Findley's model (1944) with constants determined from a synthesis of applicable experimental creep data (Zureick, 1997).

C2.6.2 Vibrations

Structural vibrations of floors or of the structural system as a whole may cause occupant discomfort and impair the operation of building service equipment. Such vibrations depend not only on stiffness but also mass distribution and structural damping. Attempts to control such vibrations through such measures as limiting the static deflection of the floor under live load to $\text{span}/360$ are likely to be ineffective and uneconomical. While the Engineer must consider the dynamic nature of excitation and response in dealing with this limit state, simple dynamic models often are sufficient to identify possible problems and suggest remedial measures (Ellingwood, 1989; Allen, 1990).

Excessive floor vibrations can be mitigated by measures that limit floor accelerations to levels that are not disturbing to the occupants and do not damage service equipment. The level of occasional vibratory motions that are perceived or tolerated by the building occupants depends on whether the motion is transient or steady-state, their performance expectations, and their level of activity (Ellingwood, 1989). Continuous vibrations (over a period of minutes) with accelerations on the order of $0.005g$ (0.05 m/s^2) are annoying, while those engaged in physical activities may tolerate steady-state accelerations on the order of $0.05g$ (0.5 m/s^2). Thresholds for transient vibrations (lasting only a few seconds) are higher, and depend on the level of damping present. For a finished floor with 5% (or more) damping, peak transient accelerations of $0.1g$ (1 m/s^2) may be tolerated occasionally.

Many common occupant activities impart dynamic forces to a floor system at frequencies (or harmonics) in the range of 2 to 6 Hz (Allen, 1990). Objectionable floor vibrations often can be mitigated effectively by tuning the frequency of the floor system away from these dominant frequencies (Allen and Murray, 1993). For typical floor spans in light-frame construction, the likelihood of objectionable vibration is minimized if the fundamental frequency of the floor is greater than about 8 Hz. If tuning is not practical, other approaches are possible (e.g., Murray, et al, 1997; Fisher, et al, 2003). For example, in an earlier study of floor vibration in residential construction (Onysko, 1988), it was found that static deflection under a concentrated load at midspan provided the best measure for identifying floors with excessive springiness under

occupant movement. Based on this and other studies, the following criterion was adopted in Commentary C10 of *ASCE Standard 16-95*, based on the assumption that the floor system is simply supported:

Under a concentrated load of 225 lb (1 kN) applied at mid-span of the floor, the static deflection, δ , of the floor should not exceed:

$$\delta \leq 1.2 / \ell^{1.2} \text{ inches} \leq 0.08 \text{ inch} \quad (\text{US}) \quad (\text{C2.6-1})$$

$$\delta \leq 7.5 / \ell^{1.2} < 2 \text{ mm} \quad (\text{SI}) \quad (\text{C2.6-2})$$

in which ℓ = span.

Wind-induced vibrations seldom are a serviceability problem for low-rise buildings.

C2.7 Design for Ponding

Flat roofs with insufficient drainage may retain water due to the deflection of the roof framing. If the roof framing is insufficiently stiff, the increased load due to the accumulation of water may lead to collapse of the roof. An exact evaluation of ponding requires a second-order structural analysis of the roof system. The provision in Section 2.7 is similar to that followed by the *AISC Specification* (2010), with modification for material properties, and establishes sufficient conditions for stability of the roof system without the need for a second-order analysis.

C2.8 Design for Fatigue

Fatigue is not expected to be a common design consideration in members and connections in buildings and similar structures designed using pultruded FRP composites. In such structural systems, changes in load intensity or significant load cycles occur relatively infrequently. Furthermore, the stresses developed at the serviceability limit states, which often will control design, are far below the stresses at which fatigue damage might be expected to occur. During the occurrence of design winds or earthquakes, the number of significant load cycles (load reversals) typically would be on the order of 100 to 500 cycles, which is not sufficient to cause significant fatigue damage.

The non-homogeneous and anisotropic nature of composite materials makes the fatigue damage process depend on the properties of the reinforcement and the matrix (Scholte, 1993). Because of the complexity of this process, in situations where fatigue damage must be considered in design, the usual approach for design is through the Basquin, or “S-N” equation:

$$N_f (\Delta S)^m = C \quad (\text{C2.8-1})$$

where N_f = cycles to fatigue failure (arbitrarily defined), ΔS = stress range due to service (unfactored) live loads, and (m, C) = constants determined from a regression analysis of constant amplitude fatigue tests. There appears to be mild dependence of fatigue life on the mean cyclic stress, making Eq C2.8-1 an appropriate simplification. Fatigue is most likely to be problematic for structural connections. The relations presented in Table 2.8-1 for four general categories of fatigue-sensitive details are believed to be conservative for civil structures. In Eq C2.8-1, the constant m is assumed to equal 8.5 for all four categories. The constant C depends on the stress

raiser at the fatigue-critical detail; in civil structures, fatigue-critical details are likely to be identified with bolted connections. The limited fatigue data that exist for composites appear to have been developed for aerospace or marine rather than civil applications (Committee, 1991).

The stress range is expressed as a ratio of cyclic stress to tensile failure stress. For example, if the cyclic stress ratio is 0.22 (a typical value), then the total number of stress cycles must be limited to 3,900,000, 233,000, 31,000 and 3,900, respectively, for Categories I, II, III and IV details. Conversely, if the performance requirement is for the structure to sustain at least 500,000 cycles, then the maximum stress range due to repetitive applications of live load for a Category II detail must be limited to 20% of F_{ut} .

C2.9 Design of Connections

Section 2.9 provides minimum requirements applicable to structural connections. Specific design requirements for connections are provided in Chapter 8.

Connections play an essential role in the performance of pultruded FRP structures. While connectors and connecting elements (e.g., gusset or splice plates; angles) have been fabricated using FRP materials, the transfer of structural actions through a connection is complex and the anisotropic nature of FRP connecting elements used in connection design makes them difficult to proportion correctly in the routine design of connections in trusses and frames. For this reason, the *Standard* requires that connections be designed using metallic fasteners and connecting elements. FRP connecting elements and fasteners are permitted where the connection is prequalified. Chapter 8 provides provisions for the sizing of FRP elements. This requirement will simplify connection design for the majority of pultruded FRP structures and will have little impact on cost, since the cost of connections is dominated by labor in fabrication rather than by materials.

C2.10 Gross and Net Areas

C2.10.3 Effective Net Area

The effective net area accounts for the effect of shear lag in connecting members in which tension force is transmitted by bolts or adhesives through some, but not all, of the elements of the cross sections. The effective net area is calculated by $A_e = U A_n$, in which A_n = net area and U = shear lag factor. The factor U depends on the nature of the mechanism of tension force transfer. The approach for dealing with shear lag is similar to the approach for connections in the *AISC Specification*, adjusted to take into account the features of connections and connecting elements in pultruded FRP composite structures. The *AISC Specification* presents an equation for U based on connection eccentricity and connection length. While there is sufficient data for steel connections to validate this equation, such data does not yet exist for FRP pultruded composites. Accordingly, the *Standard* takes a simplified and conservative approach to the specification of U .

References - Commentary Chapter 2

Ad Hoc Committee on Serviceability Research (1986). Structural serviceability: a critical appraisal and research needs. *J. Struct. Div. ASCE* 112(12):2646-2664.

AF&PA/ASCE (1996). *LRFD for Engineered Wood Construction (AF&PA/ASCE Standard 16-95)*. American Society of Civil Engineers, Reston, VA.

AISC (2010). *Specification for Structural Steel Buildings*. American Institute of Steel Construction, Inc., Chicago, IL.

AISI/CSA/CANACERO (2007), *North American specification for the design of cold-formed steel structural members (AISI S100-07, CSA S136-07)*, American Iron and Steel Institute, Washington, DC.

Allen, D.E. (1990). Building vibrations from human activities. *Concrete International* 12(6):66-73.

Allen, D.E. and Murray, T.M. (1993). Design criterion for vibrations due to walking. *Engineering J. AISC* 30(4):117-129.

ANSI/AF&PA NDS-2005 National Design Specification for Wood Construction. American Forest and Paper Association Washington, DC.

ASCE Task Committee on Drift Control (1988). Wind drift design of steel-framed buildings: state of the art." *J. Struct. Div. ASCE* 114(9):2085-2108.

ASCE (2008), *Specification for the design of cold-formed stainless steel structural members (SEI/ASCE Standard 8-02)*, American Society of Civil Engineers, Reston, VA.

ASTM (2006). *Standard D7290-06 Standard practice for evaluating material property characteristic values for polymeric composites for civil engineering applications*. American Society for Testing and Materials, Philadelphia, PA.

Chalk, P. and Corotis, R.B. (1980). A probability model for design live loads. *J. Struct. Div. ASCE* 106(10):2017-2030.

Committee on life prediction methodologies for composite materials (1991). *Life prediction methodologies for composite materials*. National Materials Advisory Board, NRC National Academy Press, Washington, DC.

Ellingwood, B.R. (1989). Structural serviceability. *Engineering J., AISC.*, 26(1):1-8.

Engindinez, M. and Zureick, A.-H. (2008). Deflection response of glass fiber-reinforced pultruded components in hot weather climates. *J. Composites for Const. ASCE* 12(3):355-363.

Fisher, J.M., West, M.A. and Griffis, L.G. (2003). Serviceability design considerations for steel buildings. Steel Design Guide No. 3, Second Edition, American Institute of Steel Construction, Chicago, IL.

Galambos, T.V. and Surovek, A.E. (2008). *Structural stability of steel: concepts and applications for structural engineers*. John Wiley and Sons, Inc., New York, NY.

Murray, T.M., Allen, D.E. and Ungar, E.E. (1997). *Floor vibrations due to human activities*. Steel Design Guide No. 11, American Institute of Steel Construction, Chicago, IL.

Onysko, D.M. (1988). Performance and acceptability of wood floors – Forintek studies. *Proceedings, Symposium on Serviceability of Buildings*, National Research Council of Canada, Ottawa, pp. 477-494.

Scholte, H.G. (1993). Fatigue characteristics. in *Composite Materials in Maritime Structures, Volume 2* (edited by Sheno and Wellicome), Cambridge University Press, Cambridge, United Kingdom, pp. 178-198.

Structural Stability Research Council (1998), *Guide to stability design criteria for metal structures, 5th edition* (T.V. Galambos, ed.), John Wiley & Sons, New York, NY.

Turkstra, C. and Madsen, H. 1980. Load Combinations in Codified Structural Design. *J. Struct. Div., ASCE* 106(12):2527-2543.

Wang, Y., and Zureick, A.H. (1994). Characterization of the Longitudinal Tensile Behavior of Pultruded I-shape Structural Members Using Coupon Specimens. *Composite Structures*, no. 29, pp. 463-472.

Zureick, A.-H. (1997). Polymer composites for infrastructure. in *Progress in Durability Analysis of Composite Systems, Proc. 3rd Int. Conf.* (Edited by Reifsnider, Dillard and Cardon), A.A. Balkema, Rotterdam, The Netherlands, pp. 181-184.

Zureick, A. and Scott D. (1997). Short-Term Behavior and Design of Fiber-Reinforced Polymeric Slender Members under Axial Compression. *J. Composites for Const., ASCE*, Vol. 1, No. 4, pp. 140-149.

Zureick, A., and Steffen, Robert. (2000). Behavior and Design of Concentrically Loaded Pultruded Angle Struts. *J. Struct. Engrg., ASCE*, Vol. 126, No. 3, pp. 406-416.

Zureick, A.-H., Bennett, R. and Ellingwood, B.R. (2006). Statistical characterization of fiber-reinforced polymer composite material properties for structural design. *J. Struct. Engrg. ASCE* 132(8):1320-1327.

C3. DESIGN OF TENSION MEMBERS

C3.1 Scope

A symmetric laminate with symmetric reinforcement consists of every lamina of certain orientation above the midplane of a laminate must be matched with an identical lamina of the same orientation and same fiber yield at the same distance below the midplane. The scope of this section is limited to structural shapes with reinforcement in the longitudinal and transverse direction. This section does not cover the design of tension members with unidirectional reinforcement; however, the pultruded members with unidirectional reinforcements such as rods have to be prequalified before using them as structural members as per Section 2.3.2. As stated in the scope (Section 3.1), members under longitudinal tension loads parallel to the longitudinal axis that are not passing through the center of gravity or the shear center of the member cross section shall be designed for combined axial and other load effects as per the provisions given in Chapter 6. Design equations provided herein correspond to the rovings and continuous filament mats. No experimental data is available to design structural shapes made of stitched or woven mats. The proposed design equations will be modified as the experimental data for shapes with stitched or woven mats is made available.

C3.3 Design Tensile Strength

If pultruded FRP composite members experience tensile failure, these materials do not yield but instead rupture without warning. Unlike steel members, pultruded FRP members do not have a yield plateau. In tension members, the rupture strength depends on constituent materials properties, fiber architecture, fiber continuity between the web and the flange of a member and reduction in gross sectional area to accommodate bolts and bolt configuration in the connection zone (e.g. tension load is transferred to some but not all cross sectional elements of a member such as webs and flanges).

Web-flange junction failure was observed based on bolted joint tests (Bataineh and GangaRao, 2009). Typically, tensile resistance offered by the flange is different from the web because of variations in axial stiffness of the web from the flange, which could lead to shear induced failure in the continuous filament mat reinforcement and/or junction failure. Therefore, to avoid web-flange junction failure, the percentage of continuous fiber in each pultruded FRP structural element in the direction of the longitudinal axis of the member shall not be less than 30% of the total fiber reinforcement by volume for shapes and not less than 25% of the total fiber reinforcement by volume for plates (Section 1.3.1).

In addition, interlaminar shear failure within a flange or a web was noted before web-flange junction failure. Such shear failure was attributed to either shear lag in the fixture grips or in a joint that is connecting tension members. To avoid the initiation of interlaminar shear failure followed by tension rupture or vice versa, minimum fiber volume fraction of continuous fiber in the direction of the longitudinal axis is recommended as stated in the above paragraph. Based on the above discussions two rupture limit states are identified for a tension member:

- 1) Tensile rupture in the gross section of a member is equal to the product of the tensile strength from a coupon test and the gross area.
- 2) Tensile rupture in the net cross sectional area of a member accounts for the stress concentration induced because of the presence of a circular open-hole. Circular open-holes in a tension member

are provided to run utility lines and these holes are not plugged as in the cases of joints with bolted connections.

The effective stress concentration factor is identical to the inverse of the open-hole tensile strength reduction factor in the longitudinal or pull direction (as in Eq. 7.5.2-2, Chapter 7). The effective stress concentration factor is intended for use at any location along the length of a tension member where there is a stress raiser such as a circular open-hole; but not in the connection area. The effective stress concentration factor for an FRP plate of finite width and circular open hole is found to be 1.43 from experimental data. However, stress concentration factors for holes with rectangular or other shapes or other changes in the cross sectional area due to local stiffening may be evaluated through numerical analysis or other rational methods.

The effective stress concentration factor is empirical and will be used till more accurate stress concentration factors are developed.

The effective stress concentration factor has been developed empirically based on limited tension testing of coupons from pultruded structural shapes with uni-directional rovings and continuous filament mat construction and thickness not exceeding 1/4 in. during which the hole diameter-to-width ratio varied from 0.186 to 0.533. However, other parameters that affect the effective stress concentration factor include: 1) resins other than polyesters, 2) fabric architecture leading to quasi-isotropic material properties of FRP composites, 3) hole diameter-to-width ratios higher than 0.533, 4) laminate thickness larger than ¼ inch and others. Typically, reinforcement patterns in composites leading to high degree of orthotropy need a larger number of test data to account for many failure modes that cannot occur in quasi-isotropic composites. For example, quadriaxial glass fiber polymer composite plates resulted in stress concentration factors of the order of 2.5 (Russo and Zuccarello, 2007). Hence, the proposed stress concentration factor is limited to roving and continuous filament mat construction only, and higher concentration factors may apply if the material is quasi-isotropic. An empirical relationship for complex fabric reinforced composites is recommended after generating an adequate amount of experimental data.

C3.4 Built-Up Members

The designer should be aware that the provisions governing the design of built-up FRP members are in line with the recommendations of AISC steel construction manual for steel members. Here, the adaptation of the AISC provisions is due to a lack of experimental data on built-up pultruded FRP members.

C3.5 Slenderness Limitations

The slenderness limitation for a tension member is intended to minimize damage during transportation and erection, and is based on practical considerations.

The slenderness limitation is not essential for the stability of a tension member and therefore, more liberal criteria are suggested for tension members, including those subject to small compressive forces from transient loads such as earthquake and wind (AISC, 2006). The small compressive forces correspond to F_{cr} equal to 1% to 2% of a typical coupon compressive strength in the longitudinal direction of the member, where, F_{cr} is the elastic Euler buckling stress. The proposed slenderness limitation, i.e. $L/r = 300$, results in a member size that is similar to the sizes being adopted in the current design practices of FRP structural members. Designers are encouraged to conduct additional evaluations if greater accuracies are desired.

References

American Society of Civil Engineers, (1984), Structural Plastics Design Manual, Reston, VA.

American Institute of Steel Construction, Inc. (AISC) (2006), Manual of Steel Construction, Load and Resistance Factor Design, Chicago, IL.

Bataineh, A. T., and GangaRao, H. V. S., “Failure Mode Analysis in Pultruded Fiber Reinforced Plastic Tension Members”, Report, CFC-WVU, August 2009.

Hart-Smith, L.J., “Bolted Joint Analyses for Composite Structures – Current Empirical Methods and Future Scientific Prospects,” *Joining and Repair of Composite Structures, ASTM STP 1455*, K. T. Kedward and H. Kim, Ed.(s), ASTM International, West Conshohocken, PA, 2004.

Russo, A. and Zuccarello, B., “An Accurate Method to Predict the Stress Concentration in Composite Laminates with Circular Hole under Tensile Loading,” *Mechanics of Composite Materials*, Vol 43, No. 4, 2007

C4. DESIGN OF MEMBERS IN COMPRESSION

C4.1 Scope

In practice, the vast majority of compression members are eccentrically loaded. Thus the axial compression is often combined with bending, and such members will be designed according to the provisions established in Chapter 6. Under such provisions, the determination of the member's axial compression strength when the load is assumed to be applied through the centroidal axis of the section is required.

It is to be noted that due to the high strength-to-weight ratio of pultruded structural shapes, elements comprising the cross section become prone to local buckling. It is expected that the design strength of axially compressed pultruded members be governed by local buckling strength of individual elements comprising the cross section. The design equations addressing local buckling (without allowance made for postbuckling strength) limit states have been presented as an integral part of the design strength computations, and thus eliminating the need to establish width-to-thickness ratio limits for local buckling.

C4.2 General Provisions

Pultruded structural members subjected to axial loading should be designed for both strength and serviceability limit states. Equation 4.2-1 ensures that the member's strength based on the limit state of buckling and material strengths is not exceeded. Equation 4.2-3 defines the maximum service load that can be applied on an axially loaded member such that excessive lateral deflection of the compression member will not occur. By limiting the service load deflection to 1/500 of the member length, and assuming additional lateral deflection resulting from geometric eccentricities of the same order as that of the short-term deflection (see. e.g. Winter, 1958), the maximum total deflection under service load is therefore set to 1/250 of the member length. An upper limit of 30% of the component strength based on material compression failure is established to limit creep deformation of stocky components with relatively low slenderness ratios.

C4.3 Slenderness and Effective Length Considerations

C4.3.1 Effective Member Length

The effective member length, L_e is conveniently taken for design purposes as the center-to-center distance between lateral supports. The effective member length may be different in each direction that buckling may occur.

C4.3.2 Effective Length Factor

The effective length factors, K_x and K_y , associated with flexural buckling, account for the end restraint of the member. Realistic values for the effective length factors of an axially loaded compression member whose ends are restrained against translation lie between 0.5 and 1. Thus the use of $K=1$ is conservative. For axially loaded members whose end is not braced against translation, the effective length factor is always greater than 1 and shall be determined by a rational analysis that accounts for the end conditions.

C4.3.4 Compression Member Effective Slenderness Ratio

The effective slenderness ratio, $\frac{KL_e}{r}$, used when calculating the buckling load of a member subjected to

an axial force is limited to a maximum value of $1.4\sqrt{\frac{E_L A_g}{P_D}}$. This maximum slenderness ratio was established by limiting the dead load axial force applied to the member to 20% of its flexural buckling

strength. That is $P_D \leq 0.2 \frac{\pi^2 E_L}{\left(\frac{KL}{r}\right)^2} A_g$. In such a case, the short-term lateral deflection of a compression

member under the dead load will be limited to 1.25 times the initial out-of-straightness.

C4.4 Compression Strength of Commonly Available Sections

Section 4 of the *Standard* addresses only a limited number of commonly produced cross section pultruded shapes that have been tested experimentally. These are in the form of I-shapes, Tees, and equal-leg single angles. Results of tests conducted on channel sections subjected to axial compression have been reported by Hewson (1978), whose experiments included nine sections each of which had a nominal web depth of 0.98 in (25 mm), a nominal flange width 0.98 in (25 mm) and a nominal uniform thickness of 0.098 in (2.5 mm). These sections are much smaller than would be practical for building applications; thus, guidelines for channel sections have not been developed. Furthermore, test results for which material property data have not been well documented in the literature were not considered in the development of Section 4. Guidelines are also provided for calculating the axial compression strength of single-leg angles and concentrically loaded square, rectangular, and circular tube and solid sections. These guidelines have been based on engineering mechanics principles. Compression strength of members with shapes other than those above should be determined by rational analysis or through testing structural prototypes.

Strength limit states for the design of a geometrically symmetric composite pultruded I-shaped member of orthotropic mechanical properties, subjected to a compressive axial load through the centroid involve either instability or material failure. The instability limit states, in turn, involve overall buckling of the member or local buckling of elements of the section. The treatment of overall buckling is similar to the treatment for steel compression members. Local buckling of flanges, webs and stems of T-sections is addressed through equations defining buckling of uniformly compressed orthotropic plates with appropriate boundary conditions, as described in the sections that follow, rather than following the custom in structural steel design of establishing limiting width-thickness ratios.

C4.4.1 Geometrically Symmetric I-Shaped Sections

When an axial load is applied to a slender pultruded member, an overall buckling about the weakest direction occurs. Under such a condition, flexure of the member is accompanied by both a small twist resulting from the non-uniform distribution of the reinforcement throughout the cross section and distortion of the cross section. Equations 4.4-2 and 4.4-3 present the familiar Euler equations for the flexural mode of buckling. Experiments (Zureick and Scott 1997, and Mottram et al. 1998) conducted on pultruded I-shapes in which both the geometry and the material reinforcement throughout the cross sections are symmetric has shown that the Euler formula for flexural buckling correlates well with experimental data. For stocky pultruded sections, local buckling of the flange or the web of an I-shaped

pultruded section occurs prior to the overall buckling, and analytical solutions that accounts for the elastic restraint of various plate elements comprising the cross section have been developed by Zureick and Shih (1998). Numerical results from such solutions correlate well with available experimental data. However, the complexity of these solutions, coupled with the significant efforts required for the calculations, make such solutions very tedious for practical design purposes. A much more practical approach is to consider the flange as a uniformly compressed orthotropic plate simply supported along the loaded edges, simply supported at the flange-web junction, and free at the forth edge. For such a case, equation 4.4-3 provides a reasonable estimate of the buckling strength (Holston, 1970; Zureick and Steffen, 2000). For the case in which buckling is controlled by a slender web, the web is considered to be a uniformly compressed orthotropic plate simply supported at four edges. The buckling strength in this case can be estimated using the equation (Timoshenko and Gere, 1961)

$$F_{crw} = \frac{\left(\frac{\pi^2}{6}\right) \left[\frac{\sqrt{E_L E_T}}{(1 - \nu_{LT} \nu_{TL})} + \frac{\nu_{LT} E_{T,w}}{(1 - \nu_{LT} \nu_{TL})} + 2G_{LT} \right]}{\left(\frac{h}{t_w}\right)^2} \quad (C4.4-1)$$

In equation C4.4-1, the quantity $(1 - \nu_{LT} \nu_{TL})$ which typically ranges from 0.9 to 1 was set to unity for simplicity, and thus the above equation reduces to equation 4.4-4. The ratios of the experimental to predicted buckling strength values of 24 tests on doubly symmetric I-shaped sections under compression are shown in in Figure C4.4.1.

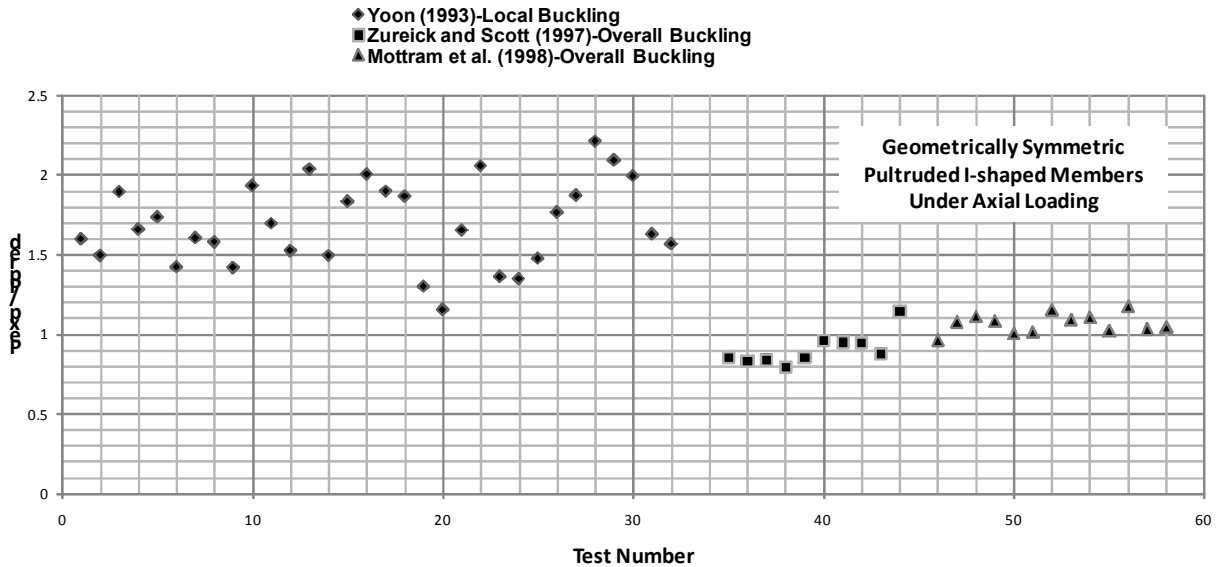

Figure C4.4.1 Experimental vs. predicted strength values of axially compressed pultruded I-shaped sections

C4.4.2 T-Shaped Sections

Design formula and test data for axially compressed T-shaped sections are based on tests conducted at Georgia Institute of Technology(Zureick and Lee, 2004) where pultruded shapes having polyester or vinylester based matrices were examined E-glass polyester and E-glass vinylester T-sections were examined.

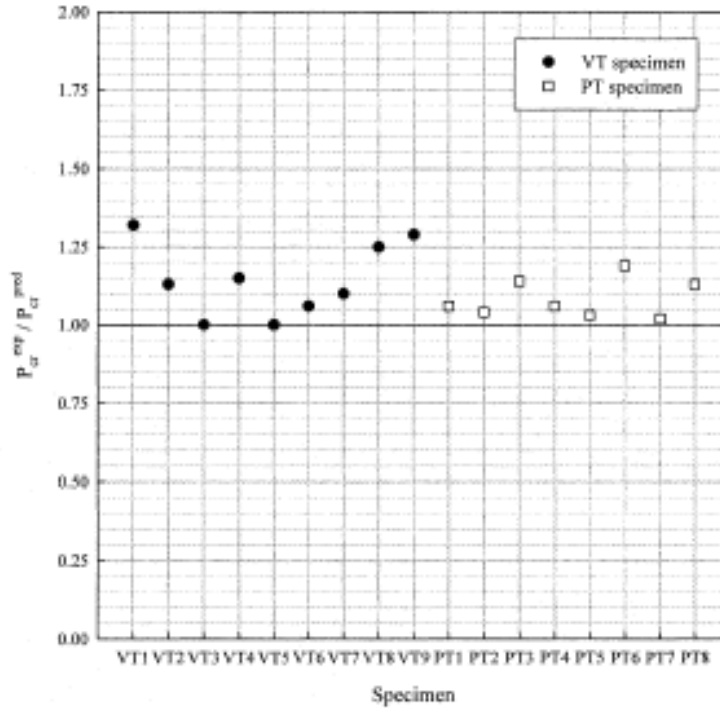

Figure C4.4.2 Experimental vs. computed strength values of axially compressed T-shaped pultruded members

C4.4.3 Single Angle Sections with Equal Legs

Experimental data regarding the axial strength of equal-leg single pultruded angles have been published by Zureick and Steffen (2000). They showed that for an axially loaded equal-leg angle whose legs are identically reinforced such that the material properties are orthotropic, there are two independent modes of buckling: overall flexure about the geometric axis perpendicular to the geometric axis of symmetry of the single angle and overall torsion accompanied by flexure about the geometric axis of symmetry. They also concluded that when $E_{LT}/G_{LT} < 20$ the flexural-torsional buckling load is less than 10% of the torsional buckling load. Thus, the following torsional buckling load formula

$$P_{ez} = \left[\frac{G_{LT}}{(b/t)^2} + \frac{\pi^2 E_L}{12(1-\nu_{LT}\nu_{TL})(K_z L_z / t)^2} \right] A_g \quad (C4.4-2)$$

is sufficient for determining the flexural-torsional buckling strength.

Zureick and Steffen (2000) noted that Equation C4.4-2 results in values within 1% of those obtained from the solution of the governing differential equation of a uniformly compressed orthotropic plate simply supported along the uniformly loaded edges, simply supported at one unloaded edge, and free at the other edge. Such conditions closely model the local buckling behavior of an equal-leg compressed angle, since at buckling both legs buckle simultaneously and neither of the legs is able to restrain the other. Thus the leg plate junction can be regarded as a simple support when mathematically modeling the problem. Since both the local buckling strength and torsional buckling strength are close to each other, the use of equation C4.4-2 is sufficient from a practical point of view to determine the buckling strength of a pultruded single angle under compression. Zureick and Steffen (2000) also noted that for virtually all practical angle sizes with realistic lengths, the second term of equation C4.4-2 is negligible when compared to the first term. On this basis, equation C4.4-2 was further simplified, without losing accuracy, to the form

$$P_{ez} = \left[\frac{G_{LT}}{(b/t)^2} \right] A_g \quad (C4.4-3)$$

which provides the basis for the average critical stress, F_{crfb} , given in equation (4.4-11) of the Standard. Figure C4.4-2 shows the ratio of the experimental buckling loads to those predicted using the equations in the specification.

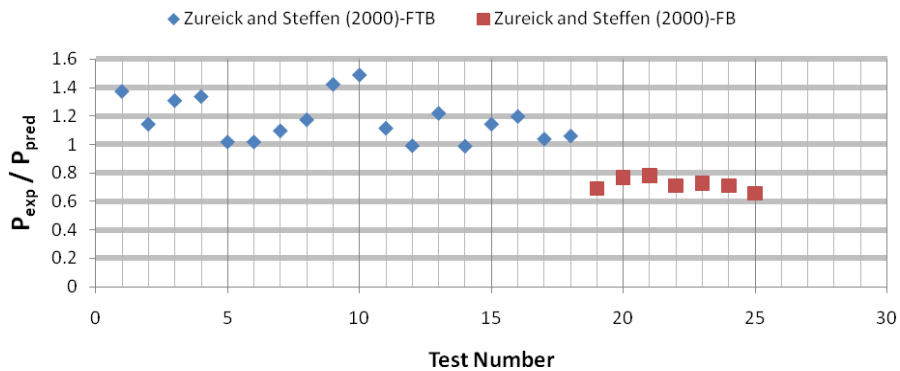

Figure C.4.4.3 Experimental vs. predicted strength values of axially compressed single angle sections with equal legs

C4.4.5 Square and Rectangular Tube Sections

Experimental data associated with the compression strength of square tube members were published by Zureick and Scott (1997).

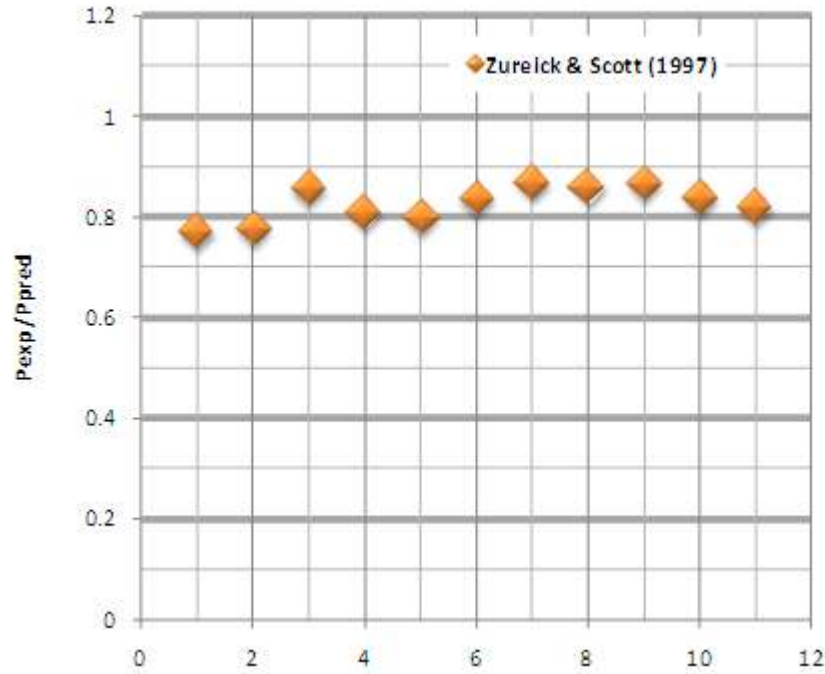

Figure C4.4.5 Experimental vs. predicted strength values of axially compressed square box pultruded sections.

C4.4.6. Circular Tube Sections

An expression for estimating the average local buckling stress of an orthotropic cylinder subjected to axial compression was derived by Dow and Rosen (1966) in the form:

$$F_{cr} = \frac{\kappa}{\left(\frac{R}{t}\right)} \sqrt{\frac{E_L E_T}{3(1-\nu_{LT}\nu_{TL})}} \quad (C4.4-4)$$

where

$$\kappa = \sqrt{\frac{2G_{LT}}{\sqrt{E_L E_T}} \left[1 + \sqrt{\nu_{LT}\nu_{TL}}\right]} \leq 1.$$

The equations of Dow et al. (1966) were rearranged, combined together, and then simplified by replacing the terms $(1-\nu_{LT}\nu_{TL})$ and $\left[1 + \sqrt{\nu_{LT}\nu_{TL}}\right]$ with 1.

C4.5 Compression Strength for Members with Other Cross-Sections

Design equations and tests data associated with axially compressed pultruded members having cross sections not covered in Section 4.4, the design should be based on a combination of analytical or computational solutions coupled with physical full scale tests of the component under consideration.

C4.6 Compressive Strength for Built-up Members

At present, there is no experimental data to support the development of design equations related to built-up sections. Compression strength of built-up members should be determined by rational analysis (Timoshenko and Gere, 1961) or through testing structural prototypes.

References

- Holston, A., (1970), "Buckling of Orthotropic Plates with One Free Edge", *AIAA*, Vol. 8, No. 7, pp. 1352-1354.
- Mottram, J.T., Brown, N.D. and Anderson, D. (2003). 'Physical testing for concentrically loaded columns of pultruded glass fibre reinforced plastic profile', *Structures and Buildings*, 156 2, 2003, 205-219.
- Dow, Norris F., and Rosen, Walter, B. (1966). "Structural Efficiency of Orthotropic Cylindrical Shells Subjected to Axial Compression," *AIAA Journal*, Vol.4, No. 3, pp.481-485.
- Hewson, P.J. (1978), "Buckling of Pultruded Glass Fibre-Reinforced Channel Sections", *Composites*, vol. 9, no. 1, 1978, pp. 56-60
- Timoshenko, S. P. and Gere J. M. (1961). "Theory of Elastic Stability," McGraw-Hill Book Company, Second Edition, New York, Toronto, London.
- Yoon, Soon Jong (1993). "Local Buckling of Pultruded I-Shape Columns," A thesis presented to the academic faculty in partial fulfillment of the requirements for the degree Doctor of Philosophy in Civil Engineering, Georgia Institute of Technology, Atlanta, Georgia.
- Winter, George (1958). "Lateral Bracing of Columns and Beams" *Journal of the structural Division*,
- Zureick, A. and Scott, D. (1997). 'Short-term behavior and design of fiber-reinforced polymeric slender members under axial compression,' *J. Composites for Construction*, ASCE, 1 4, 1997, 140-149.
- Zureick, A., and Steffen, R. (2000) "Behavior and Design of Concentrically Loaded Pultruded Angle Struts," *ASCE Journal of Structural Engineering*, Vol. 126, No. 3, March, pp. 406-416.
- Zureick, A. and Shih, B. (1998). "Local Buckling of Fiber-Reinforced Polymeric Structural Members Under Linearly-Varying Edge Loading, Part I-Theoretical Formulation," *Composite Structures*, Vol.41, pp. 79-86.
- Zureick A. and Lee S. (2004). " Behavior and Design of Pultruded T-Shaped Structural Members Under Compression, Georgia Institute of Technology, School of Civil and Environmental Engineering, SEMM Report No. 04-4.

C5. DESIGN OF MEMBERS FOR FLEXURE & SHEAR

C5.1 Scope

The provisions presented in this chapter apply to both homogenous and non-homogenous pultruded members. A non-homogeneous pultruded member is one in which the properties of the flange(s) are different from the properties of the web(s). Where necessary these properties are identified by a subscript “*f*” for flange and “*w*” for web.

The provisions of this chapter also apply to built-up members, assuming that structural details are developed to ensure that the members remain intact so that individual pultruded members comprising the built-up member do not buckle due to laterally-torsional instability when the member is loaded to its nominal flexural strength, M_n .

This chapter applies to members subjected to transverse loads only. For members subjected to combined loads see Chapter 6.

C5.2 Design of Members for Flexure

Equations are presented for calculating the nominal flexural strength of a non-homogenous member using the mechanics of composite members approach (Gere and Timoshenko, 1997, Section 6.2). As an alternative to these equations the transformed section method may be used (see Gere and Timoshenko, 1997, Section 6.3). The procedure for using the transformed section approach is as follows:

Transform the average characteristic longitudinal properties to those of the web,

$$n = \frac{E_{L,f}}{E_{L,w}} \quad (C5.2-1)$$

$$M_n = \min \left(\frac{F_{L,f} \left(I_f + \frac{I}{n} I_w \right)}{y_f}, \frac{F_{L,w} (n I_f + I_w)}{y_w} \right) \quad (C5.2-2a)$$

gives,

$$M_n = \min \left(\frac{F_{L,f} (n I_f + I_w)}{n y_f}, \frac{F_{L,w} (n I_f + I_w)}{y_w} \right) \quad (C5.2-2b)$$

which simplifies to,

$$M_n = \min \left(\frac{F_{L,f} I_{tr}}{n y_f}, \frac{F_{L,w} I_{tr}}{y_w} \right) \quad (C5.2-2c)$$

In order to provide closed form equations for determining the nominal flexural strength of a non-homogeneous member in which the longitudinal moduli in tension and compression may be different from each other in the flange(s) or the web(s), respectively, the minimum (between compression and tension) characteristic longitudinal modulus of the flange(s) and the minimum (between compression and tension) characteristic longitudinal modulus of the web(s) are used throughout this chapter, since the longitudinal moduli in tension and compression of elements of pultruded members do not vary significantly. If this approximation is not made, the determination of the nominal flexural strength of a member needs to be determined using an iterative procedure that is used for bi-modular members that is not conducive to design calculations.

C5.2.2 Nominal Strength of Members due to Material Rupture

Non-homogeneous members have different strength properties in their web(s) and flange(s), which means that locations with the highest stresses in the web(s) and flange(s) need to be checked for rupture due to flexure. Although the strains are assumed to be linearly varying through the cross member, the stresses may be discontinuous at the flange-web intersections in a non-homogeneous member. Likewise, the strengths of the web and flange may be different. Therefore, non-homogeneous members must be checked for rupture at both the extreme fiber of the flange, and the extreme fiber of the web.

C5.2.3 Nominal Strength of Members due to Local Instability

Local instability occurs when individual elements of a member buckle in-plane due to compressive stresses. The failure mode in which the flange in compression buckles in a in flexure has been observed experimentally by several researchers including Bank *et al.* (1994), Lopez-Anido *et al.* (1996), and Qiao and Zou (2002).

In all local buckling equations provided in this standard the term $(1 - \nu_L \nu_T)$ that typically appears in plate buckling equations has been set to 1.0 and therefore does not appear in the equations as would be expected. This approximation is appropriate for glass fiber reinforced pultruded materials for which $E_L/E_T \leq 5$ and for which this standard applies and may not be appropriate for more highly anisotropic materials for which $E_L/E_T \gg 5$. For local buckling equations including the $(1 - \nu_L \nu_T)$ term see Kollár (2003) and Bank (2006). Sensitivity studies showing the negligible effect of the approximations made in simplifying the equations developed by Kollár can be found in McCarthy (2009) and McCarthy and Bank (2010).

All local buckling equations in Section 5.2.3 assume an element aspect ratio, a/b , of 4 or greater, where a is the length of the unloaded edge parallel and b is the width of the loaded edge. This produces the most conservative buckling coefficients because the element is allowed to assume many buckle half-wavelengths in the direction of the compressive stress. If a situation arises where the plate aspect ratio is less than 4, which will only occur for very short beams, the designer may want to consider increases in the critical buckling stress according to Kollár and Springer (2003, p. 123 – 125).

Although all elements of a member, including the flange(s) and web(s), must be checked for local instability, in open members, the flange will govern in most cases, especially for “I” shapes bent about their strong axis. This is because flanges of “I” members are only restrained at one edge compared to the web which is restrained at both edges. In addition the flange is subjected to uniform compressive stress while the web is subjected to linearly varying compressive axial stress along only half of its depth.

For I-shaped profiles, both the Structural Plastics Design Manual (ASCE, 1984) and the EUROCOMP Design Code (Clarke, 1996) recommend that the elastically restrained edges be assumed to be simply-

supported. This is known to be an overly conservative assumption. Experimental tests on both pultruded beams and columns (where local flange buckling also is critical) clearly show that the local buckling stress is significantly higher than that predicted by the free/simply-supported assumption (Bank *et al.*, 1995; Qiao *et al.*, 2001, Mottram, 2004). In addition, it is also well-known that the flange buckling load is lower than that predicted by assuming that the restraining web provides a fixed edge condition (Bank *et al.*, 1995). An approximate method to obtain closed-form equations for the buckling load for a free and rotationally restrained orthotropic plate was proposed by Kollár (2002). Kollár subsequently extended this work to give closed form equations for buckling of many different thin-walled members with orthotropic walls (Kollár, 2003), which is the source of the equations in section 5.2.3.

Several additional assumptions are made to simplify the flange local buckling equations. Firstly, elements with their edges parallel to the neutral plane (i.e., flanges in a member bent about its strong axis and webs in a member bent about its weak axis bending) are assumed to be subjected to uniform compression throughout the thickness (which is “thin”) of the element, although the stress is always varying under flexure. Secondly, for flanges in a member bent about its weak axis, the stress distribution is assumed to be uniform when it actually varies linearly. In reality, in I members, the portion of the flange in compression is subjected to a linearly varying stress from a maximum on the free edge to zero at the neutral axis location (web). For single channels, the neutral axis passes through the flanges and therefore they are subjected to compressive and tensile linearly varying stress. These assumptions are conservative.

Local web buckling may control for rectangular box members with slender webs. A closed-form expression to predict the buckling stress of the web when restrained by the top and bottom flanges and loaded with a linearly varying stress is not currently available. As a conservative approximation, the buckling stress equations for a web simply supported at the flanges and subjected to a linearly varying axial stress is used. For the stems of tee-profiles, the stress is conservatively approximated to be uniform in the web to account for the situation when the free end of the web is subjected to compressive stress.

Increasing the thickness of web-flange junction fillet region has been shown (Bank *et al.*, 1994) to increase the rotational stiffness of the junction and hence the buckling stress in the flange. There are no analytical equations to determine the exact increased capacity gained by thickening the web-flange junction. Another approach investigated by Turvey (2006) has been to bond longitudinal FRP stiffeners along the free edges of flanges to increase the local buckling resistance.

In order to prevent local buckling of a member the elements in compression need to be prevented from distorting out of plane. This is achieved by attaching the elements in compression to a stiff member. The attachment must be continuous or at spacings of less than the buckle half wavelength. Detailed equations for calculating the buckle half wavelength for the buckling equations presented in this section can be found in Kollár (2003) and Bank (2006). In lieu of calculating the buckle half wavelength the standard recommends the conservative value of one half the width of the element in compression.

C5.2.4 Nominal Strength of Members due to Lateral-Torsional Buckling

Lateral-torsional instability will occur when the member is not sufficiently braced against lateral displacement and rotation of the cross section. This failure mode has been observed by several researchers including Mottram (1992) and Brooks and Turvey (1995). It is generally accepted that the well-known equation that is used for isotropic cross sections, equation 5.2.4-1, can be used for conventional pultruded I-shaped profiles provided the appropriate values of the flexural, torsional and warping stiffness are used in the equations. Inclusion of the effects of shear deformation on lateral-torsional buckling of conventional pultruded profiles is small and, as shown by Roberts (2002), can

generally be neglected. Sensitivity studies showing the significance of the flexural, torsional and warping stiffnesses on the lateral-torsional buckling equations can be found in McCarthy (2009).

C_b is a coefficient that accounts for the moment distribution along the unbraced portion of the beam taken from AISC (2005, p 16.1-270). Table C5.1 provides some common values for C_b .

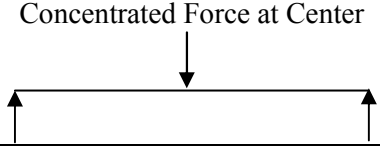
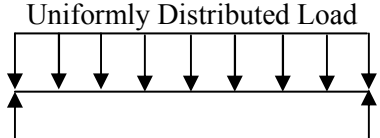
| Table C5.1 Values for C_b for Simply Supported Beams Laterally Braced on Each End | | |
|---|----------------------------|-------------|
| Load Case | Lateral Bracing Along Span | |
| | None | At Midpoint |
| Concentrated Force at Center  | 1.32 | 1.67 |
| Uniformly Distributed Load  | 1.14 | 1.30 |

For singly-symmetric members such as channels and angles little experimental data is available for pultruded profiles. Use of appropriate equations for isotropic metallic members is recommended at this time with substitution of the orthotropic material properties of the pultruded materials in the equations (Razzaq *et al.*, 1996).

C5.3 Design of Members for Shear

C5.3.3 Resistance of Members to Web Shear Buckling

At cross sections of highest shear force, typically at supports and concentrated force points, the web may buckle in shear. Equations 5.3.3-2 through 5.3.3-5, used to calculate the critical shear buckling stress for a web restrained on both of its edges (ASCE, 1984; Kollár, 2003) are a function of the shear buckling coefficient, k_{LT} . For pultruded members, equation 5.3.3-2 will typically govern because the expression

$$2G_{LT} + E_{T,w} \nu_{LT} \leq \sqrt{E_{L,w} E_{T,w}} \text{ will usually be satisfied.}$$

In order to prevent shear buckling from occurring, if the web is not sufficiently stiff, vertical stiffeners may be provided along the length of the beam where the shear force will cause the web to buckle in shear. The buckled half wavelength for a stiffened web loaded in shear, s_w , is given by Timoshenko and Gere (1961, p. 383) as $s_w = d_w \sqrt{1.5}$. To be conservative, Section 5.3.3 requires that stiffeners be located at distances of d_w or less along the length of the beam where the shear force is large enough to cause the web to buckle, even though the buckled half wavelength will always be longer than d_w .

If stiffeners are required then they should be designed for the minimum flexural rigidity specified in equation 5.3.3-6. This provision is based on isotropic material property assumptions and is taken from the Structural Plastics Design Manual (ASCE, 1984).

C5.4 Design of Members for Concentrated Forces

C5.4.1 Design Basis

This section applies to concentrated forces applied in the plane of the web and to concentrated forces applied perpendicular to flanges that cause local transverse bending of flange elements. Since very limited test data is available for failure of members due to local concentrated forces and since these failure modes are especially complex and depend on three dimensional stress states, equation 5.4.1-2 adds additional conservativeness to the design equations provided in this section.

C5.4.3 Nominal Strength of Members due to Web Crippling

Equation 5.4.3-1 is based on a series of web crippling experiments and numerical studies performed on pultruded I beams conducted at the University of Wisconsin. (Borowicz and Bank, 2010). Crippling failure of the web is primarily due to an interlamina shear failure that initiates directly under the location of the concentrated force and that propagates along the web/flange junction. Testing has shown that the extent of the shear failure is a function of the length and thickness of a bearing plate (of pultruded material) that is used between the element applying the load and the top flange of the beam. It has been shown that a bearing plate longer than 4 inches (102 mm) does not increase the crippling load (Borowicz and Bank, 2010). Pultruded beams of depth greater than 12 inches (305 mm) have been shown to exhibit a greater influence of web compression instability and the strength is not predicted with sufficient accuracy by equation 5.4.3-1. Therefore vertical stiffeners, positioned directly under the location of the concentrated force, are required for beam the depths greater than 12 inches (305 mm). Test data for both crippling and compression buckling are detailed in Borowicz (2010).

C5.4.4 Nominal Strength of Members due to Web Compression Buckling

A web may buckle in the vertical plane, as if it were a wide but slender column. In equation 5.4.4-2 (Kollár, 2003) the web is modeled as a simply supported plate loaded with a uniform compressive load applied over an effective length, l_{eff} . Figure C5.4-1 shows different examples of the effective web compression buckling length, l_{eff} .

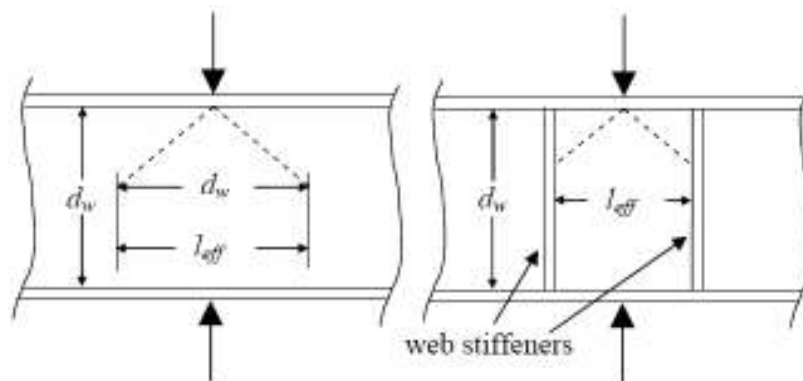

Figure C5.4-1 – Effective web compression buckling length, l_{eff}

C5.5 Design for Copes, Notches, Holes and Openings

C5.5.1 Copes, Notches, Holes and Web Openings in the Flange or Web

Flange notches and copes affect both the strength and the stability of flanges. The designer is cautioned that notches in flanges in orthotropic pultruded materials with lower transverse strengths than conventional materials, can lead to local failure of the member. Typically, locations of notches and copes need to be reinforced with doubler plates.

Web openings affect both the strength and the stability of the web. The designer is cautioned that openings in webs in orthotropic pultruded materials with lower transverse strengths than conventional materials, can lead to local failure of the member. Designers should especially be concerned with web openings in regions having the largest shear forces, such as near supports. Because of a lack of experimental data on the reduced strength or stability of a member due to web openings, it is recommended that they be avoided unless shown to be justified by strength testing.

C5.6 Design of Flexural Members For Serviceability

Timoshenko shear deformation beam theory is used to determine the deflection of a pultruded beam. This is the procedure recommended by the Structural Plastic Design Manual (1984) and the EUROCOMP Design Code (Clarke, 1996) and numerous researchers (Bank, 1989; Turvey, 1999; Qiao *et al* ,1998). The use of shear deformation beam theory is especially important in pultruded beams because of the lower (compared to steel) longitudinal modulus (leading to beams with short spans) and the higher (up to approximately 5 times higher than steel for glass FRP) E_L/G_{LT} ratios due to the lower (compared to steel) shear modulus of pultruded materials (Bank, 1989). When shear deformation is considered, according to Section 2.6, equation C5.6-1 can be used to determine deflections that include shear effects:

$$\delta_u = (\delta_u)_b + (\delta_u)_s = \frac{f_1(z)}{E_b I} + \frac{f_2(z)}{G_b A} \quad (\text{C5.6-1})$$

$(\delta_u)_b$ = Deflection due to bending deformation, in. (mm)

$(\delta_u)_s$ = Deflection due to shear deformation, in. (mm)

E_b = Full-section flexural modulus, ksi (MPa)

G_b = Full-section shear modulus, ksi (MPa)

I = Moment of Inertia of the cross-section, in⁴ (mm⁴)

A = Cross-sectional area, in.² (mm²)

$f_1(z), f_2(z)$ = Functions that depend on the loading and boundary conditions. Table C5.2 gives common values (from Bank, 2006).

E_b is the full section flexural modulus which may be determined by experimental testing (Bank 1989). G_b is the full section shear modulus, which may be determined by experimental testing (Bank 1989).

| Table C5.2 Values for $f_1(z)$ and $f_2(z)$ in Equation C5.6-1 ^[a] | | | | |
|---|--|---|---------------------------------------|--|
| | Simply Supported Beam | | Cantilever Beam | |
| | δ_{max} at center ($z = L/2$) | | δ_{max} at tip ($z = L$) | |
| | Uniformly Distributed Load (w) | Concentrated force at Center (P) ^[b] | Uniformly Distributed Load (w) | Concentrated force at Free End (P) |
| $f_1(z)$ | $\frac{w}{24}(z^4 - Lz^3 + L^3z)$ | $\frac{P}{48}(3Lz^2 - z^4)$ | $\frac{w}{24}(z^4 - 4Lz^3 + 6L^2z^2)$ | $\frac{P}{6}(3Lz^2 - z^3)$ |
| $f_2(z)$ | $\frac{w}{2}(Lz - z^2)$ | $\frac{P}{2}(z)$ | $\frac{w}{2}(2Lz - z^2)$ | $P(z)$ |
| $f_1(\delta_{max})$ | $\frac{5wL^4}{384}$ | $\frac{PL^3}{48}$ | $\frac{wL^4}{8}$ | $\frac{PL^3}{3}$ |
| $f_2(\delta_{max})$ | $\frac{wL^2}{8}$ | $\frac{PL}{4}$ | $\frac{wL^2}{2}$ | PL |
| [a] Deflections are positive in the direction of the applied load, z is measured along the length of the beam | | | | |
| [b] For $0 < z < L/2$ | | | | |

REFERENCES

AISC (2005), *Specification for Structural Steel Buildings and Commentary*, ANSI/AISC 360-05, American Institute of Steel Construction, Chicago.

ASCE (1984), *Structural Plastics Design Manual*, ASCE Manuals and Reports on Engineering Practice 63, American Society of Civil Engineers, Reston, VA.

Bank, L. C. (1989), "Flexural and Shear Moduli of Full-Section Fiber Reinforced Plastic (FRP) Pultruded Beams," *ASTM Journal of Testing and Evaluation*, Vol. 17, No. 1, pp. 40-45.

Bank, L. C., (2006), *Composites for Construction*, John Wiley and Sons, New York, NY.

Bank, L. C., Gentry, T.R. and Nadipelli, M., (1994), "Local Buckling of Pultruded FRP Beams – Analysis and Design," *Proceedings of the 49th Annual Conference, Composites Institute*, February 7-9, 1994, Cincinnati, OH, The Society of Plastics Industry, Inc., Session 8-D, p. 6.

Bank, L. C., Yin, J., and Nadipelli, M., (1995), "Local Buckling of Pultruded Beams: Nonlinearity, Anisotropy and Inhomogeneity," *Construction and Building Materials*, Vol. 9, No. 6, pp. 325-331.

Borowicz, D.T., (2010), "Web Failure in Pultruded Beams due to Concentrated Loads," PhD Thesis, University of Wisconsin-Madison. (in preparation).

Borowicz, D.T., and Bank, L.C., (2010), "Behavior of Pultruded Fiber-Reinforced Polymer (FRP) Beams Subjected to Concentrated Loads in the Plane of the Web," accepted for publication in the *ASCE Journal of Composites for Construction*.

Brooks, R. J. and Turvey, G.J., (1995), "Lateral Buckling of Pultruded GRP I-Section Cantilevers," *Composite Structures*, Vol. 32, pp. 203-216.

Clarke, J. L., (Ed.) (1996), *Structural Design of Polymer Composites, Eurocomp Design Code and Handbook* (ed. J Clarke), E&FN Spon, London.

EN 13706-2, (2002), *Reinforced Plastics Composites – Specifications for Pultruded Profiles – Part 2: Method of Test and General Requirements*, BSI Standards Policy and Strategy Committee.

Gere, J. M. and Timoshenko, S. P., (1997), *Mechanics of Materials*, 4th ed., PWS Pub. Co., Boston, MA.

Kollár, L.P. (2002), “Buckling of Unidirectionally Loaded Composite Plates with One Free and One Rotationally restrained Unloaded Edge,” *Journal of Structural Engineering*, Vol. 128, No. 9, pp. 1202-1211.

Kollár, L.P. (2003), “Local Buckling of Fiber Reinforced Plastic Composite Structural Members with Open and Closed Cross Sections,” *Journal of Structural Engineering*, Vol. 129, No. 11, pp. 1503-1513.

Kollár, L.P. and Springer, G. S., (2003), *Mechanics of Composite Structures*, Cambridge University Press, Cambridge, United Kingdom.

Lopez-Anido, R., Bendidi, R., GangaRao, H.V.S. and Al-Megdad, M., (1996), “Local Buckling Experiments on Pultruded Composite Beams,” *Proceedings of the 4th Materials Engineering Conference*, ASCE, NY, Vol. 2, pp. 914-923.

McCarthy, M.J., (2009), “Professional Factors for an LRFD Standard for Pultruded Beams” University of Wisconsin-Madison, MS Thesis.

McCarthy, M.J., and Bank, L.C., (2010), “Sensitivity Studies on Local Flange Buckling Equation for Pultruded Beams and Columns,” *Proceedings of CICE 2010*, Beijing, China, Sept 27-29, 2010.

Mottram, J.T., (1992), “Lateral-torsional Buckling of a Pultruded I-beam,” *Composite Structures*, Vol. 23, No. 2, pp. 81-93.

Mottram, J. T., (2004), “Determination of Critical Load for Flange Buckling in Concentrically Loaded Pultruded Columns,” *Composites, Part B: Engineering*, Vol. 35, No. 1, pp. 35-47.

Qiao, P., Davalos, J.F. and Barbero, E.J., (1998), “Design optimization of fiber reinforced plastic composite shapes,” *Journal of Composite Materials*, Vol. 32, No. 2, pp. 177-196.

Qiao, P., Davalos, J. F. and Wang, J., (2001), “Local Buckling of Composite FRP Shapes by Discrete Plate Analysis,” *Journal of Structural Engineering*, Vol. 127, No. 3, pp. 245-255.

Qiao P., and Zou, G. (2002), “Local Buckling of FRP Structural Shapes – Explicit Analysis,” *Proceedings of the Third International Conference on Composites in Infrastructure (ICCI)*, June 10–12, San Francisco, CA, CD-ROM.

Razzaq, Z., Prabhakaran, R., and Sirjani, M. M. (1996), “Load and Resistance Factor Design (LRFD) Approach for Reinforced-Plastic Channel Beam Buckling,” *Composites: Part B*, Vol. 27B, pp. 361-369.

Roberts, T. M. (2002), “Influence of Shear Deformation on Buckling of Pultruded Fiber reinforced Plastic I-profiles,” *Journal of Composites for Construction*, Vol. 6, pp. 241-248.

Salmon, C. G., and Johnson, J. E., (1996), *Steel Structures: Design and Behavior*, 4th ed., Harper Collins, New York, NY.

Timoshenko, S., and Gere, J. (1961), *Theory of Elastic Stability*, 2nd ed., McGraw-Hill, New York, NY.

Turvey, G.J., (1999), "Flexure of pultruded beams with semi-rigid end connections," *Composite Structures*, Vol. 47, pp. 571-580.

Turvey, G.J., (2006), 'Structural analysis of CFRP-plated pultruded GRP beams,' *Structures and Buildings*, Vol, 159, No. 2, pp, 65-75.

C6. DESIGN OF MEMBERS UNDER COMBINED FORCES & TORSION

C6.1 Scope

The provisions of this chapter cover the design of doubly symmetric members (namely I-shapes, back-to-back channels, square and rectangular tubes) of constant cross section along the member length (prismatic) under axial force and bending about one or both axes of symmetry. This chapter also covers prismatic singly symmetric members (namely T-shapes, back-to-back angles) subject to axial force and flexure about the strong axis only. If the transverse loads on a member do not pass through the center of gravity of the cross section, the member must be designed for torsion as well. The provisions of Section 6.2 are restricted to the cross sections covered by the provisions of Chapters 4 and 5. In addition, the provisions of Section 6.3 cover the design of doubly symmetric members subjected to torsion, flexure and/or axial loads. These provisions do not cover the serviceability limit state checks. The Engineer needs to compute induced displacements and other serviceability issues such as frequency responses using rational analysis. There are many cross sections that are unsymmetrical and the interaction equations suggested in Chapter 6 may not be appropriate without appropriate modification; however, the linear interaction used in this Chapter may be used for the design of unsymmetrical sections.

For additional information torsional stress responses, refer to Chapter 5 of the ASCE Structural Plastics Design Manual (1984).

C6.2 Symmetric Members Subject to Bending and Axial Load

Equations 6.2-1 through 6.2-4 are linear interaction equations under axial load and flexure. The reason for selecting a linear equation is that it provides a more conservative design than a parabolic equation which is used for members with ductile failure while the stress-strain response of pultruded FRP composites is linear up to failure. Equations 6.2-1 through 6.2-4 are a modification of AISC (2006) Equations H1-1. Equations referring to both major axis and minor axis are provided to eliminate any confusion for designers. The nominal axial compressive strength P_n is determined from the provisions of Chapter 4 which include the limit states of both stocky and slender columns. Similarly, the nominal axial tension strength P_n is determined from the provisions of Chapter 3. The nominal flexural strength M_n is controlled by the design provisions of Chapter 5 which includes the limit states of flexural members. The required axial compressive and tensile strength P_u and the required flexural strength M_n are determined using elastic linear analysis. For symmetric members under axial force and strong axis bending, the weak axis bending term is dropped from Equations 6.2-1 and 6.2-2, with the modified equations shown as Equations 6.2-3 and 6.2-4.

C6.3 Doubly Symmetric Members under Torsion and Combined Torsion, Flexure and/or Axial Force

C6.3.1 Torsional Strength of Circular and Rectangular Hollow Tubes

Circular and rectangular hollow tubes are far more torsionally efficient sections than open sections such as I-shapes. Therefore, it is highly desirable to use closed sections in design situations where torsional moments are significant. In closed sections; stresses resulting from

restrained warping are insignificant and are neglected with the exception of short members. On the other hand, bending and shear stresses due to restrained warping (depending on connection details) must be considered for the design of open sections under torsion.

Torsion in closed sections is assumed to be resisted primarily by pure shear stress or St. Venant shear stress. The shear stress distribution is assumed to be uniform along the length of the wall of the cross section. The torsional moment is equal to the product of the shear stress F_n and the torsional constant (polar moment of inertia of the geometric cross section) when strength governs the design.

$$T_n = \lambda \Phi F_n \hat{J} \quad (C6.3-1a)$$

When the critical shear stress F_{cr} is reached due to buckling, the nominal torsional design strength (buckling) is related to F_{cr} as given below, and adjusted in accordance with the requirements of Section 2.4:

$$T_n = \lambda \Phi F_{cr} C \quad (C6.3-1b)$$

where,

$$F_n = \gamma G_{LT}$$

γ = nominal coupon specimen shear strain/unit length from the characteristic value of coupon, as defined in ASTM D5379-05

G_{LT} = in-plane shear modulus of elasticity as defined in ASTM D5379-05

\hat{J} = torsional constant (polar moment of inertia) computed as per Equations 6.3-3 through 6.3-5

C = torsional constant to be computed as per Equations 6.3-6 through 6.3-8

Φ = resistance factor for torsion based on rupture data as given in Eq. 6.3-1

λ = time effect factor defined in Table 2.3-1

Based on the extensive testing done by Roberts and Masri (2003), the product of shear strain times the gage length of a specimen subjected to torque divided by the wall thickness in a wide flange beam may be taken as 4.0. Torsional coupon tests of composites made of unidirectional rovings and continuous filament mat were resulting in failure shear strains of 15,000 to 20,000 microstrains (Prachasaree, 2005). For additional information on developing warping constants of rectangular tubes, please refer to Roberts and Al-Ubaidi (2001).

For a cylinder of definite length made of an orthotropic material, an equation for the elastic buckling torsional moment is given by (Vinson and Sierakowski, 1987). It is assumed that the ends of the cylinder are not restrained from rotation. After neglecting the product of Poisson's ratios and the squares of the thickness, the equation for a moderate length cylinder is written as:

$$F_{cr} = \frac{0.260 E_T^{5/8} E_L^{3/8}}{\left(\frac{R}{t}\right)^{5/4} \sqrt{\frac{L}{R}}} \quad (C6.3-2)$$

And the length L must satisfy

$$L \geq \frac{22.36 \sqrt{Rt}}{\left(\frac{E_T}{E_L}\right)^{5/12}} \quad (\text{C6.3-3})$$

For a long cylinder $L > 2R$ (Timoshenko, 1961) made of an orthotropic material, the equation for the elastic buckling stress under torsion is:

$$F_{cr} = \frac{0.236 E_T^{5/8} E_L^{3/8}}{\left(\frac{R}{t}\right)^{3/2}} \quad (\text{C6.3-4})$$

The above equations for orthotropic material are an extension of an equation given by (Timoshenko, 1961) for isotropic materials under torsion.

$$F_{cr} = \frac{E}{3\sqrt{2}(1-\nu^2)^{3/4} \left(\frac{R}{t}\right)^{3/2}} \quad (\text{C6.3-5})$$

Equations (C6.3-2) and (C6.3-4) do not account for initial imperfections. The critical buckling stress values obtained from Equations (C6.3-2) and (C6.3-4) are limited by the in-plane shear strength of the composite as an upper-bound. This limitation is to insure that the limit state of rupture under shear stress is not exceeded.

Closed form beam equations are provided for rectangular shapes under torsion in terms of the material and cross sectional properties. These beam equations are developed for anisotropic materials by Gangarao (2010) based on global torsional buckling of beams under torsion (Timoshenko and Gere, 1961). Local torsional buckling equations are not provided herein, hence designers shall use rational analysis to arrive at local torsional buckling values for various cross sections.

C6.3.2 Rectangular Hollow Tubes Subject to Combined Torsion, Flexure and Axial Force

Equation 6.3-13 combines normal stresses due to bending and axial loads and an elliptic combination of flexural and torsional stresses.

C6.3.3 Design Strength of Open Doubly Symmetric Shapes Subject to Torsion and Combined Forces

This section covers the design of open doubly symmetric shapes not covered by Sections 6.3.1 and 6.3.2. There are four limit states to be considered in the design:

- (a) rupture under normal tensile stress
- (b) crushing under normal compressive stress
- (c) rupture under shear stress
- (d) buckling under axial compressive or shear stresses

Rationale analysis procedures can be used since stress concentration factors under combined stress fields are not available in closed form.

References

American Society of Civil Engineers, (1984), Structural Plastics Design Manual, Reston, VA.

American Institute of Steel Construction, Inc. (AISC) (2006), Manual of Steel Construction, Load and Resistance Factor Design, Chicago, IL.

Prachasaree, W. (2005) "Performance Evaluation of FRP Bridge Deck Under Shear Loads." Dissertation for PhD submitted to the College of Engineering and Mineral Resources, West Virginia University.

Roberts, T.M. and Al-Udaidi, H. (2001) "Influence of Shear Deformation on Restrained Torsional Warping of Pultruded FRP Bars of Open Cross-Section." *Thin-Walled Structures* Volume 39 (2001) pp 395-414.

Roberts, T.M., and Masri, H.M.K.J.A.H. (2003) "Section Properties and Buckling Behavior of Pultruded FRP Profiles." *Journal of Reinforced Plastics and Composites* Volume 22, No. 14/2003 pp 1305.

Timoshenko, S.P., and Gere, J.M., (1961), Theory of Elastic Stability, McGraw-Hill, New York, NY.

Vinson, J.R., and Sierakowski, R.L., (1987), The Behavior of Structures Composed of Composite materials, Martinus Nijhoff Publishers, Dordrecht.

Gangarao, H V S, (2010), Global Torsional Buckling of Anisotropic Beams, CFC-WVU report.

C7. PLATES AND BUILT-UP MEMBERS

C7.1 Scope

The provisions presented in Chapter 7 apply to pultruded plates with orthotropic properties. The provisions apply to homogeneous pultruded plates, and homogeneous or non-homogeneous built-up members. Homogeneous pultruded plates and built-up members are made with the same material type and have constant properties at every point. Non-homogeneous built-up members are made of pultruded plates and components with different material types and stiffnesses.

C7.2 General Provisions

Pultruded plates are planar structural elements whose thickness is small compared to their length and width dimensions. Built-up members consist of pultruded plates and components (sections or profiles) connected together, and include panel-based assemblies, plate girders, shear walls and diaphragms.

The plate material longitudinal direction (pultrusion direction) refers to the direction of motion of the plate through the pultrusion forming die (See Figure C7.2-1). The plate material transverse direction refers to the direction orthogonal to the pultrusion direction. The plate material longitudinal and transverse directions (axes) are the principal material directions (directions of material orthotropy), with both directions in the plane of the plate. The material longitudinal direction corresponds to the axis of greatest stiffness of the plate. It is critical that during initial fabrication the plate product be labeled as to longitudinal and/or transverse directions.

The provisions of Section 7.2 are limited to pultruded plates with a minimum thickness of 1/8 inch and a maximum thickness of 1.0 inch. The provisions of Section 7.2 are limited to pultruded plates with a maximum out-of-plane deflection less than or equal to half of the thickness of the plate. The maximum thickness variation allowed for the pultruded plate is the lower value between 10% of the thickness or 0.050 inches (1.3 mm).

Plates can be supported by a combination of fully or partially restrained supports along two, three or four edges. Two types of fully restrained supports for plates are considered in this specification: a) At a simple edge support, the plate out-of-plane deflections are restricted, but rotations and in-plane displacements are free; and b) At a fixed (clamped or built-in) support, the plate rotations and out-of-plane deflections are restricted, but in-plane displacements are free. Two types of partially restrained supports for plates are considered in this specification: a) At a partially restrained rotational support, the bending moment is proportional to the rotation of the edge, out-of-plane deflections are restricted and in-plane displacements are free; and b) At a partially restrained translational support, the out-of-plane shear force is proportional to the deflection of the edge, rotations and in-plane displacements are free.

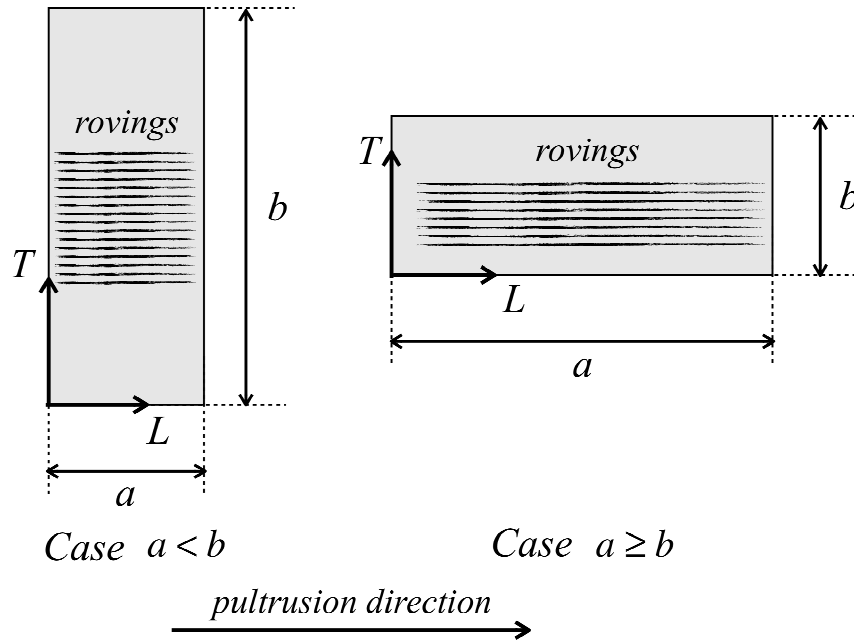

Figure C7.2-1 Principal Material Directions for Pultruded Plates

Nominal design properties must be provided for the material longitudinal (lengthwise) and transverse (crosswise) directions of pultruded plates. Cross-section geometric properties, such as the moment of inertia and the area, must be computed per unit length of plate. Bending moments, in-plane forces and through-the-thickness shear forces must be computed per unit length of plate.

The minimum required mechanical properties for pultruded plates and the corresponding ASTM standard test methods are specified in Table 1.3-2(b). Guidelines for the application of these test methods to pultruded plates including limitations, suggested deviations, specific recommendations and alternative test methods are presented in this commentary. The Standard Guide for Testing Polymer Matrix Composite Materials (ASTM D4762) is the reference technical document for selecting the test methods and measuring the corresponding properties. A summary of the material failure modes for pultruded plates, the corresponding characteristic strength, the applicable ASTM standard test method, and the nominal strength per unit length and is presented in Table C7.2-1.

Table C7.2-1 Material Failure Modes and Test Methods for Pultruded Plates

| Failure mode | Characteristic Strength | ASTM Test Method | Nominal Strength |
|--|-------------------------|-----------------------|------------------|
| Flexural strength | F_L^f, F_T^f | D790 | M_n |
| Compressive strength | F_L^c, F_T^c | D6641 | N_n^c |
| Tensile strength | F_L^t, F_T^t | D638 | N_n^t |
| Open-hole tensile strength | F_L^m, F_T^m | D5766 | N_n^t |
| In-plane shear strength | F_{LT} | D5379 | $N_{LT,n}$ |
| Through-the-thickness shear strength for $t \geq 20$ mm (0.75 in.) | F_L^v, F_T^v | D5379 | V_n |
| Short beam strength ^(a) | F_L^v, F_T^v | D2344 | V_n |
| Pull-through strength per fastener | F^t | D7332- Procedure B | R_n^t |

Note: ^(a) Measurement of a strength parameter related to the through-the-thickness shear strength.

Illustrations of the orthogonal planes of shear loading corresponding to the pultruded plate shear strengths presented in Table C7.2-1 are depicted in Figures C7.2-2, C7.2-3 and C7.2-4.

The planes of shear loading corresponding to in-plane shear strength, F_{LT} , are shown in Figure C7.2-2.

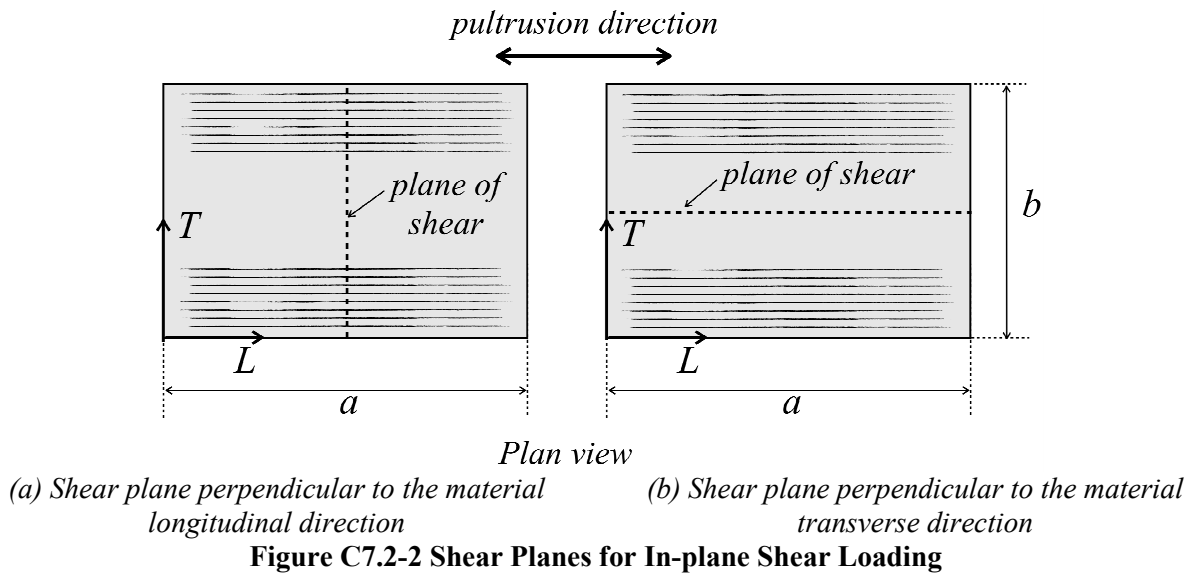

The plane of shear loading corresponding to through-the-thickness shear strength, F_L^v , on a plane perpendicular to the material longitudinal direction is shown in Figure C7.2-3.

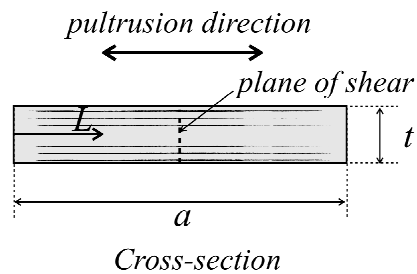

Figure C7.2-3 Shear Plane for Through-the-Thickness Shear Loading Perpendicular to the Material Longitudinal Direction

The plane of shear loading corresponding to through-the-thickness shear strength, F_T^v , on a plane perpendicular to the material transverse direction is shown in Figure C7.2-4.

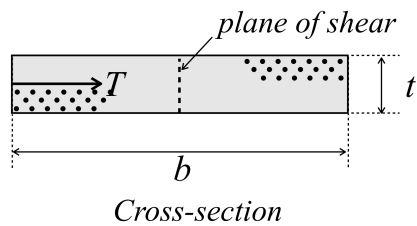

Figure C7.2-4 Shear Plane for Through-the-Thickness Shear Loading Perpendicular to the Material Transverse Direction

Engineering mechanics methods based on the Theory of Plates can be used for accurate computation of bending moments and shear forces (Timoshenko and Woinowsky-Kreiger 1964). Beam equations (Gere and Timoshenko 1997) applied to the effective plate width can be used to compute bending moments and shear forces for one-way plate bending. The strip method (Ugural 1981) can be used to compute bending moments and shear forces for two-way plate bending.

C7.3 Design of Plates Subjected to Flexure

C7.3.1 Nominal Flexural Strength of Plates for One-Way Plate Bending

Rectangular plates subjected to loads applied normal to the planar surface and supported at least on two opposite edges, which comply with the requirements of Section 7.3.1 develop one-way plate bending. The provisions of Section 7.3.1 are limited to pultruded plates with a maximum span length to thickness ratio of 100.

The flexural strength test method (ASTM D790) utilizes a three-point loading system applied to a simply supported beam; the standard specimen span-to-thickness ratio is 16:1. A deviation of ASTM D790 is required for pultruded plate coupons to comply with the span-to-thickness requirements of Section 7.2. An alternative flexural strength test method is ASTM D7264, which has two procedures: a) Three-point loading system utilizing center loading on a simply supported beam, and b) Four-point loading system utilizing two load points equally spaced from their adjacent support points, with a distance between load points of one-half of the support span; the standard specimen span-to-thickness ratio is 32:1 (Berube and Lopez-Anido 2010).

C7.3.2 Nominal Flexural Strength of Plates for Two-Way Plate Bending

Rectangular plates subjected to loads applied normal to the planar surface and supported on three or four edges, which satisfy the requirements set forth in Section 7.3.2, develop two-way plate bending. Plates that do not satisfy these requirements are designed for one-way bending along the shorter span length.

The limits for the geometric aspect ratio (a/b) for rectangular pultruded plates specified in Section 7.3.2 are based on the limits for isotropic plates ($1/2 \leq a/b \leq 2$) modified by the material orthotropy ratio (E_L/E_T). The provisions of Section 7.3.2 are limited to pultruded plates with a maximum span length to thickness ratio of 180.

This specification does not attempt to quantify the effect of interactions between longitudinal and transverse flexural strength. The effects of interactions for two-way plate bending can be evaluated with a qualification test (ASTM D6416). In this test, a square pultruded plate is subjected to two-way plate bending by applying a distributed load. The distributed load is provided using a water-filled bladder (hydromat). The square plate span length to thickness (a/t) ratio is between 10.0 and 30.0, and the support length is 500 mm (19.7 in).

C7.4 Design of Plates Subjected to Through-the-Thickness Shear

C7.4.1 Nominal Shear Strength of Plates for One-Way Plate Bending

Through-the-thickness shear strength is also referred to as out-of-plane shear strength or interlaminar shear strength. To measure through-the-thickness shear strength ASTM D5379 V-notched beam method requires a 20 mm (0.75 in.) thick pultruded plate specimen (See Figures C7.4.1-1 and C7.4.1-2). For pultruded plate specimens less than 20 mm (0.75 in.) thick, ASTM D2344 short beam strength method can be used to measure a strength parameter related to the through-the-thickness shear strength.

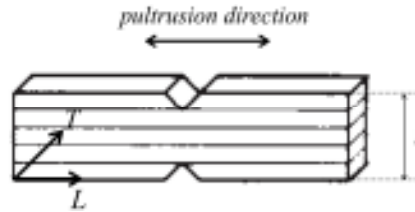

Figure C7.4.1-1 Pultruded Plate V-Notched Beam Specimen for Through-the-Thickness Shear Strength, F_L^v , according to ASTM D5379

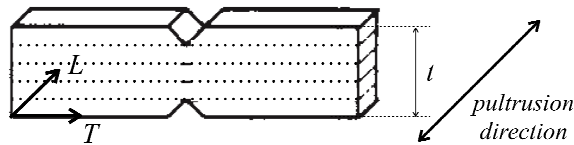

Figure C7.4.1-2 Pultruded Plate V-Notched Beam Specimen for Through-the-Thickness Shear Strength, F_T^v , according to ASTM D5379

C7.4.3 Pull-Through Strength of Plates

Fastener pull-through strength is characterized by the force-versus-displacement response exhibited when a mechanical fastener is pulled through a pultruded plate, with the force applied perpendicular to the plane of the plate. Pull-through loads impart tensile loading on the fastener and out-of-plane compressive loading on the pultruded plate. Plate joints loaded in pull-through may fail in either punching shear at the outer edge of the fastener head or in flexural failure near the bolt hole boundary (Thoppul et al. 2009).

The pull-through strength is obtained in accordance with ASTM D7332-Procedure B corresponding to the first peak load observed in the load–displacement curve, prior to the first significant (greater than 10 %) drop in applied load. Factors that influence the pull-through strength of pultruded plates include the following: hole diameter, fastener diameter, fastener head diameter, clearance hole diameter to fastener hole diameter ratio, fastener diameter to plate thickness ratio, fastener torque, fastener material, countersink angle and depth of countersink.

The provisions of Section 7.4.3 are equivalent to the provisions for tension (through-the-thickness) strength of Section 8.3.2.2 (Clarke 1996).

C7.5 Design of Plates Subjected to In-Plane Tensile Loading

C7.5.1 Nominal Tensile Strength of Plates

Pultruded plates exhibit a notched strength behavior that is not purely brittle. This can be explained due to the various forms of localized matrix cracking and fiber fracture at the maximum stress locations around the hole, which relieve the elastic stress concentration by reducing the local material stiffness (CMH-17 Composite Materials Handbook 2009).

The orthotropic material effective stress concentration factor, k_{ic} , proposed by Hart-Smith (2004), and referenced by Mottram (2010) for pultruded materials, is adopted. This factor is used in the unfilled open-hole strength equation (C8.3.2-1) as part of the provisions for bolted connection design.

The open-hole effective stress concentration factor in the longitudinal direction is:

$$k_L = \frac{F_L^t}{F_L^{tg}} \left(1 - \frac{d_n}{w} \right) = \frac{F_L^t}{F_L^m} \quad (C7.5.1-1)$$

where

F_L^{tg} = Characteristic open-hole gross-section longitudinal tensile strength

F_L^m = Characteristic open-hole net-section longitudinal tensile strength

F_L^t = Characteristic longitudinal tensile strength

w = Width of the plate at the plane of failure

d_n = Diameter of an unfilled hole

The open-hole effective stress concentration factor in the transverse direction is:

$$k_T = \frac{F_T^t}{F_T^{tg}} \left(1 - \frac{d_n}{w} \right) = \frac{F_T^t}{F_T^m} \quad (C7.5.1-2)$$

where

F_T^{tg} = Characteristic open-hole gross-section longitudinal tensile strength

F_T^m = Characteristic open-hole net-section longitudinal tensile strength

F_T^t = Characteristic longitudinal tensile strength

Open-hole effective stress concentration factors in the material longitudinal and transverse directions were computed by Mottram (2010) based on the open-hole tension strength test data reported by Turvey and Wang (2003).

The open-hole (notched) tensile strength reduction factors in the longitudinal and transverse material directions are defined as the inverse of the corresponding effective stress concentration factors:

$$k_L^{-1} = \frac{F_L^m}{F_L^t} \leq 1 \quad (C7.5.1-3)$$

$$k_T^{-1} = \frac{F_T^m}{F_T^t} \leq 1 \quad (C7.5.1-4)$$

The numerical values of the open-hole strength reduction factors in Equations (7.5.2-2) and (7.5.3-2) were computed based on tensile strength data of pultruded plates with central circular holes (Lopez-Anido 2009), as shown in Figures C7.5.1-1 and C7.5.1-2.

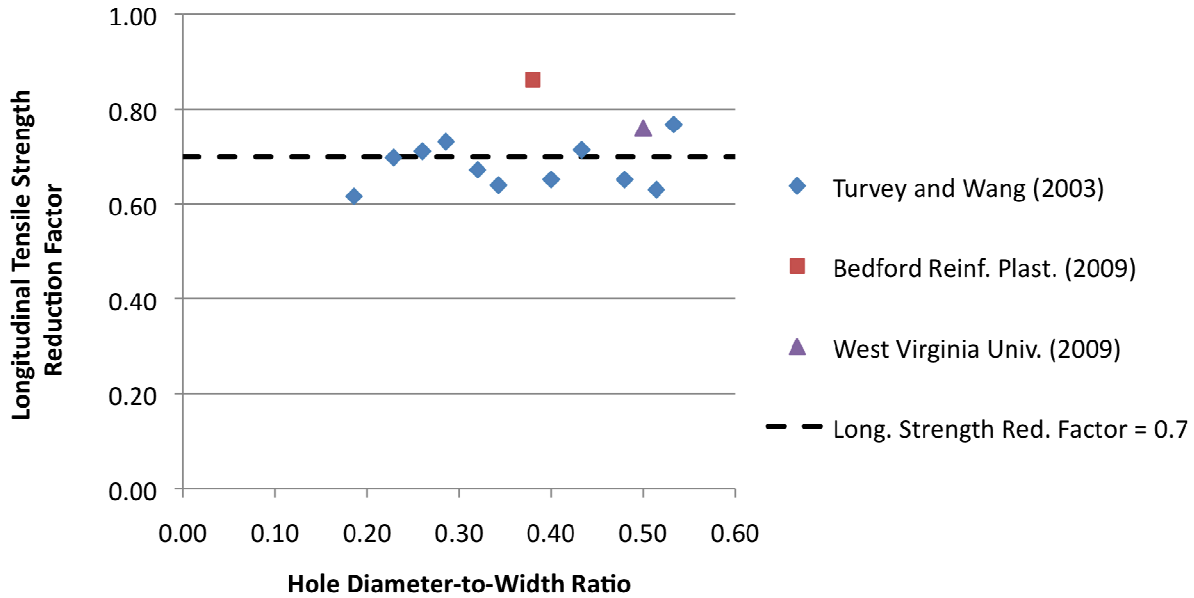

Figure C7.5.1-1 Open-Hole Tensile Strength Reduction Factor in the Longitudinal Direction (Lopez-Anido 2009)

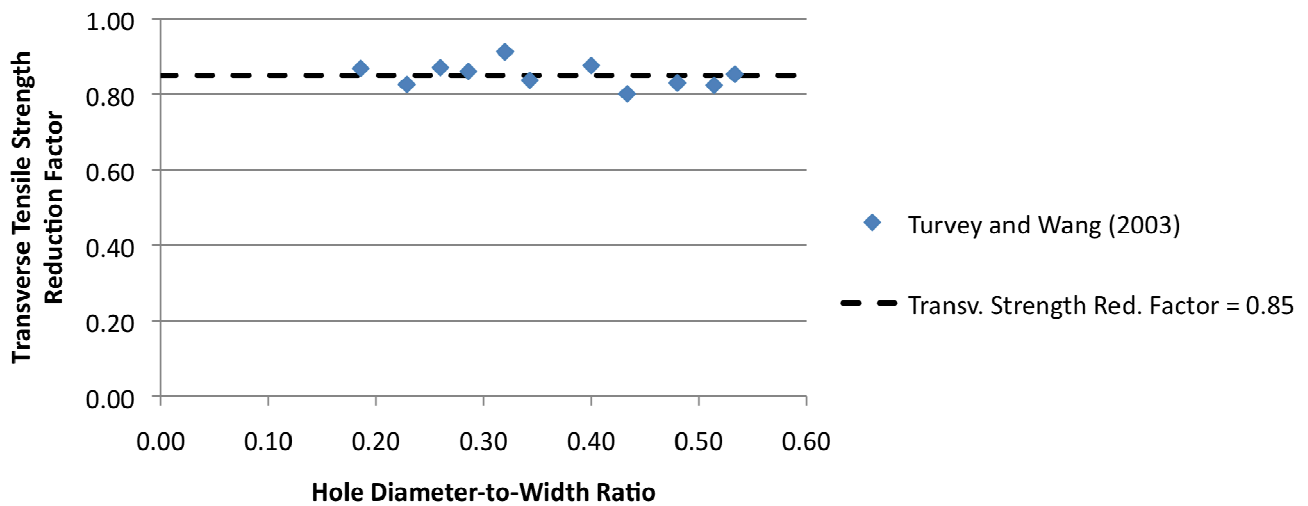

Figure C7.5.1-2 Open-Hole Tensile Strength Reduction Factor in the Transverse Direction (Lopez-Anido 2009)

The characteristic open-hole net-section tensile strengths of pultruded plates in the principal material directions, F_L^{tn} and F_T^{tn} , are obtained in accordance with ASTM D5766 test method.

C7.6 Design of Plates Subjected to In-Plane Compressive Loading

C7.6.1 Nominal Compressive Strength of Plates

The nominal strength of rectangular pultruded plates, which satisfy the provisions of Section 7.2, subjected to in-plane compressive loading is based on orthotropic plate buckling. Pultruded plates that satisfy the deviation limits specified in Section 7.6.1 do not require an analysis of geometric imperfections and eccentricities in the computation of the nominal buckling strength. This specification does not attempt to quantify the effect of plate post-buckling on the nominal strength.

C7.6.3 Nominal Strength of Plates Subjected to Longitudinal Compression

An explicit expression for the nominal buckling stress (CMH-17 2009, Barbero 1999, Kollar and Springer 2003) is provided in Equation (7.6.3-2) for three types of plate boundary conditions:

1. Rectangular plate simply supported around the edges ($k_{cr} = 1.0$)
2. Rectangular plate with fixed supports around the edges ($k_{cr} = 1.3$)
3. Rectangular plate with partially restrained rotation around the edges ($1.0 < k_{cr} < 1.3$)

Equation (7.6.3-2) with $k_{cr} = 1.0$, which is referred to as the “long-plate approximation”, is the most frequently used orthotropic plate buckling equation in design of composite material structures. This equation accurately predicts the buckling strength for long plates ($a/b > 4$). For shorter plates, Equation (7.6.3-2) provides a conservative estimate of the buckling strength. Comprehensive testing of composite material plates has shown Equation (7.6.3-2) to be valid except for very narrow plates ($b/t < 20$) (CMH-17 2009, Barbero 1999).

The elastic buckling stress for other plate boundary conditions can be obtained using engineering mechanics methods (Timoshenko and Woinowsky-Kreiger 1964, Whitney 1987, Kollar and Springer 2003). Exact analyses for orthotropic plates with partially restrained boundary conditions are provided by Bank and Yin (1996) and Qiao et al. (2001).

For example, the longitudinal elastic buckling stress of a rectangular plate with three edges simply supported and one unloaded edge free (parallel to the material longitudinal direction) is

$$F_L^{cr} = \left(\frac{t}{b} \right)^2 \frac{\pi^2}{6} \left(\frac{1}{2} \left(\frac{b}{a} \right)^2 E_L + \frac{6}{\pi^2} G_{LT} \right) \quad (C7.6.3-1)$$

where

- t = Thickness of the plate
- a = Span length of the plate in the material longitudinal direction
- b = Span length of the plate in the material transverse direction
- E_L = Characteristic longitudinal elastic modulus
- G_{LT} = Characteristic in-plane shear modulus

The following conservative approximation was introduced in the elastic buckling stress equations in Sections 7.6.3, 7.6.4, 7.7.3 and C7.6.3

$$1 - \nu_{LT} \nu_{TL} = 1 - \nu_{LT}^2 \frac{E_T}{E_L} \cong 1 \quad (\text{C7.6.3-2})$$

The longitudinal nominal buckling strength per unit length ($N_{L,n}^c$) is obtained by multiplying the elastic buckling stress by the plate thickness.

The elastic properties (elastic moduli) in the material longitudinal and transverse directions and the Poisson's ratio for the plate nominal buckling strength equations are considered flexural properties. However, for homogeneous pultruded plates with same elastic properties in tension and compression, the elastic moduli in the material longitudinal and transverse directions and the Poisson's ratio can be obtained from the tension test method (ASTM D638); the in-plane shear modulus can be obtained from the V-notched beam shear test method (ASTM D5379). Alternatively, the compression test method (ASTM D6641) can be used to obtain elastic properties in the material longitudinal and transverse directions and the Poisson's ratio.

A reference value for the in-plane longitudinal (major) Poisson's ratio, $\nu_{LT} = 0.32$, was reported for E-glass/vinyl ester pultruded plates (3/8 to 1 in thick) reinforced with rovings and continuous filament fiber mat (Bank 2005).

C7.6.4 Nominal Strength of Plates Subjected to Combined Longitudinal and Transverse Compression

An explicit expression for the elastic buckling stress is provided in Equation (7.6.4-2) for the case of a rectangular plate simply supported around the edges subjected to combined longitudinal and transverse compression (biaxial loading). Equation (7.6.4-2) assumes that the numbers of plate buckling half-waves in the material longitudinal and transverse directions are equal to one, which minimizes the elastic buckling stress for the range of applied transverse to longitudinal compressive loading between 0.3 and 1.0. For other ranges of applied transverse to longitudinal compressive loading, the elastic buckling stress can be obtained by minimizing a general explicit expression as a function of the number of plate buckling half-waves in each direction (CMH-17 2009).

If the rectangular plate rotation is partially restrained around the edges, then Equation (7.6.4-2) provides a conservative estimate of the nominal buckling strength (Kollar and Springer 2003).

C7.7 Design of Plates Subjected to In-Plane Shear Loading

C7.7.1 Nominal In-Plane Shear Strength of Plates

The nominal strength of rectangular pultruded plates, which satisfy the provisions of Section 7.2, subjected to in-plane shear loading is determined by the lower value between material rupture and orthotropic plate buckling.

C7.7.2 Nominal Material Rupture Strength of Plates Subjected to In-Plane Shear

The test method for in-plane shear (ASTM D5379) is also referred to as the "V-notched beam test" or "Iosipescu shear test" (See Figure C7.7.2-1). A testing procedure and a data reduction method to generate in-plane shear modulus and in-plane shear strength based on the V-notched beam test method (ASTM D5379) is presented in Bank (1990). The statistical distribution of in-plane shear modulus and strength of

pultruded coupons obtained by the V-notched beam test method was characterized by Sonti et al. (1995) and Sonti and Barbero (1996).

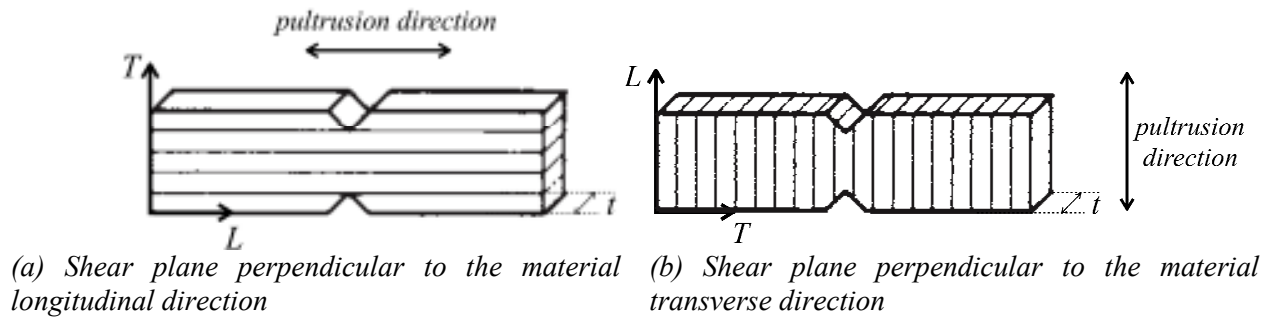

Figure C7.7.2-1 Pultruded Plate V-Notched Beam Specimens for In-Plane Shear Strength, F_{LT} , according to ASTM D5379

C7.7.3 Nominal Buckling Strength of Plates Subjected to In-Plane Shear

An explicit expression for the nominal buckling strength (Kollar and Springer 2003) is provided in Equation (7.7.3-2) for the case of a rectangular pultruded plate simply supported around the edges subjected to shear loading. This expression, which was derived for an infinitely long plate ($a \rightarrow \infty$), provides a conservative estimate of the buckling strength for plates with an aspect ratio $a \geq b$.

For plates with an aspect ratio $a < b$, Equation (7.7.3-2) is overly conservative. In this case, a better estimate of the buckling strength can be obtained by replacing the dimension b by the dimension a , and by interchanging E_L and E_T .

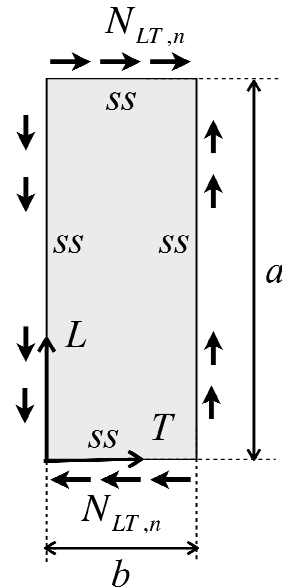

Figure C7.7.3-1 In-plane Shear Loading

C7.8 Design of Built-up Members

C7.8.1 Design Basis

Qualification by testing in accordance with Section 2.3.2 is deemed as an acceptable method to determine the nominal strength of built-up members and their components and connections.

The determination of strength and stiffness of built-up members by testing is based on achieving the same level of reliability and performance as achieved by analysis for gravity load design. It is assumed that the reference strength is the mean value of strength determined directly from structural testing.

Qualification by testing must be conducted at a testing laboratory approved by the Engineer of Record. A technical evaluation report presenting the findings of the qualification tests, as to the compliance with the requirements in this Standard, must be issued by the testing laboratory.

A comprehensive test method to assess the buckling and postbuckling response of thin-walled curved composite panels stiffened with T-stringers subjected to uniaxial compression was presented by Kling (2008). No specific qualification test method for built-up members has been given in this standard, because it may be found advisable to vary the procedure according to the loading and structural conditions, and the level of performance required.

C7.8.2 Design of Built-up Members Subjected to In-Plane Tensile Loading

The primary design concern is that the plate and components be well connected so that the axial strains in all components are equal or nearly equal and that the effects of any splices be properly accounted for in the member strength assessment.

The effective net area of plates in built-up members is determined in accordance with the requirements set forth in Section 2.10.3.

C7.8.3 Design of Built-up Members Subjected to In-Plane Compressive Loading

Unless the pultruded plate and components of a built-up compression member are rigidly attached, the interlayer slip between the components will reduce the assembly's stiffness because of the resulting incomplete composite action. Thus, the strength of a built-up compression member can vary between that of a rigidly connected column if the connector stiffness is very high to a smaller value equal to the sum of the individual component strengths acting independently.

Transformed section concepts must be used if the well-connected compression member includes pultruded plates and components of different material stiffnesses, since the critical buckling expressions assume a homogeneous member with one effective material stiffness. Analysis of partially connected compression members must consider both differences in material component stiffnesses and the connector stiffness characteristics.

C7.8.4 Design of Built-up Members Subjected to Through-the-Thickness Shear

Bolted connections of pultruded plates and components subjected to out-of-plane loadings are designed for pull-through strength in accordance with the provisions in Section 7.4.5.

C7.8.5 Design of Panel-Based Assemblies

Pre-engineered panel-based assemblies are made of rectangular plates connected with equidistant web components (stringers or ribs) parallel to one of the plate principal material directions. The performance of panel-based assemblies depends on the load-carrying capacity and the quality of the pultruded components, and the integrity of connections between components. Further, such assemblies must be subject to an ongoing quality control program. Designs of panel-based assemblies that include non-rectangular plates and/or non-parallel web components are outside the scope of this standard.

The structural behavior of panel-based assemblies can benefit from partial composite action along the parallel web components and load sharing action arising from the plate crossing the webs. The magnitude of these two effects depends on: a) the stiffness of the connectors attaching the plate to the webs, b) the relative stiffness of the webs to the plate, c) web spacing; d) plate joints, and e) loading pattern. Connector stiffness depends upon type, size and spacing of connectors.

When structural adhesives and mechanical fasteners are used in combination, the nominal strength of the plate to web component connection is determined based on the fasteners (bolts) alone. Illustrations on relevant forms of connections for panel-based assemblies are depicted in Figure C7.8.5-1.

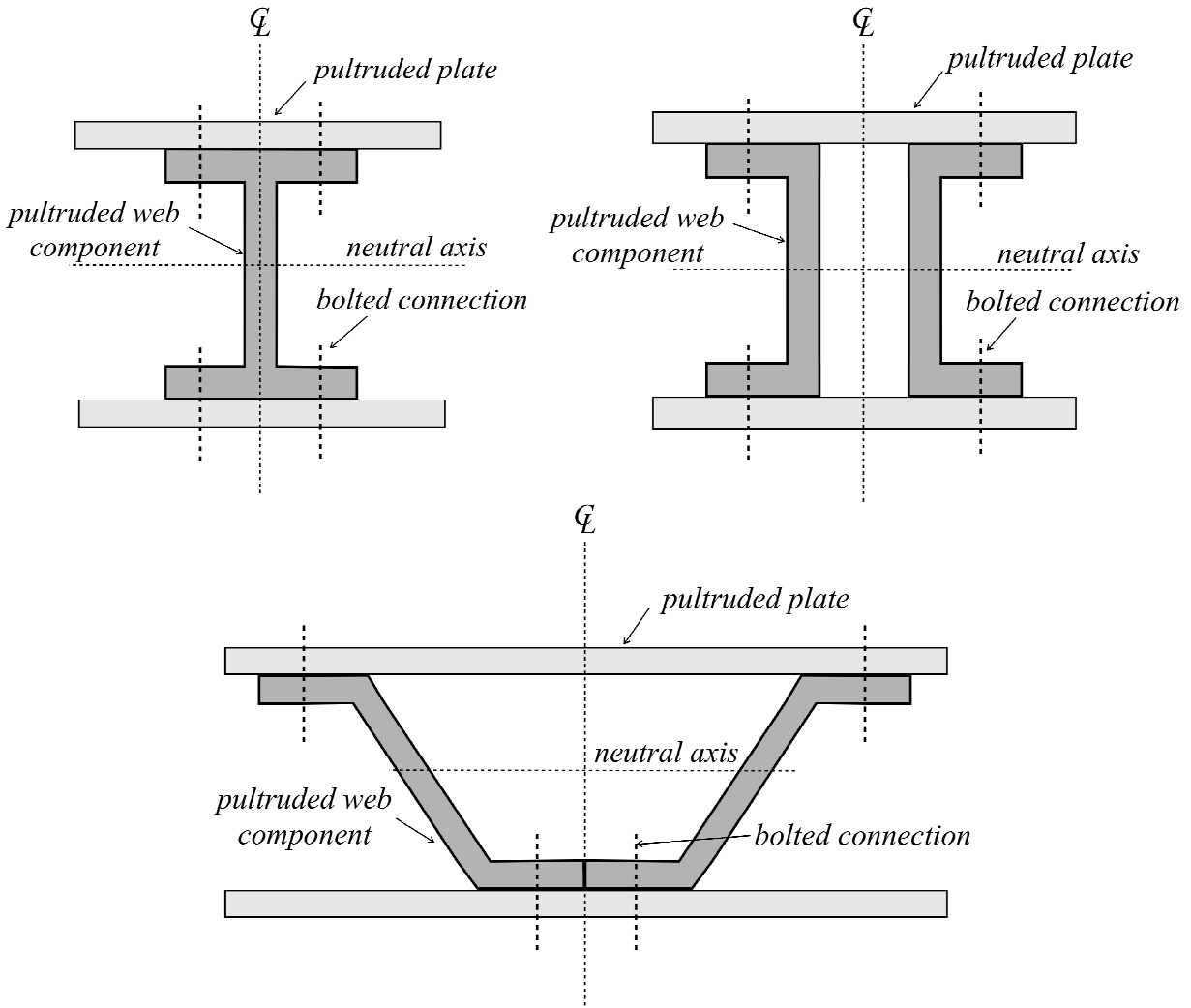

Figure C7.8.5-1 Schematics of Connections in Panel-Based Assemblies Cross-Sections

C7.8.5.1 Nominal Flexural Strength of Panel-Based Assemblies for One-Way Plate Bending

Panel-based assemblies can be fabricated with parallel web components attached to one face of the rectangular plate, resulting in an open-cross section. Alternatively, panel-based assemblies can be fabricated with top and bottom rectangular plates (flanges or skins) and parallel web components attached in between the plates, resulting in a closed-cross section. Illustrations of panel-based assemblies for one-way plate bending (typical for floors and roofs) are depicted in Figures C7.8.5.1-1 and C7.8.5.1-2.

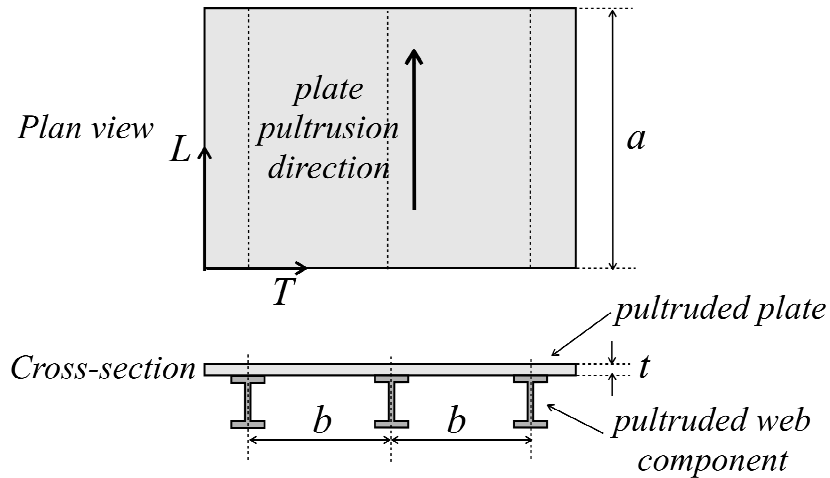

Figure C7.8.5.1-1 Panel-based Assembly with Webs Parallel to the Plate Material Longitudinal Direction Attached to One Face

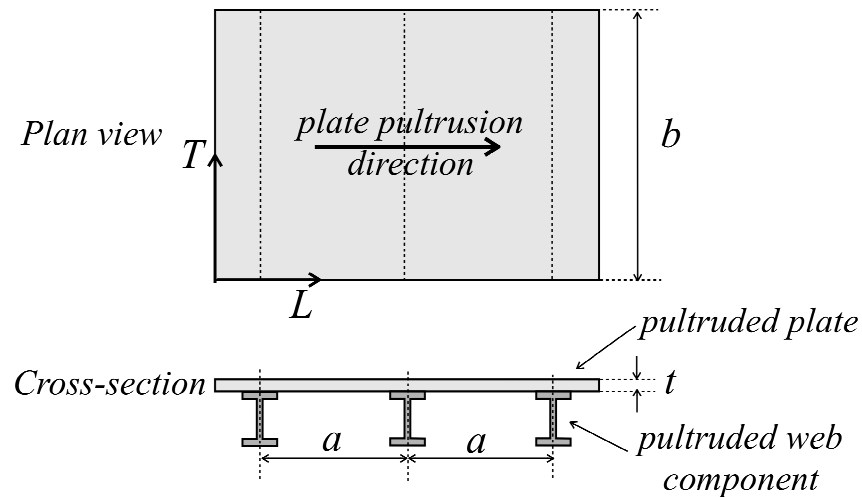

Figure C7.8.5.1-2 Panel-based Assembly with Webs Parallel to the Plate Material Transverse Direction Attached to One Face

C7.8.5.2 Nominal Flexural Strength of Panel-Based Assemblies for Two-Way Plate Bending

Panel-based assemblies for two-way plate bending can be fabricated with top and bottom rectangular plates (flanges or skins) and parallel web components attached in between the plates, resulting in a closed-cross section. Illustrations on relevant cross-sections of panel-based assemblies are depicted in Figure C7.8.5.2-1.

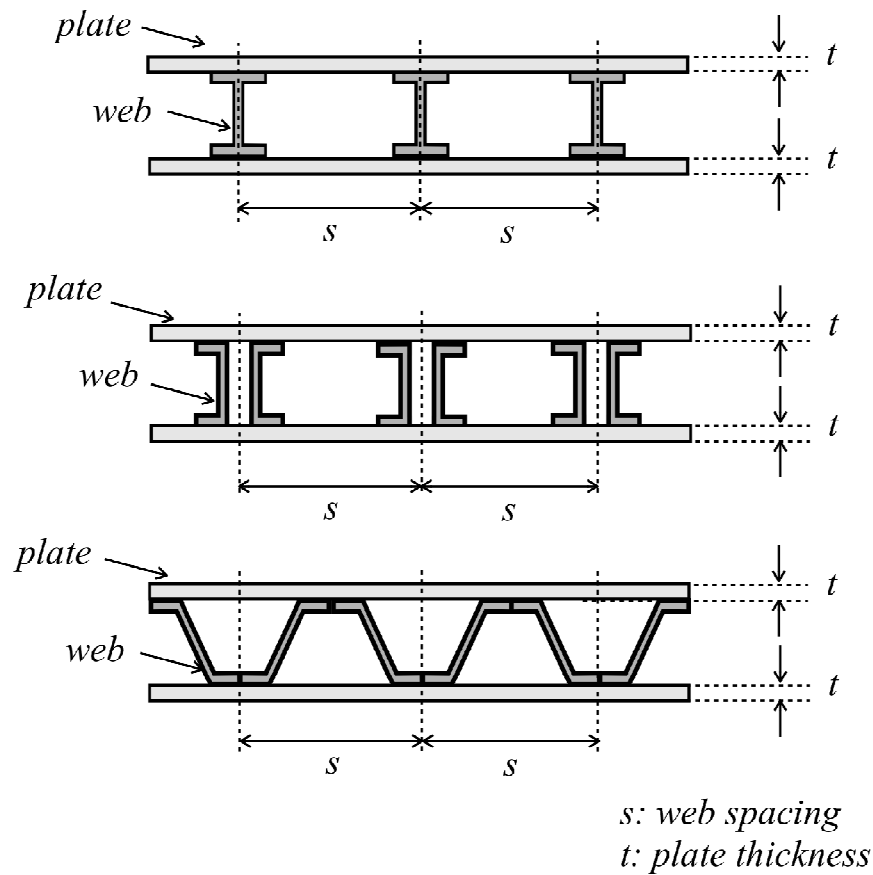

Figure C7.8.5.2-1 Schematics of Panel-based Assemblies with Plates and Parallel Webs Attached in Between the Plates

C7.8.6 Design of Plate Girders

The design procedure for plate girders consists of evaluating a series of checking equations representing potential failure modes and serviceability limit states for the particular assembly.

Plate girders are categorized by their components and cross-sectional geometries. An example of the structural evaluation of a built-up box beam system can be found in Evernden (2006). When structural adhesives and mechanical fasteners are used in combination, the nominal strength of the plate to stiffener connection is determined based on the fasteners (bolts) alone. Illustrations on relevant forms of connections for open-section and closed-section plate girders are depicted in Figure C7.8.6.

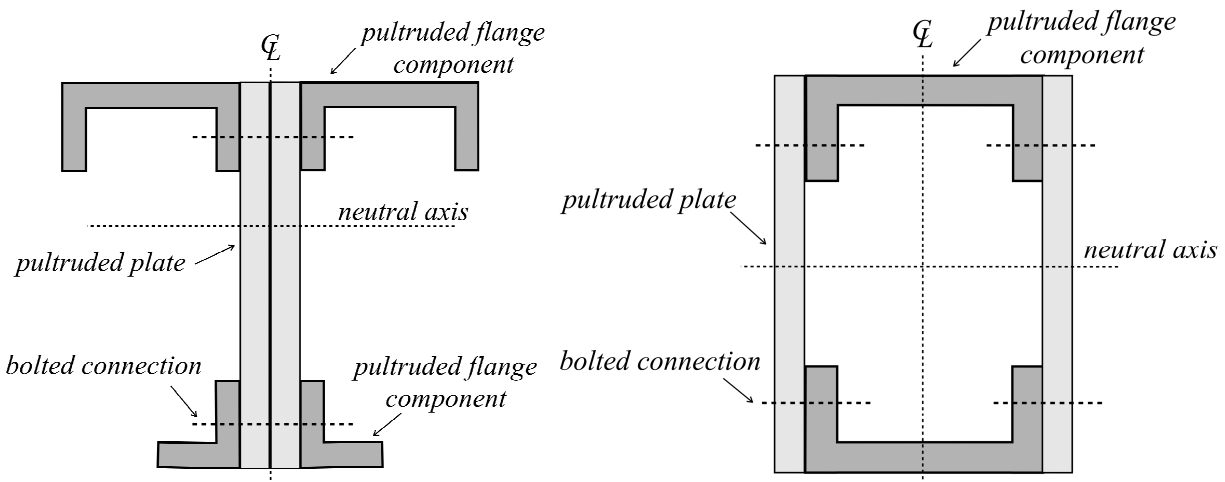

Figure C7.8.6 Schematics of Connections in Plate Girders

C7.8.7 Design of Shear Walls and Diaphragms

The term diaphragm refers to a roof, floor or other membrane acting to transfer lateral forces to the vertical resisting elements. The term shear wall refers to a wall designed to resist lateral forces parallel to the plane of the wall.

Design of a pultruded shear walls and diaphragms is a lateral force design process. In resisting and transferring lateral forces, shear walls and diaphragms act as thin, deep beams comprised of sheathing (pultruded plates) connected to structural framing (pultruded sections). The sheathing acts as a web material, and boundary members function as flanges or chords. It is assumed that chords resist axial forces and webs resist shear. Induced moment is resisted by the couple of chord forces, with any moment resistance provided by the webs being ignored. Shear stresses are assumed to be distributed uniformly through the depth of shear walls and diaphragms.

Considerations in the development of shear wall and diaphragm (in-plane shear) design capacities include:

- a) Material rupture of the plate in in-plane shear,
- b) Plate (web) buckling due to in-plane edge shear loads,
- c) Plate-to-framing components connection capacity: lines (rows) of fasteners at plate edges, fastener spacing, and material rupture due to pull-through of the fasteners, and
- d) Framing component section: axial capacity and tension failure.

The methods for evaluating the shear capacity of a typical section of a framed shear wall, supported on a rigid foundation and having load applied in the plane of the wall along the edge opposite the rigid support and in a direction parallel to it are described in the standard practice ASTM E564. When required in the design, the deflection of a shear wall or a diaphragm is calculated in accordance with principles of engineering mechanics or by other approved methods.

The performance of the shear wall is influenced by the type and spacing of framing fasteners, plate-to-frame connections and the wall assembly anchorage connection to the floor, or foundation. When structural adhesives and mechanical fasteners are used in combination, the nominal strength of the shear wall connections is determined based on the fasteners (bolts) alone.

Openings in diaphragms have the shear force on their two sides distributed in proportion to their size. All pultruded framing including boundary members provided at shear wall and diaphragm perimeters and openings are proportioned to resist the induced forces.

C7.9 Design of Decking Members

C7.9.1 Design Basis

Pultruded decking members are used in applications such as platforms, walkways, roofs, floors, wind walls, bridge decks, building panel systems, formwork and trench covers. Panels can be connected using connectors, toggles and/or hangers. Joints between panels and connectors can be bonded during assembly. Modular decking systems can be made of interlocking profiles (Dutta et al. 2007).

C7.10 Design of Plates for Serviceability

In addition to strength limit states, plates and built-up members must also satisfy serviceability limit states that define functional performance under load and include such items as deflection and vibration. Shear deformations can be neglected for computing deflections of pultruded plates that satisfy the requirements set forth in Section 7.2.

C7.11 References

1. ASTM D6416, "Standard Test Method for Two-Dimensional Flexural Properties of Simply Supported Sandwich Composite Plates Subjected to a Distributed Load," ASTM Int., West Conshohocken, PA, 2007.
2. ASTM D7264, "Standard Test Method for Flexural Properties of Polymer Matrix Composite Materials," ASTM Int., West Conshohocken, PA, 2007.
3. ASTM E564 "Standard Practice for Static Load Test for Shear Resistance of Framed Walls for Buildings," ASTM Int., West Conshohocken, PA, 2006.
4. Bank, L.C., "Shear Properties of Pultruded Glass FRP Materials," *Journal of Materials in Civil Engineering*, Vol. No. 2, pp. 118-122, 1990.
5. Bank, L.C and Yin, J. "Buckling of Orthotropic Plates with Free and Rotationally Restrained Unloaded edges," *Thin-Walled Structures*, Vol. 24, pp. 83-96, 1996.
6. Bank, L.C. "Chapter 16 - Fiber-Reinforced Polymer Composites," *Handbook of Structural Engineering*, 2nd Ed., Eds. W.F. Chen and E.M. Lui, CRC Press, 2005.
7. Barbero, E.J., "Introduction to Composite Materials Design," Taylor & Francis, 1999.
8. Berube, K.A., and Lopez-Anido R.A. "Variability in the Material Properties of Polymer Matrix Composites for Marine Structures," *Journal of ASTM International*, Vol. 7, No. 4, 18 pp., 2010.
9. Clarke, J.L. (Ed.), "Structural Design of Polymer Composites, Eurocomp Design, Code and Handbook," E&FN Spon, London, 1996.
10. CMH-17 Composite Materials Handbook, Vol. 3, Polymer Matrix Composites Materials Usage, Design, and Analysis, 2009.
11. Dutta, P.K., Lopez-Anido, R., and Kwon, S.K., "Fatigue Durability of FRP Composite Bridge Decks at Extreme Temperatures," *International Journal of Materials and Product Technology (IJMPT)*, Vol. 28, No. 1/2, pp. 198-216, 2007.
12. Evernden, M.C., "Structural Evaluation of a Novel Box Beam System of PFRP Shapes," Ph.D. Thesis, University of Warwick, UK, 2006.
13. Gere, J.M. and Timoshenko, S.P., *Mechanics of Materials*, 4th ed., PWS Pub. Co., Boston, MA, 1997.

14. Hart-Smith, L. J., "Bolted Joint Analyses for Composite Structures - Current Empirical Methods and Future Scientific Prospects," in *Joining and Repair of Composite Structures*, ASTM STP 1455, K.T. Kedward and H. Kim, Eds., ASTM International, pp. 127-160, West Conshohocken, PA, 2004.
15. Kling, A. "Stability Design of Stiffened Composite Panels – Simulation and Experimental Validation," in *Buckling and Postbuckling Structures – Experimental, Analytical and Numerical Studies*, Eds. B.G. Falzon and M.H. Aliabadi, Imperial College Press, London, UK, 2008.
16. Kollar, L.P. and Springer, G.S. "Mechanics of Composite Structures," Cambridge University Press, Cambridge, UK, 2003.
17. Lopez-Anido, R., "Open-Hole Tensile Strength for Pultruded Plates," Technical Report, University of Maine, Orono, ME, 2009.
18. Mottram, J.T., "Prediction of Net-Tension Strength for Multirow Bolted Connections of Pultruded Material Using the Hart-Smith Semi-empirical Modeling Approach," *Journal of Composites for Construction*, in-press, 2010.
19. Qiao, P., Davalos, J.F. and Wang, J., "Local Buckling of Composite FRP Shapes by Discrete Plate Analysis," *Journal of Structural Engineering*, Vol. 127, pp. 245-255, 2001.
20. Sonti, S., Barbero, E.J., and Winegardner, T., "Determination of Shear Properties for RP Pultruded Composites," *Journal of Reinforced of Plastics and Composites*, Vol. 14, pp. 390-401, 1995.
21. Sonti, S.S. and Barbero, E.J. "Material Characterization of Pultruded Laminates and Shapes", *Journal of Reinforced Plastics and Composites*, Vol. 15, No. 7, pp 701-717, 1996.
22. Thoppul, S.D., Finegan, J. and Gibson, R.F., "Mechanics of Mechanically Fastened Joints in Polymer–Matrix Composite Structures – A Review," *Composites Science and Technology*, Vol. 69, No. 3-4, pp. 301-329, 2009.
23. Timoshenko, S.P., and Woinowsky-Kreiger, S., "Theory of Plates and Shells," McGraw-Hill Classic, 1964.
24. Turvey, G. J. and Wang, P., "Open-hole Tension Strength of Pultruded GRP Plates," *Proceedings of the Institution of Civil Engineers: Structures and Buildings*, Vol. 156, No. 1, pp. 93-101, 2003.
25. Ugural, A.C., "Stresses in Plates and Shells," McGraw-Hill, New York, NY, 1981.
26. Whitney, J.M., "Structural Analysis of Laminated Anisotropic Plates," Technomic Publishing Co., Inc., Westport, CT, 1987.

C8. DESIGN OF BOLTED CONNECTIONS

C8.1 Scope

The provisions of Chapter 8 cover the design of bolted connections and the strength formulae in the chapter are not based on fatigue testing.

A bearing-type connection is one where the transfer of connection force is entirely by way of bearing between the shaft(s) of the bolting and the connecting components. For the design of bearing-type connections it is assumed that there is no force transferred through friction between the connected elements in the connection (AISC, 2005). In this chapter the term ‘components’ is used as a collective word for all types of members and connecting elements used to fabricate a FRP frame structure.

The types of bolted connections scoped by the chapter do correspond to the connection engineering drawings in the design manuals from the manufacturers of pultruded sections (Anon, 2010; 2010a; 2010b). It does not preclude other connection details that also transfer the connection force through bolt bearing. In this standard the meaning of the word connection is synonymous with the term joint. Connection elements refer to those parts in the connection detailing that are used to transfer forces between the members in the structure. Turvey (2000) and Bank (2006) provide information on applications of bolted connections in a number of pultruded frame structures.

The design of bolted connections with FRP materials is much more complex than when the connecting material is steel or another ductile metal. The principal reasons for this are the number of different failure modes and strengths, the changes in mechanical properties with orientation and environmental conditioning, and the linear elastic response to the onset of damage, which at 68 F (20°C) often coincides with ultimate (brittle) material failure. The lack of material yielding (i.e. a rapid increase in strain under constant or slowly increasing stress) reduces the ability of the FRP to alleviate stress concentrations by stress redistribution and reduces the degree of damage tolerance that increases the reliability in designing bolted connections. Increasing temperature will eventually cause resin softening and changes in connection response when the material is deformed (Turvey and Wang 2007; 2007a).

The FRP materials to be used for the connections covered by Chapter 8 are specified in Chapter 2. If FRP products other than those manufactured by pultrusion are used the designer is required to establish the appropriate characteristic strength properties for the material, as specified in Chapter 2.

To simplify the design process gusset, splice plates and angles connecting elements are to be of a ductile metal and their design is to be in accordance with the relevant American standard for that material. It may be appropriate to replace metal elements with FRP material elements after pre-qualification testing has been used to verify that the connection design is to be fit for purpose over the service life of the structure. The chapter provides the provisions necessary for initial sizing of FRP connection elements.

Chapter 8 does not cover design of connections with mechanical fasteners such as Unistrut connectors, nails, staples, screws or other proprietary fastening systems. Types of bolts to be used are to be for bearing-type connections, as FRP materials are not suitable for pretensioned or slip-critical connections. Structural bolt with ASTM A490 steels cannot be used. The shank of the bolt should be smooth over the

full length that is bearing into the FRP material; for assembly the thread length should not exceed one third of the thickness of a plate.

This chapter does not provide guidance for the design of bolted connections using FRP bolts. Proprietary FRP bolts (Erki, 1995) may be used following guidance from the manufacturers and with the nominal connection strength based on testing that represents the actual connection detailing and loading.

Adhesive bonding using a proprietary structural epoxy may be used with a suitable type of mechanical fastener to connect non-load bearing stiffeners and doubler plates to the members. It is important for a satisfactory bond quality to follow the fabrication guidance of the adhesive supplier and of the Pultrusion Industry Council, given in Section 4.4.2 to the Code of Standard Practice for Fabrication and Installation of Pultruded FRP Structures (2011).

When structural adhesive and mechanical fastening are used in combination the differences in stiffness properties must be accounted for in the determination of the connection design resistance by rational engineering analysis. The resistance and sizing of connections using FRP components should be completed on the basis that the bolting will be sufficient to transmit the design actions.

Connections are to be designed on the basis of a realistic assumption of the distribution of internal forces and moments. The following assumptions should be used to determine the distribution of forces:

- a. the internal forces and moments assumed in the analysis are in equilibrium with the forces and moments applied to the connections
- b. each component in the connection is capable of resisting the internal forces and moments
- c. the deformations implied by this distribution do not exceed the deformation capacity of the bolts and the connected parts
- d. the assumed distribution of internal forces and moments should be realistic with regard to relative stiffnesses within the connection
- e. when a moment is applied to a connection, the distribution of the internal forces is to be linear (i.e. proportional to the distance from the center of rotation).

In general, bolted connections that are designed in accordance with the provisions of this standard will have a higher reliability than will the members they connect. This occurs primarily because the resistance factors (ϕ_b and ϕ_c) used in limit states for the design of bolted connections have been chosen to provide a higher reliability than those used for member design. Additionally, the controlling limit state in the structural member, for deflection or elastic buckling, is usually reached well before the strength limit state in the connection, such as bearing or net tension strength.

C8.1.1 Axially Loaded Connection Types

C8.1.1.2 Angles and Channels

For angle and channel members reference is given to the design of bolted connections to be found in this chapter. It may be appropriate to verify the design of the connection by testing.

C8.1.2 Placement of Bolts

Slight eccentricities, say up to 10 per cent of the controlling dimensions, between the gravity axis of single and double angle members and the center of gravity of connecting bolts may be ignored as having negligible effect on the static strength of such members.

C8.1.3 Framing Connections

A simple shear connection (Anon, 2010a; 2010b) transmits a moment that is negligible, across the connection components, compared to the moment of rupture of the beam (Mottram and Zheng, 1999). In the analysis of the structure, simple shear connections may be assumed to allow unrestrained relative rotation between the framing members and elements used to form the connection. A simple shear connection (with shear-plate or clip angle connecting elements (Anon, 2010b)) of pultruded FRP material should have sufficient rotation capacity to accommodate the required rotation determined by the analysis of the structure.

A moment connection transmits significantly higher moment across the connection. Although there have been full-sized tests to characterize possible moment connections for pultruded frame structures (Mottram and Zheng, 1999a; Turvey and Cooper, 2004), there is insufficient knowledge and understanding to require moment resistant connections to be excluded from the chapter. In this standard a connection with top and/or bottom seat elements is considered to be a moment connection. The only way to achieve a simple connection is to use clips bolted to the web of the member.

Section 2.9 covers the design requirements for connections and Chapter 8 covers the proportioning of the individual components of a bolted connection (angle, bolts, etc.) once the load effects on the connection are known. To satisfy Section 2.9 the design strength of structural connections shall not be at least less than 1 kip (4.5 kN). Should a column lose its continuity, below the locations where beams are connected, and the FRP clip angles are required to take tension action, to prevent disproportionate collapse, the results of component testing, by Turvey and Wang (2009), show that leg-angles of pultruded FRP material are likely to possess the required design strength.

This section establishes that the modeling assumptions associated with the structural analysis must be consistent with the conditions in Chapter 8 to proportion the connecting components.

For simple shear connections it is not necessary to include the connection elements as part of the analysis. They may often be idealized as pinned, positioned at intersections of the members, for the purpose of structural analysis (AISC, 2005). Once the analysis has been completed the deformations or forces computed may be used to proportion the connection components.

For simple shear connections the connection proportions are established after the final analysis of the structural design is completed, thereby greatly simplifying the design cycle.

Classification of a connection need not be dependent on the construction material and so a scheme for steel connections is acceptable (AISC, 2005). The secant stiffness K_s , at service loads, is taken as an index property of connection stiffness. Specifically, $K_s = M_s/\theta_s$, where M_s and θ_s , are moment and rotation, respectively, at service loads. If $K_s L/EI \leq 2$, with term L/EI for the beam member, then it is acceptable to consider the connection to be simple (in other words, the connection components can rotate without developing significant moment at the connection).

The strength of the connection is the maximum moment that it is capable of carrying and can be

determined from a physical test (Clarke, 1996; Zheng and Mottram, 1999; Turvey and Cooper, 2004). Connections that transmit < 20% of the minimum moment for the strengths of the section to rupture in tension or compression at a rotation of 0.02 radians are deemed to be simple. The frame connections designed to the provisions in this chapter will satisfy this requirement.

It is the responsibility of the designer to ensure that, under prying action, FRP clip angles in simple shear connections (Anon, 2010; 2010a; 2010b) do not have delamination damage at the instep of the leg-angle when the structure is subjected to service loads. A formula for design against this mode of failure cannot be given, because it cannot be analyzed, for the reasons given in C8.3.4.1, and because there is no experimental data. Current knowledge and understanding (Clarke, 1996; Mottram and Zheng, 1999; Turvey and Cooper, 2004) indicates that by choosing the recommended Chapter 8 geometry for clip angles of FRP material, the connection rotation for the onset of damage, at the instep, is likely to be 0.01 radians or higher. For web-clipped bolted connections the rotation at damage moment is higher than 0.013 radians for major-axis configurations and can be less than 0.01 radians for some minor-axis configurations (Zheng and Mottram, 1999; Turvey and Cooper, 2004). It is because there is limited knowledge and understanding for the moment-rotation properties and durability performance of every conceivable connection design using FRP elements that the standard requires pre-qualification by testing in accordance with Section 2.3.2.

The available rotation capacity of FRP connections as designed by this standard is unlikely to be adequate for the requirements of seismic design. Seismic resistance to the FRP frame can be provided using a substantially stiff lateral load resisting scheme composed of a structural system other than of FRP material.

C8.2 General Provisions

C8.2.1 Scope

This section defines the scope to the requirements that are to be used to design bolted connections with FRP components.

C8.2.1.2 Braced System and Column Spliced Connections

It may be appropriate to verify the design of the connection by testing because the strength formulae in Chapter 8 are only for plate-to-plate connections with single direction loading and also do not necessarily account for the overall connection performance.

C8.2.2 Bolts

If corrosion protection is required the bolts can be of stainless steel, according to the grades specified in ASTM F593. For other applications the coarse thread bolts can be of grade ASTM A307 or A325. For bolting together FRP to FRP components high strength ASTM A325 bolts cannot be properly tensioned to their design strength without special joint component design.

Bolts to be used in bearing-type FRP connections need only be tightened to the snug-tightened condition. Torque values for threaded bolts will vary depending upon the type of and diameter of steel bolt. Torque must be limited to eliminate the potential for “crushing” of the FRP material (Clarke, 1996) when bolts of ½ in. (12.7 mm) diameter or larger are used with oversized flat washers. Washers are expected to make full bearing contact with the FRP surfaces. Lubricants may significantly affect torque limits.

The snug-tightened condition is to be satisfied if the bolt tension induced by the bolt torque does not generate an average tensile stress in the steel in excess of 15 percent of the nominal tensile strength, as specified in Table 8.2. For bolted connections in structural steel (AISC, 2005) the tightening of the nut up to a snug-tightened condition requires an impact wrench. This latter condition is defined as the tightness attained by either a few impacts of an impact wrench or the full effort of a worker with an ordinary spud to bring the plies into firm contact. Snug-tightening the bolts in steel construction may induce relatively low clamping forces in the bolts (which would be higher for the same tightening because FRP material is much less stiff (say 1/10th) than steel). In general, at the snug-tight condition the bolt clamping forces can vary considerably because elongations are still within the elastic range. The magnitude of the clamping force that exists in a snug-tightened steel connection (joint) is not a consideration. It is however important with FRP materials, for the reasons given next. Clamping pressure will increase the bearing strength of the material. Cooper and Turvey (1995) showed that an increase of 50% over the pin-bearing strength (Mottram, 2009) is obtained using single bolted connections. It is important not to over-tighten bolting with FRP material to prevent through-thickness crushing (Clarke, 1996). Because of the viscoelastic response of the polymer matrix there is to be bolt force relaxation with time, and this will reduce the bearing strength. Bolt tension relaxation testing by Mottram (2005) has tentatively shown that the loss in pre-tension could be greater than 40 percent in 10 years.

Some basic considerations when assembling bolted connections of FRP materials are:

- Bolts should be cleaned of any burrs or other foreign debris
- Oversized flat washers better distribute the stresses from bolt tightening in the bolting region
- Verify proper alignment of the connection prior to inserting and tightening of the bolts
- Anti-seize lubricants will help the tendency for metallic bolts to gall
- Tightening of bolts should be undertaken at a uniform rate and use a cross bolt pattern of tightening
- Care should be taken to verify that the faying surfaces of the connection are being brought into firm contact while the bolts are not over tightened
- Lock washers, nylon locking nuts, or thread locker adhesives may be incorporated to prevent loosening of bolts and to insure the connection remain secure over its service life.

To prevent the nut from becoming loose due to creep relaxation a thread-locking sealant, locking nut or *jamb nut* may be used. The practice in steel design of deforming the steel bolt thread is not advisable. Because they will become ineffective with time high strength slip critical bolts, such as to grade ASTM A490, are not permitted in this standard.

C8.2.3 Size and Use of Bolt Holes

Holes for bolting may be drilled or reamed, preferably using diamond tipped bits. Holes cannot be punched like steel parts. Sealing holes (and other openings) with a resin coating is unlikely to change structural performance (Anon, 2011), the water absorption rate, or the ability of the FRP material to resistant environmental degradation in most cases. It is for this reason that sealing is not recommended in the chapter.

Because of the ineffectiveness of slip-critical bolting to transfer the connection force by friction

(Mottram, 2005), Chapter 8 does not permit, parallel to the connection force direction, oversized, short-slotted and long-slotted holes, when a connection component is of FRP material. Because pultruded members are compliant by way of their relatively low moduli of elasticity it is not deemed necessary to permit the use of enlarged holes for some latitude for adjustment in plumbing of the frame during erection.

In accordance with Code of Standard Practice for Fabrication and Installation of Pultruded FRP Structures (2011) fabrication tolerances shall not exceed the following:

Cut length: $\pm 1/8$ in. (3.2 mm)

Squareness of cuts: $\pm 1^\circ$

Hole locations: $\pm 1/16$ in. (1.6 mm)

Hole diameter to $1/2$ in.: $\pm 1/64$ in. (0.4 mm)

Hole diameter from $1/2$ in. to 1 in.: $\pm 1/32$ in. (0.8 mm).

C8.2.4 Nuts and Washers

The nuts to be used with the bolts of steel grades of C8.2.2 are to be of structural steel to ASTM A563 for bolts to A307 or A325, and of stainless steel to F594 for stainless steel bolts to F593. Washers to ASTM F844 are suitable for bolts of steel grades to ASTM A307 and A325. Stainless steel washers are to meet geometric requirements of ASTM F436, Table 2, and be of cold-worked stainless steel of the same type of stainless steel as the specified bolts and nuts.

To prevent crushing beneath the bolt head or nut a washer, of diameter at least twice the bolt diameter, is always required when a connecting component is of FRP. The minimum thickness of the washer is recommended to be $5/32$ in. (4.0 mm). This is not a requirement with steel for bolting torqued to the snug-tight condition (AISC, 2005) and represents one of differences in behavior that has to be accounted for in design.

C8.2.5 Connection Geometry Requirements

The connection geometries shown in Figures C8.1 and C8.2 have the connection force acting in the plane of the connection and perpendicular to the rows of bolts. A row of bolts is defined as two or more bolts across the width of the connection component (here represented by a plate of constant thickness with the connection force acting perpendicular to the width direction). Figure C8.1 defines the geometry for a multi-row connection with the bolting staggered. End distance, e_1 , is the minimum distance from the centerline of the row of bolt holes nearest to the unloaded edge that has a plane parallel to the centerline of the bolt row. Side distance, e_2 , is the minimum of the distances from the center of the bolts to their nearest unloaded edge (a side edge) that has a plane perpendicular to the centerline of the bolt row(s).

In Figure C8.2 the loaded and unloaded edges are defined with respect to the resultant direction of the connection force. When a connection component is loaded perpendicular to the direction of pultrusion or FRP material, the loaded edge is the edge in the direction towards which the bolt bearing force is acting. The unloaded edge(s) will be defined as the edge(s) that intercept the loaded edge.

One important feature to the design of bolted connections having with FRP components is that there are number of competing failure modes. In Figure C8.3 parts (a) to (f) show observed distinct modes for single bolted connections (Rosner and Rizkalla, 1995; Cooper and Turvey, 1995; Turvey, 1998) and parts

(g) and (h) show different distinct modes for connections having multi-rows of bolts (Prabhakaran *et al.*, 1996; Hassan *et al.*, 1997; Wang, 2004). Figure C8.3 does not show all observed modes (Mottram and Turvey, 2003). It should be recognized that the failure modes recorded, as shown in Figure C8.3, are from specimens in double-lap shear, with concentric tension load (for shearing force transfer across the bolts in bearing) and having the same side distance (e_2) to the unloaded edges that are perpendicular to the loaded edge. Fewer of the tests reported (Mottram and Turvey, 2003) have the angle θ in Figures C8.1 or C8.2 not set at either 0 or 90 degrees to the direction of pultrusion.

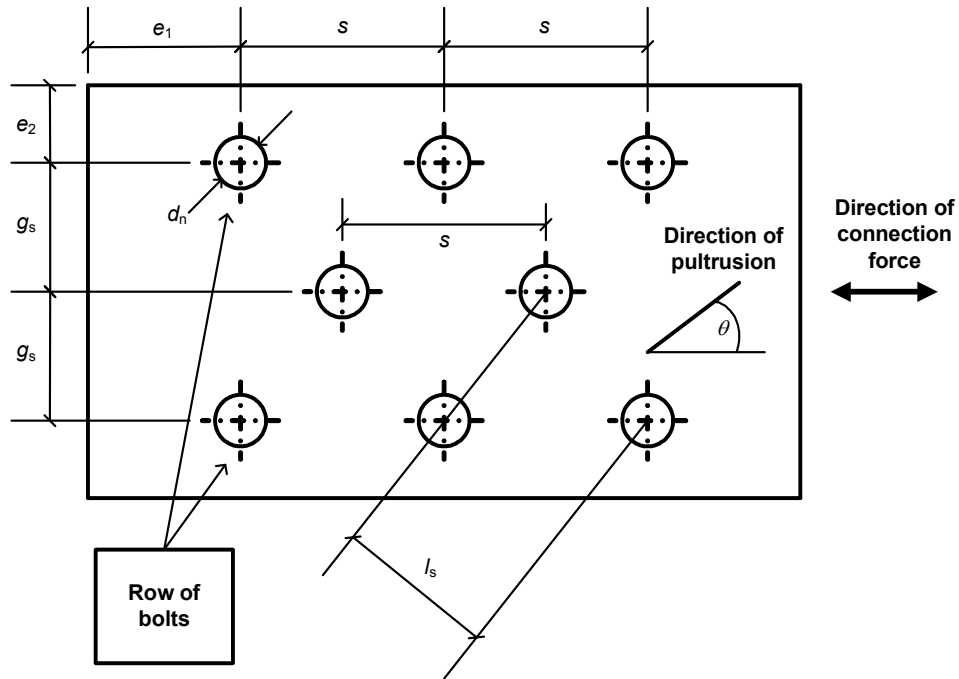

Figure C8.1. Notation and definitions for the connection geometry.

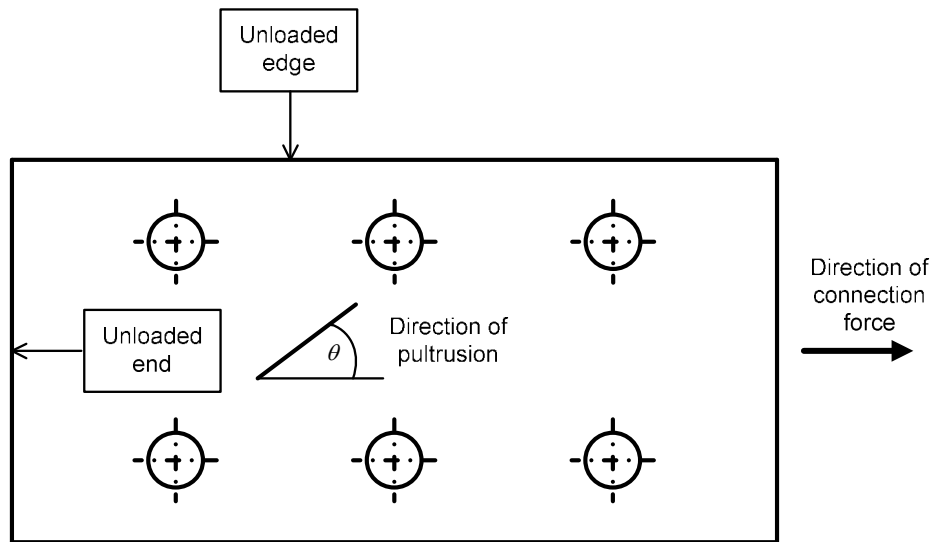

Figure C8.2. Definition for unloaded edge and unloaded end.

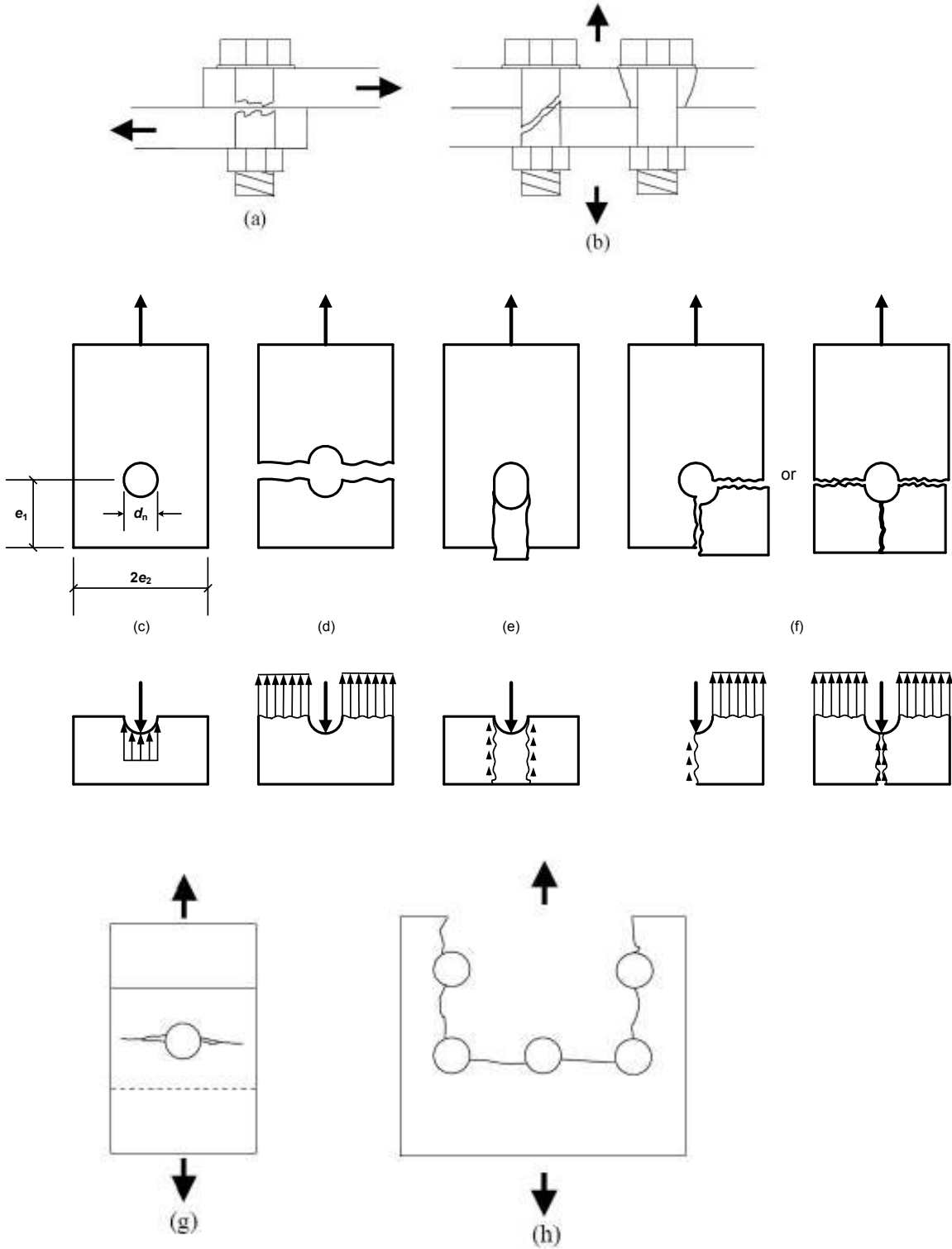

Figure C8.3. Bolted connection distinct modes of failure and simplified stress distributions (a) bolt failure, (b) through-the-thickness tension, (c) bearing, (d) net tension, (e) shear-out, (f) cleavage, (g) net tension 'splitting', when unloaded edges are not nearby, and (h) block shear.

The purpose of specifying the minimum connection dimensions in Table 8.1 is to have the strongest bolted connection whose mode of failure could be bearing, which is the only mode that might provide a degree of damage tolerance (Mottram and Turvey, 2003). The minimum requirements in Table 8.1 are for as-received pultruded material at 20°C (68°F). Note that for sections having a perpendicular element (e.g. box and channel shapes) along both the unloaded edges the side distance e_2 can be $< 1.5d$. For the calculation of strength the side distance is assumed to be $2e_{2,\min}$.

The spacings listed in Table 8.1 cannot guarantee that a bearing failure will always control when there is a single row of bolts (Rosner and Rizkalla, 1995; Turvey, 1998). From a series of physical tests by Turvey and Wang (2007, 2007a), following the material being subjected to (hot) water aging and/or elevated temperature it is known that failure of bolted connections can change from shear-out, cleavage or net tension to the bearing mode. This is associated with a more rapid reduction with environmental aging of the bearing strength than the material strengths that control net tension, shear-out or cleavage failure. When the orientation of the pultrusion is at 90 degrees to the load the dominant mode of failure is net tension. This occurs because with increase in orientation there is a significantly higher reduction in the tension strength than there is in the shear and bearing strengths that govern the other single-bolted modes. Chapter 8 does not specify any limits on maximum distances permitted for the connection geometry.

The other failure modes illustrated in Figure C8.3 are not desirable (Clarke, 1996), if unavoidable, because their failure mechanisms are sudden and can be catastrophic. Under most geometrical arrangements it is found that bolted connections with two and three rows of bolts will have the more sudden failure modes of either net tension (Hassan *et al.*, 1997) or a form of block shear (Prabhakaran *et al.*, 1996).

All minimum distances in Table 8.1 are to be met in order to design the connection, except for pitch spacing, s . It is recommended to meet these minimum distances whenever possible to avoid the strength reduction specified by the geometry factor, C_Δ , in Section 8.3.1.1.

C8.3 Connection Design

C8.3.1 Scope

Knowledge and understanding required for the design of bolted connections with pultruded sections and loading in the plane of the connecting elements is available from the results of series of physical tests, each conducted to study one of more of the variables that need to be accounted for. The test configuration is for a double-lap shear connection, and except, for the series of test by Erki (2005), at least one (often two) of the three flat plate components for the bolted connection is of structural steel. To characterize connections having a single, centrally placed, bolt there are the test results reported by Rosner and Rizkalla (1995), Cooper and Turvey (1995), Erki (1995), Turvey and Cooper (1995), Yuan *et al.* (1996), Steffen (1998), Turvey (1998), Yuan and Liu (2000), Y. J. Wang (2002), and P. Wang (2004). Similar test results for multi-bolted connection strengths and failure modes with two to nine bolts, and with up to three bolt rows are presented by Prabhakaran *et al.* (1996), Hassan *et al.* (1997), Prabhakaran and Robertson (1998) and P. Wang (2004) and Lutz (2005).

Mottram and Turvey (2003) review design practices and the main findings from the independent series of connection tests. They explain that the test data covers a wide range of bolted connection variables, with varying degrees of completeness. They made the observation that one reason for the large number and range of variables is the lack of a single coherent and recognized specification for the design and

fabrication of bolted connections for pultruded structures.

To account for a reduction a likely reduction in strength over time Equation 8.3.1-1 includes three factors. The moisture condition factor (C_M) and a temperature condition factor (C_T) are defined in Section 2.4.4 for Adjustments to Reference Strength.

8.3.1.1 Geometry Factor

The third of the three reduction factors is the geometry factor, C_A . It accounts for the occasions when the minimum pitch distance (s) in Table 8.1 cannot be met. This situation may arise when one of the connecting members or elements is not big enough to meet all minimum geometrical requirements. The general provision is in accordance with guidance to be found in the Standard for Load and Resistance Factor Design (LRFD) for Engineered Wood Construction (ASCE, 1995).

C8.3.2 Nominal strength of single row bolted connections

The bolt in a single-bolted connection or at a critical location in the connecting member must be checked for the six failure modes specified in Section 8.3.2 and shown by the illustrations in Figures C8.3(a) to C8.3(f). The minimum strength will control the design of the connection. NASA and American aircraft companies employ many of the design equations found in this chapter to design their aerospace composite structures (Chamis, 1980; Hart-Smith, 1987).

When comparing the available strength of the bolt or the critical section of the connecting FRP material, the nominal strength must be calculated based on the actual force distribution in the connection. The set of assumptions used in Chapter 8 for determining the forces and moments for the design of bolted connections are given in Section C8.1. Many of the design formulae in Chapter 8 are semi-empirical and are derived from experimental test results that loaded the bolted connection specimens in double-lap shear. The exception is for the formulae in Sections 8.3.2.1 and 8.3.2.2 which account for a connection force component acting in the direction perpendicular to the plane of the connection.

When the connection arrangement is single-lap shear the load path creates secondary actions, and their presence is known to lead to a reduction in connection strength. Because aerospace FRP laminates are generally not as thick as the components in pultruded structures, a reduction of 20% for the single-lap situation (Hart-Smith, 1987) is likely to be too low. For steel structures, Eurocode 3 Part 1-8 (BS EN 1993-1-8:2005) gives the maximum permitted reduction in bearing strength to be 40%. Typical strength losses of 20%, and higher, are expected because the rotation of the bolt under single shear causes a stress concentration near the interface of the components connected together. With the single-lap geometry failure might not be one of the distinct FRP modes shown in Figures C8.3(a) to C8.3(f). This is because of the stresses induced by a combination of axial and flexural deformations. The amount of strength loss in steel connections is a function of the bolt diameter-to-thickness ratio as well as the degree of moment restraint afforded by the tightening and the sizes of bolt head and nut. Until applicable research is available, it is assumed in Chapter 8 that a 40% reduction to the double-lap shear strength will be acceptable for the design of single-lap bolted connections with pultruded (and other FRP) material.

Figure C8.4 illustrates two situations where the resultant connection force is acting in directions that need not have the free end at a distance in excess of the minimum requirement given in Table 8.1. Under this condition there is additional resistance to the shear-out and cleavage modes of failure because of the presence at this free end of a FRP (plate) element that is perpendicular to the direction of the connection force. This means there is no requirement to check if their strengths are to govern the connection design.

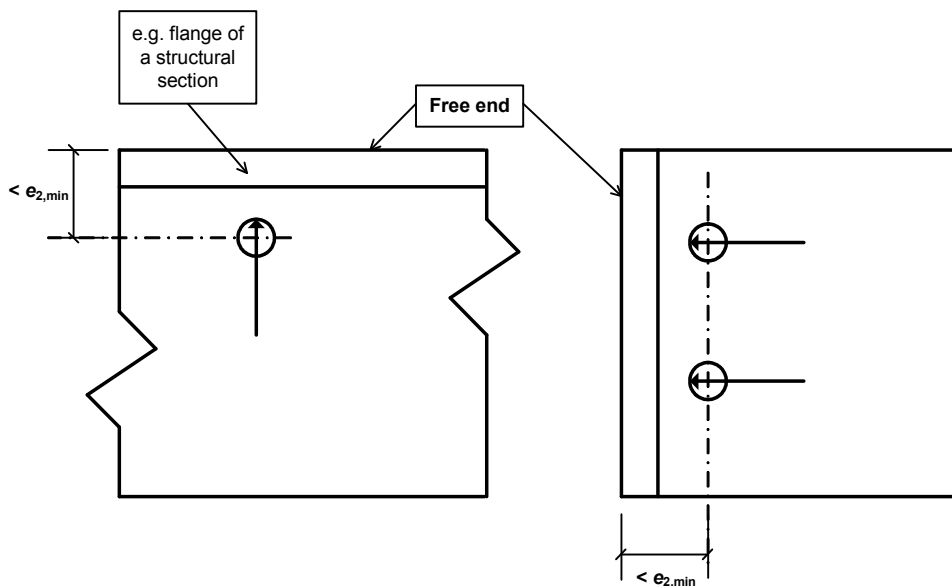

Figure C8.4 Connection force cases when the connection resistances of R_{sh} and R_{cl} need not be determined.

Plotted in Figure C8.5 are the ratios of the experimental strengths to those predicted using the equations in Section 8.3.2 for the distinct modes of net tension, bearing and cleavage. The bias factor is set to 1.0. The test strength results and the longitudinal tensile and in-plane shear strengths for the plotted values in the figure are sourced from two papers by Rosner and Rizkalla (1995, 1995a). For this exercise it is assumed that the longitudinal pin-bearing strength used in Equation 8.3.2-4 is 31.5 ksi (220 MPa). This strength is probably not pin-bearing because bearing failure occurred when there was a degree of lateral restraint from bolting tightening to 24 ft-lbs. (32.5 N.m). The connection details in this series of tests are similar to those permitted by Chapter 8. The pultruded material is $\frac{1}{2}$ in. (12.7 mm) flat sheet, the tightened steel bolt has a diameter of $\frac{3}{4}$ in. (19 mm), there is a nominal $\frac{1}{16}$ th in. (1.6 mm) clearance hole and the tensile load in the double-lap shear tests is aligned with the direction of pultrusion.

The strength tests were carried out under normal ambient laboratory conditions. Each test result in Figure C8.5 is from a single specimen (no specimen repetition) having different connection geometry, given by changing a dimension of end distance (e_1) and/or edge distance (e_2). Only one prediction for the 22 connections, labeled A1 to A22 (Rosner and Rizkalla, 1995a), in Figure C8.5 gave the lowest connection strength for an incorrect failure mode, and this was cleavage when the mode is bearing. However, the cleavage strength prediction is not significantly lower, and as found by Rosner and Rizkalla (1995a) from their series of tests there is a gradual transition from bearing to cleavage (or shear-out), as the ratio e_1/d falls below the minimum requirement in Table 8.1. For the test conditions chosen by Rosner and Rizkalla (1995), the shear-out failure mode did not control connection strength for the double-lap shear configuration, even when the end distance ratio e_1/d was < 1.0 .

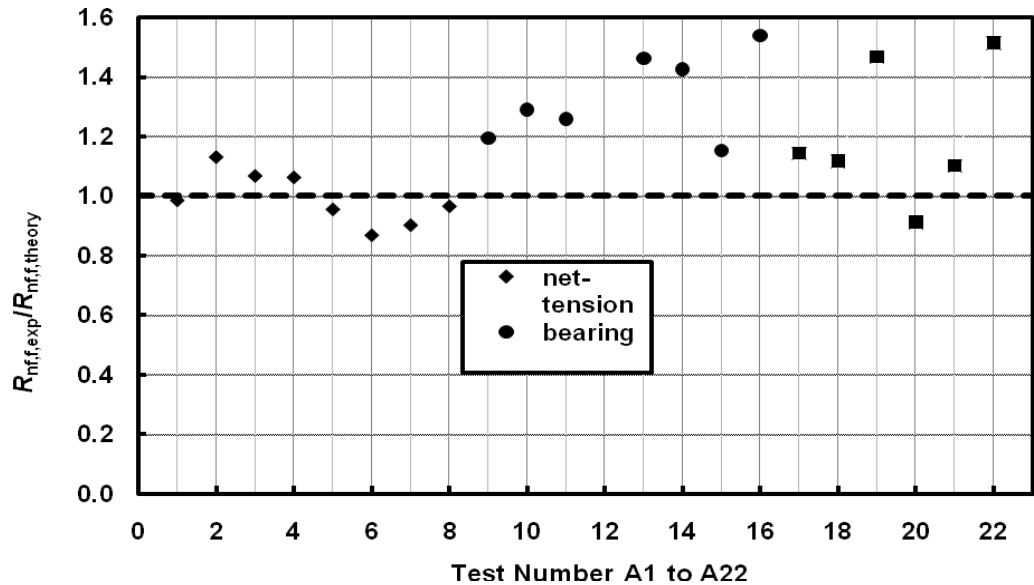

Figure C8.5. Ratio of experimental strength to predicted strength using strength formulae in Section 8.3.2 for single bolted connections and the 22 test results from Rosner and Rizkalla (1995).

C8.3.2.1 Tension and Shear Strength of Bolts

This sub-section deals with the resistance of the bolt(s) in a connection that may fail in shear, tension or a combination of both (see Figures C8.3(a) and C8.3(b)). Because the only material for bolts is steel, Equations 8.3.2-1 and 8.3.2-2 are taken from AISC (2005), in which sub-section CJ3.7 is the commentary to this provision for combined tension and shear in bolts. It has been assumed that the connecting plies do not include fillers or shims; their presence will reduce steel bolt nominal strengths in tension and shear (AISC 2005). Because thread directly bearing on FRP material may cause local material failure that will be susceptible to further deterioration in the long-term the strength formulae in Section 8.3.2-1 are for the situation where thread is excluded from the shear plane. When the designer has verification that a bolted connection, with thread not excluded from the shear plane, is to be satisfactory over its service life (i.e. there is no durability issue) the steel bolt strength F_{nv} is to be determined as $F_{nv} = 0.5F_{nt}$.

C8.3.2.2 Tension (through-the-thickness) Strength

This mode of failure is also known as the pull-through resistance (Oppe, 2009) and can be seen to be a punching shear mode of failure. It is a failure mode when the connection force component is perpendicular to the axis of the bolting and is a potential strength when there is, for example, prying action to resist. The tension through-the-thickness strength is a FRP failure mode that is not for a connection force acting in the plane of the connection itself. Equation 8.3.2-3a is taken from the EUROCOMP book (Clarke, 1996), and is for a failure that is punching shear. This mode of failure depends on the value of the characteristic in-plane shear strength in the through-the-thickness plane of the FRP material. As this shear strength can be taken to be the characteristic in-plane shear strength F_{sh} it can be determined in accordance with ASTM D5379. Equation 8.3.2-3b is a simplification to the semi-empirical equation formulated by Oppe (2009) that accounts for the failure mode governed by delamination. Delamination is a form of failure associated with FRP materials and their relatively low through-the-thickness tensile strength and it can be thought of as the act of splitting or separating a laminated material into layers. This FRP mode of failure depends on the value of the characteristic

interlaminar shear strength that can be determined in accordance with ASTM D2344.

The lesser strength from the two equations governs for the FRP material failure mode of through-the-thickness tension due to bolt pull-through (see Figure C8.3(b)). The strength prediction from these two equations is to be compared with the actual tensile strength of the bolt, as specified from Equation 8.3.2-1.

C8.3.2.3 Bearing Strength

Bearing strength is provided as a measure of the strength of the FRP material (Figures C8.3(c)) upon which the smooth shank of the bolt bears and when there can be lateral restraint afforded by tightening of the bolting (Mottram, 2009). This strength will be lower if thread is involved in transferring the connection force by bearing (Troutman and Mosteller, 2010). Accordingly, the same FRP material bearing strengths apply; regardless of the type and size of steel bolt that will change the fastener shear strength. Chamis (1980) gives Equation 8.3.2-4 and defines the bearing strength to be the same as the relevant material compressive strength. Because this approach is not reliable the characteristic strength in Equation 8.3.2-4 is to be the characteristic pin-bearing strength, determined following ASTM D593 with the appropriate material orientation, bolt diameter, FRP thickness and hole clearance size. By definition the pin-bearing strength is obtained from Equation 8.3.2-4 with a failure load obtained when the bearing steel pin has no lateral restraint. The pin-bearing strength is to be determined from the maximum load attained and not from the 4 per cent hole elongation value specified in the D 593-02 test standard. Justification for this Chapter 8 guidance towards the determination of bearing resistance is given by Mottram (2009) and Mottram and Zafari (*to be published*).

A non-standard test method has been developed and used by Ascione *et al.* (2009) to determine the variation of pin-bearing strength as the orientation of the FRP material changes from 0 to 90 degrees. The material they characterized was flat sheet (vacuum laminated) of 10 mm thickness, and testing for bearing strength used a 20 mm diameter steel pin and a 1 mm clearance hole. Because the material composition and elastic constants of the FRP material are similar to those for structural pultruded material (Anon 2010; 2010a; 2010b) it can be assumed that the measurements are representative. Figure C8.6 presents Ascione *et al.* test results by the solid smooth curve in terms of a normalized pin-bearing strength, using the peak longitudinal ($\theta = 0$ degree) value of F_L^{br} . The equivalent dashed line curve, given by the Hankinson formula of Equation [7.1-4] in ASCE-16-95 (2005), and measured F_L^{br} and F_T^{br} , shows that the assumed ‘timber’ variation formula is not acceptable for FRP material.

Using the characteristics of the experimental curve in Figure C8.6 it was decided that for orientations of FRP material between 0 and 5 degrees the characteristic pin-bearing strength is to be F_L^{br} . For all other orientations of the connection force to the principal direction of the FRP material the characteristic pin-bearing strength is to the lower bound value, given by the transverse value (i.e. F_T^{br}).

Equation 8.3.2-4 for the pin-bearing strength may be used when, on both sides of the connection, there is a washer and either a nut or the bolt head, and the bolting is tightened to the snug-tight condition. It is known that even the modest level of lateral restraint from bolt tightening will increase the bearing strength by 25%. The justification for this standard requiring a connection’s bearing strength to be determined from Equation 8.3.2-4 with the pin-bearing strength is because viscoelastic relaxation in the through-the-thickness direction might release the bolt tension over the service life of the FRP structure (Mottram, 2005).

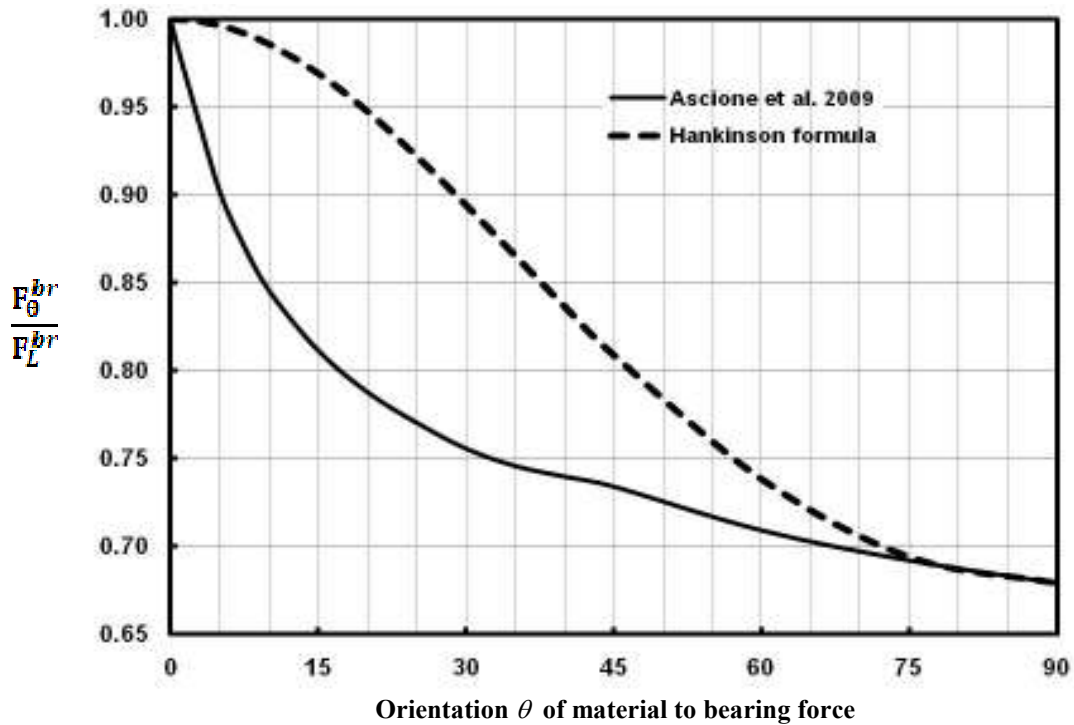

Figure C8.6. Variation of pin-bearing strength, F_{θ}^{br} , with orientation of a FRP material (Ascione *et al.*, 2009).

When making connections with, for example, a box section. it might not be practical to have a nut and washer against the inside surfaces of the closed section (as shown in Figure C8.7) and so bolt shaft flexure can develop. The existence of bolt flexure is to cause deformation along the length of the bolt that means the bearing stress is not to be uniform across the thickness of a component in the connection. For this form of closed section connection detailing, if the central void remains unfilled, it is recommended, until published test data informs otherwise, that the characteristic pin-bearing strength (either F_L^{br} or F_T^{br}) be reduced by a factor of 0.5 to take account of the non-uniform bearing pressure that will be the consequence of bolt shaft flexure.

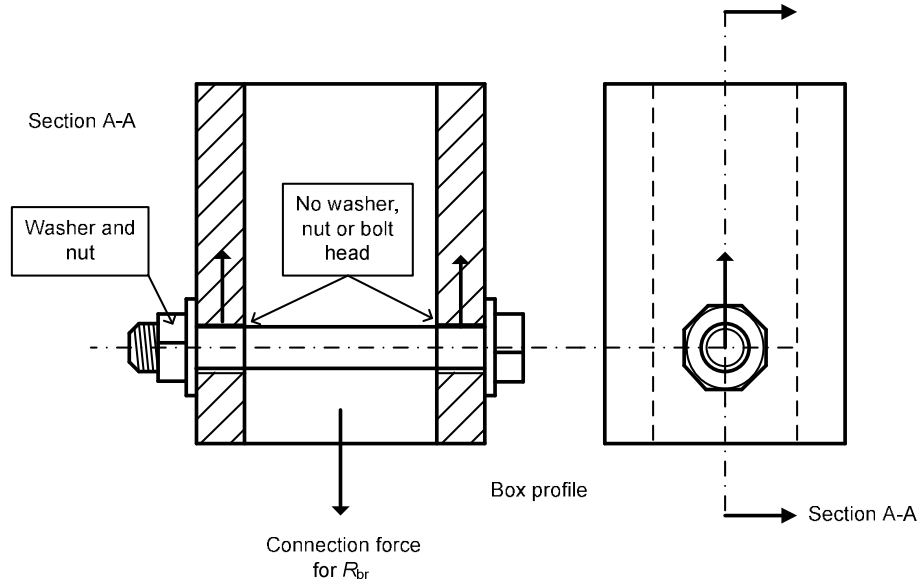

Figure C8.7. Form of closed section connection detailing when the characteristic pin-bearing strength in Equation 8.3.2-5 is to be reduced by a factor of 0.5 to account for bolt flexure.

C8.3.2.4 Net Tension Strength

The force resisted by a bearing-type connection creates a direct stress distribution across the effective width (w) of the connection component. When this force acts toward the end there is a tensile stress distribution across the net-section. This stress is not constant and has its highest value at the perimeter of the hole (Mottram, 2010). To develop closed-form equations, to calculate a connection's strength for the net tension failure mode shown in Figure C8.3(d), Hart-Smith (1987) uses the closed-form equations for the stress concentration factor (k_{te}) when the material is isotropic. He reasonably postulated a linear relationship between the required orthotropic material stress concentration factor (k_{tc}), for which there was no closed form solution, and the known isotropic stress concentration factor (k_{te}). In terms of a coefficient C (which Hart-Smith calls a correlation coefficient (1987)) the semi-empirical relationship assumed is

$$k_{tc} - 1 = C(k_{te} - 1) \quad \text{with} \quad (C8.3.2-1)$$

$$k_{te} = \frac{F_t t (w - d)}{P},$$

where

F_t = Tensile strength of material associated with the net tension plane of failure (Hart-Smith, 1987; Clarke, 1996)

w = Width of material, having constant thickness t

P = Tension load when the bolted connection fails due to the net tension mode

k_{te} = Isotropic stress concentration factor for the same joint geometry.

To determine the value of the coefficient C in Equation C8.3.2-1, the gradient is found for the plot of $k_{ic} - 1$ against $k_{ie} - 1$, using test results from single bolted connections with a range of double-lap shear connection geometries that fail in net tension. The value of coefficient C is a function of the bolt diameter-to-plate thickness ratio and the mechanical properties of the FRP material (which will also depend on the direction of connection force). If C is 1.0 the material response is perfectly brittle, and if it is zero the material is perfectly plastic in how it behaves across the net section under bearing load. Hart-Smith (1987) shows that for two laminates of two different carbon fiber reinforced epoxy materials that C is between 0.25 and 0.3. This coefficient range demonstrates that the response of these aerospace laminates is not brittle and that the bolted connections failing in net tension have a degree of damage tolerance (Mottram and Turvey, 2003).

Using their own strength measurements from 102 single-bolted connections, having three flat sheet thicknesses (i.e. 3/8 in. (9.53 mm), 1/2 in. (12.7 mm) and 3/4 in. (19 mm)) and different geometries, Rosner and Rizkalla (1995a) applied the net tension model of Hart-Smith (1987) to obtain coefficients for three orientations of the pultrusion direction. They found that C_L is 0.33 when the orientation is 0 degree (i.e. the tension load is parallel to the longitudinal direction of pultrusion) and is 0.21 and 0.25 (C_T) for the two orientations of 45 and 90 degrees. It is observed that since C has its highest value for the 0 degree situation this is the orientation that gives the lowest relative net tension strength with respect to the characteristic tensile strength of the material for that orientation. To account for the greater uncertainty in data using all relevant connections (Cooper and Turvey, 1995; Rosner and Rizkalla, 1995a; Turvey and Cooper, 1995, and Y. J. Wang 2002) that fail in net tension the standard specifies that when the pultruded material is from a shape C_L is 0.50, and when it is from plate (sometimes called flat sheet) it is 0.40. C_T is 0.50 for materials from both shapes and plates. Coefficients appropriate to other FRP material may be determined by testing in accordance with Section 2.3.2 of this standard and the guidance given by Mottram (2010).

A majority of the series of tests to characterize the strengths and modes of failure of single bolted connection have been with flat rectangular specimens of constant thickness across the width. Evernden and Pelly (2009) report test results for the tension strength of leg-angle members with a single bolt centrally placed in one of the legs. This data may be used to show that the requirements for effective width in the standard are reasonable.

The line drawings in Figure C8.8 provide illustrations, for the single bolt situation, to show how the distances e_3 and e_4 , in strength formulae 8.3.2-7a, 8.3.2-7b, 8.3.2-8a and 8.3.2-8b, are to be defined. In Figures C8.8(a) to C8.8(c) the connection force is directed perpendicular to the free edge of the connection, which is at a distance e_1 from the centre of the single hole (see Figure C8.1). This is the design situation when the direction of the connection force is acting between 0 and 5 degrees to the longitudinal direction of pultrusion. Three different geometric cases are illustrated, with Figure C8.8(a) for a flat plate of width $w = 2e_2$, Figure C8.8(b) for the case where one unloaded edge (it can be both unloaded edges) has a perpendicular (plate) element to the plane of the connection and the width of the connected component is $w = 2e_2$. Figure C8.8(c) is either for a flat plate or component with one of two perpendicular elements (not shown in illustration), giving a modeling width $w \gg 2e_2$. The same three geometric cases are shown in Figures C8.8(d) to C8.8(f) for the situation when the connection force is acting perpendicular to that for the three cases shown in Figure C8.8(a) to C8.8(c). This is the design situation when the direction of the connection force is acting between 5 and 90 degrees to the longitudinal direction of pultrusion. Note that when there are two or three bolts in the single row across the width of the connection the only change from that shown in Figures 8.8(a) to 8.8(f) is that now distances e_3 and e_4 are, respectively, defined from the centre of the two outermost bolts.

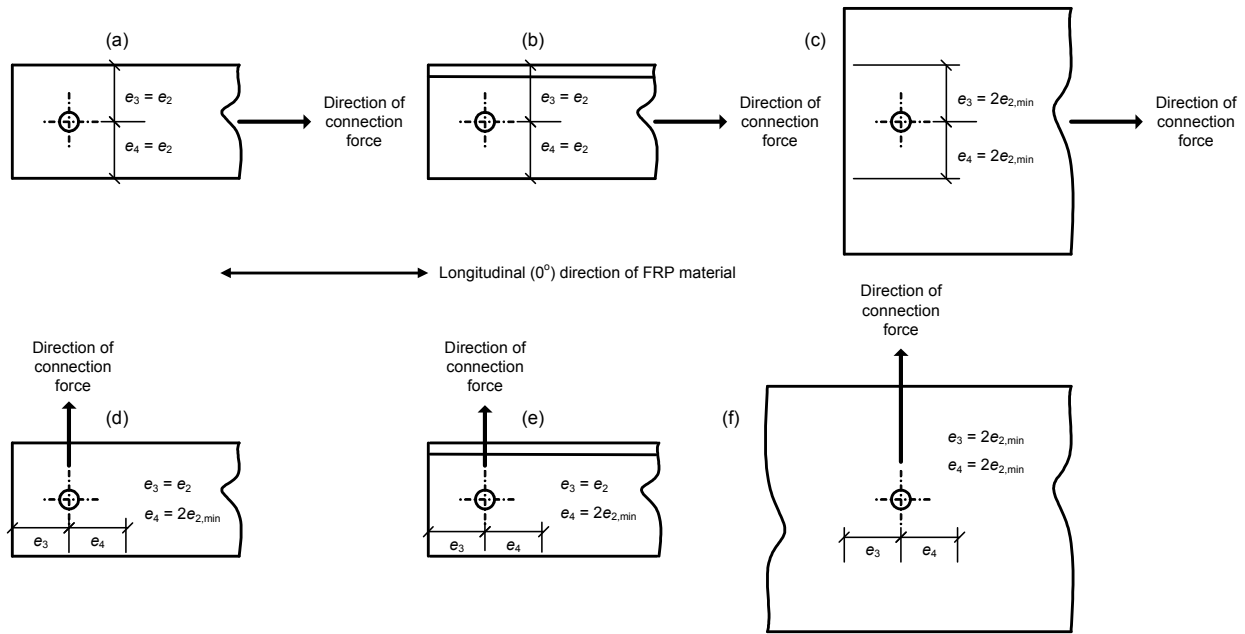

Figure C8.8. Illustrations of different connection configurations for how distances e_3 and e_4 are to be defined when the bolted connection has a single row of bolts.

C8.3.2.5 Shear-out Strength

This mode of failure is shown in Figure C8.3(e). It can occur when either the end distance ratio e_1/d is much lower than the minimum requirement in Table 8.1, or when there is a relatively high proportion of unidirectional roving reinforcement in the direction of the connection force (Clarke, 1996). Shear-out failure depends on the value of the characteristic in-plane shear strength, which is determined in accordance with ASTM D5379.

C8.3.2.6 Cleavage Strength

As shown in Figure C8.3(f) there are two possible mechanisms that have been observed for a cleavage failure. The left-sided mode is less likely to occur in a single bolted connection with the hole centrally placed. It is however more likely to occur when there is a row of two or three bolts and the edge distance e_2 is less than the gage spacing g . Strength Equation 8.3.2-10a is for this cleavage mechanism (Chamis, 1980). The right-sided mode is the one reported by Rosner and Rizkalla (1995), which lead to Equation 8.3.2-10b, being their modification to the design approach advocated by Hart-Smith (1987). As the end distance e_1 increases there is to be a transition from the cleavage to the bearing mode of failure and this is why the cleavage strength is specified to be the bearing strength when $e_1/d > 4$.

C8.3.3 Design Resistance of Multi-bolted Connections

When two or more bolt rows are positioned with pitch spacing (s) the connection force, acting in the direction of pitch, may not be distributed uniformly amongst the bolt rows (Hart-Smith, 1987; Clarke, 1996). The first row of bolts, or bolt (if each row has a single bolt), might carry, in bearing, a proportionally higher share of the connection force. The bolting at the first row, which is the furthest row away from the unloaded end of the connection component (Figure C8.2), therefore experiences much higher stress concentrations (Mottram, 2010). This is because the bearing-induced net tension stress

concentration (the stress distribution for the single-bolt connection) is combined with a net tension stress concentration created by the presence of the tension by-pass load for the unfilled hole (Hart-Smith, 1987). It is this by-pass load that provides the connection force carried by the subsequent bolt rows in bolt bearing (assuming none of the load is transferred across the contacting surfaces by frictional force).

A quirk of the multi-row configuration is that the strongest such connection which can fail in bearing, rather than tension, has only one row of bolts in it (Hart-Smith, 1987). While multi-bolted connections can be used to decrease the bearing stress, and end distance (e_1), they encourage, rather than inhibit, the occurrence of the potentially more catastrophic net tension failure mode. To this problem must be added the caveat that, since FRPs are extremely brittle materials, each hole in a multi-row bolted connection must be a nearly perfect fit to actually achieve a reduction in bearing stress rather than having all or much of the load taken by the first bolt to bottom out in its loose hole.

C8.3.3.1 Load Distribution per Bolt Row

The bolt force distributions in Table 8.3 are taken from Clarke (1996). These values are for connections with both double-lap (and single-lap) configurations. It is believed that they were obtained from static finite element analysis using a modeling methodology that assumes the identical bolts are just touching the perimeter of same sized holes (i.e. no clearance) at the onset of tension loading. The values in Table 8.3 have no provenance, but for the case of three bolt-row and FRP components they are very similar to the predictions using the analytical method from McCarthy *et al.* (2006). The load distribution between bolt rows will clearly be affected by the precise placement of the bolting in holes with clearance. The redistribution of loading that occurs with initial clearance can be investigated theoretically using the McCarthy *et al.* analysis method. Unlike ductile metals the FRP material cannot redistribute stresses that are caused by lack of fit, and so bolt placement has to be controlled when assembling FRP structures.

It can be shown that by simply adding more rows of bolts there is not going to be a significant reduction in the proportion of force taken by the first row. Accounting for the permitted steel grades and range of diameters for the bolting and FRP material of thickness not exceeding 1 in. (25.4 mm) the standard limits the number of bolt rows to three.

C8.3.3.2 Net Tension Strength at First Bolt Row

These provisions were developed by the standard writers (Mottram, 2010) based on the semi-empirical approach from Hart-Smith (1987). Net tension, if it is the key failure mode, will occur at the first row of bolting. When there are two or more bolt rows, failure is more likely to be in net tension because there may be a higher proportion of the connection force taken at the first row and the interaction of the net tension plane stress concentration factors caused by bolt bearing and bypass load (Mottram, 2010). That part of the connection force at the first row not resisted by bearing has to flow around the bolt hole(s) to be taken in bearing by the bolting in rows two, three, etc. It is this force that is the bypass load component to the connection force. Table 8.3 gives the proportions of the connection force that are to be taken for the bearing and bypass load components. The strength formulae in Section 8.3.3.2 are based on a linear interaction assumption, such that the bearing formulae in Section 8.3.2.4 (for single bolted connections) are now combined with a second term that represents the affect of the additional tensile stress concentration factor from the bypass force. If we ignore the existence of the bearing load, it is observed that the bypass loading is associated with the open-hole tensile strength of the FRP material. By using the same semi-empirical approach summarized in C8.3.2.4 the coefficient, C_{op} , for the open-hole situation can be established. The conservative value of 0.5 for both $C_{op,L}$ and $C_{op,T}$ in the standard was obtained

after evaluating the open-hole tension strength test results reported by Turvey and Wang (2003).

The coefficients are those for the situation when the connection has a single bolt. In the standard C_L is 0.50 for pultruded shapes and 0.40 for pultruded plates. C_T is 0.50 for materials from both shapes and plates. Coefficients appropriate to other FRP material may be determined by testing in accordance with Section 2.3.2 and the guidance given by Mottram (2010).

Figures C8.8 and C8.9 are plots of the ratios of the experimental strengths to those predicted using the equations in Section 8.3.3 for the distinct mode of net tension in the longitudinal (Figure C8.9) and transverse (Figure C8.10) directions. The bias factor is set to 1.0. The connection configuration in the double-lap shear tests has two bolts aligned parallel to the direction of the connection force and separated by a pitch spacing of $4.7d_n$ (d_n is the nominal hole diameter). To construct Figures C8.8 and C8.9 requires the multi-row strength results from Hassan *et al.* (1997) and the mechanical properties of the ½ in. (12.7 mm) thick pultruded material from Rosner and Rizkalla (1995). The experimental test procedure and the pultruded plate (flat sheet) materials were the same as those employed by Rosner and Rizkalla (1995). However, it is important to note that Hassan *et al.* (1997a) misinterpreted how to apply the Hart-Smith approach as they neglected to account for the stress concentrations due to both bearing and bypass loads. As a result, their analytical contribution towards the calculation of net tension strengths cannot be used. It is because Hassan *et al.* (1997a) did not involve the bypass load contribution that no open-hole strength data is available for the plate material (Rosner and Rizkalla, 1995) used in their connection tests. This issue, and others, concerning the development of the basic strength formulae in Section 8.3.3 are reported by Mottram (2010).

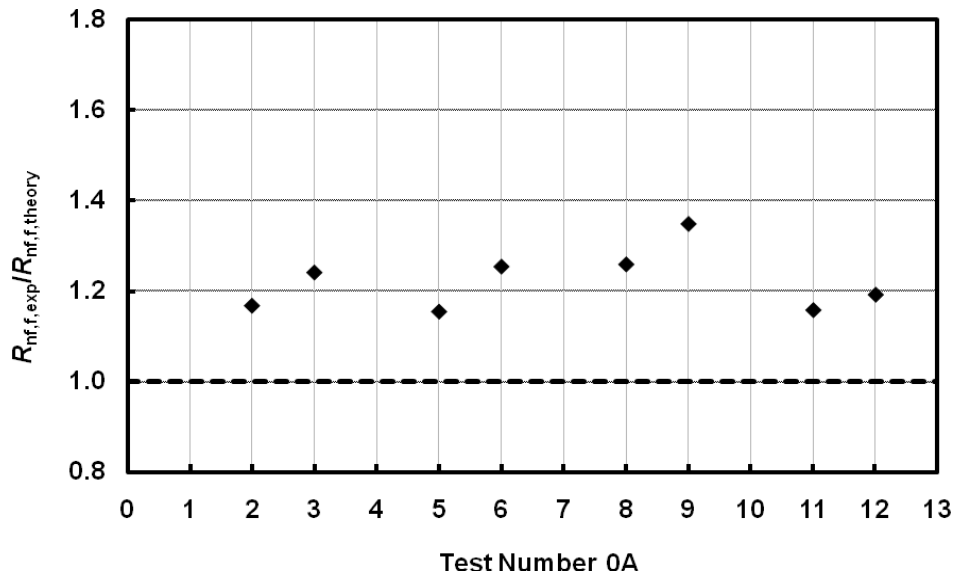

Figure C8.9. Ratios of experimental strength with predict net tension strength for multi-row bolted connections using the longitudinal material test results from Hassan *et al.* (1997) and Rosner and Rizkalla (1995) and the design formulae in Section 8.3.3.

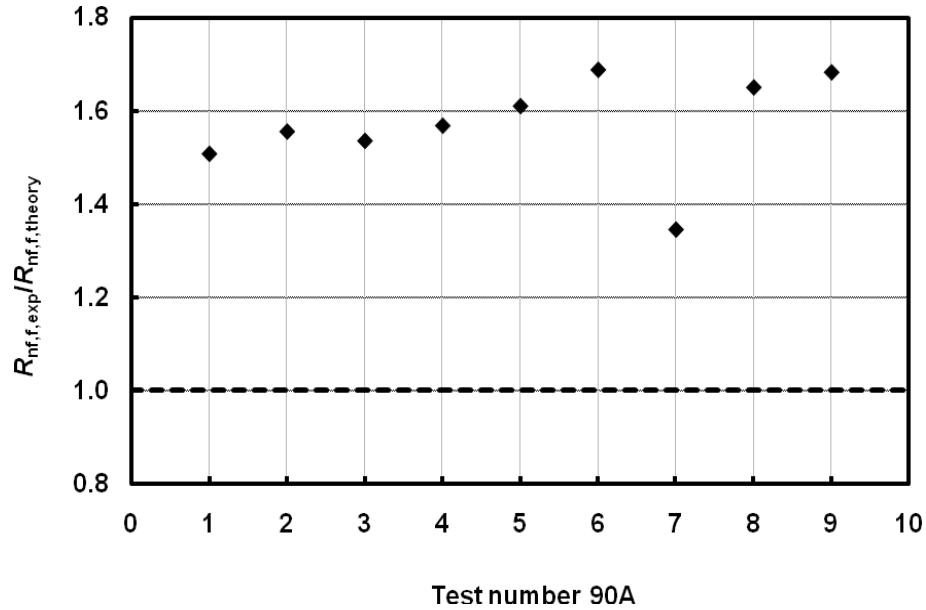

Figure C8.10. Ratios of experimental strength with predict net tension strength for multi-row bolted connections using the transverse material test results from Hassan *et al.* (1997) and Rosner and Rizkalla (1995) and the design formulae in Section 8.3.3.

For all the 22 test results in Figures C8.8 and C8.9 their ratios are well in excess of 1.0, showing that, for this multi-row connection configuration and set of test results, the determination of net tension strength is considered to be conservative when applying the provision in Section 8.3.3.

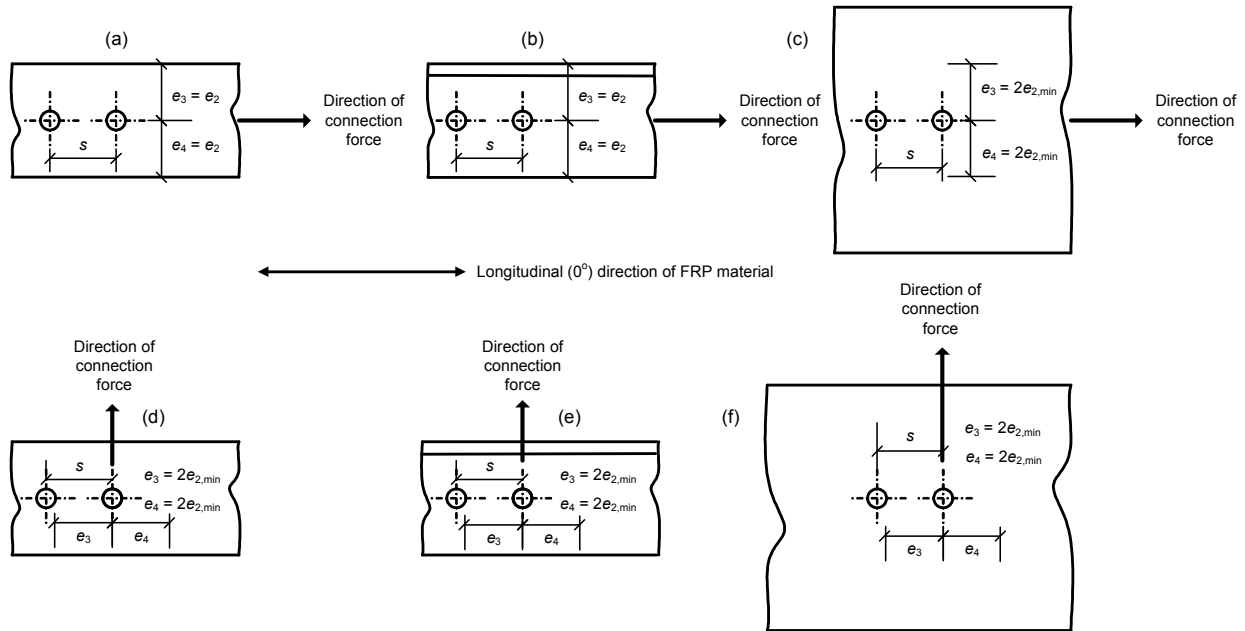

Figure C8.11. Illustrations of different connection configurations for how distances e_3 and e_4 are to be defined when the bolted connection has two or three rows of bolts.

The line drawings in Figure C8.11 provide illustrations to show how the distances e_3 and e_4 , in strength formulae 8.3.3-2a, 8.3.3-3a, 8.3.2-2b, 8.3.2-3b, 8.3.3-2c, 8.3.3-3c, 8.3.2-2d, 8.3.2-3d, are to be defined at the plane for the first row of bolts. In Figures C8.11(a) to C8.11(c) the connection force is directed normal to the free edge of the connection, which is at a distance e_1 from the centre of the hole nearest this free edge (see Figure C8.1). This is the design situation when the direction of the connection force is acting between 0 and 5 degrees to the longitudinal direction of pultrusion. Three different geometric cases are illustrated, with Figure C8.10(a) for a flat plate of width $w = 2e_2$, Figure C8.11(b) for the case where one unloaded edge (it can be both unloaded edges) has a perpendicular (plate) element to the plane of the bolted connection and the width of the connected component is $w = 2e_2$. Figure C8.11(c) is either for a flat plate or component with one of two perpendicular elements (not shown in illustration), giving a modeling width $w \gg 2e_2$. The same three geometric cases are shown in Figures C8.11(d) to C8.11(f) for the situation when the connection force is taken to be acting perpendicular to that for the three cases shown in Figure C8.11(a) to C8.11(c). This is the design situation when the direction of the connection force is acting between 5 and 90 degrees to the longitudinal direction of pultrusion. Note that when there are two or three bolts in the first row across the width of the connection the only change from that shown in Figures 8.11(a) to 8.11(f) is that now distances e_3 and e_4 are, respectively, defined from the centre of the two outermost bolts.

C8.3.3.3 Shear-out Strength between Rows of Bolts

This is an uncommon mode of failure which is unlikely to happen if the minimum geometry requirements in Table 8.1 are satisfied.

C8.3.3.4 Block Shear Strength

Prabhakaran *et al.* (1996) conducted a series of multi-row bolted double-lap shear connection tests with pultruded (plate) material and concentric loading to show that Equation 8.3.3-6a can be applied when the mode of failure is block shear. Using the AISC (2005) strength model with net cross-section areas they

made the assumption that each bolt carried an equal proportion of the connection force. As presented in Section C8.3.3.1 this assumption is known not to be exact when there are three bolt rows and all the connection components are of FRP material. For illustration purposes only Figure C8.12 shows several different block shear loading situations (taken from Owen and Cheal, 1989). The hashed areas in the four illustrations show the assumed direct stress distributions at the failure plane. Such situations with FRP components may require stiffening details. An example of the fracture path for this mode of failure is shown in Figure C8.3(h) and three concentric load cases are shown in the lower part to Figure C8.12.

Equation 8.3.3-6b is also from AISC (2005) and is for the situation where there is an eccentric connection force. Such a loading is illustrated in the upper part to Figure C8.12. It has the addition of a 0.5 reduction factor to its tensile resistance component. For pultruded connections there are no test results for the design situation where Equation 8.3.3-6b is to apply. It is for this reason that testing has to be used to verify the design.

Block shear failure is known to occur when the bolt arrangement is staggered (Prabhakaran *et al.*, 1996). The provisions for the determining the net area subjected to tension are based on the approach used with steel (AISC, 2005) and aluminum (BS EN1999-1-1, 2007). For pultruded connections it is possible that not all modes of failure have been identified when bolting has a staggered arrangement. It is for this reason that when bolting is staggered and loading is eccentric testing has to be involved in the process to verify new designs.

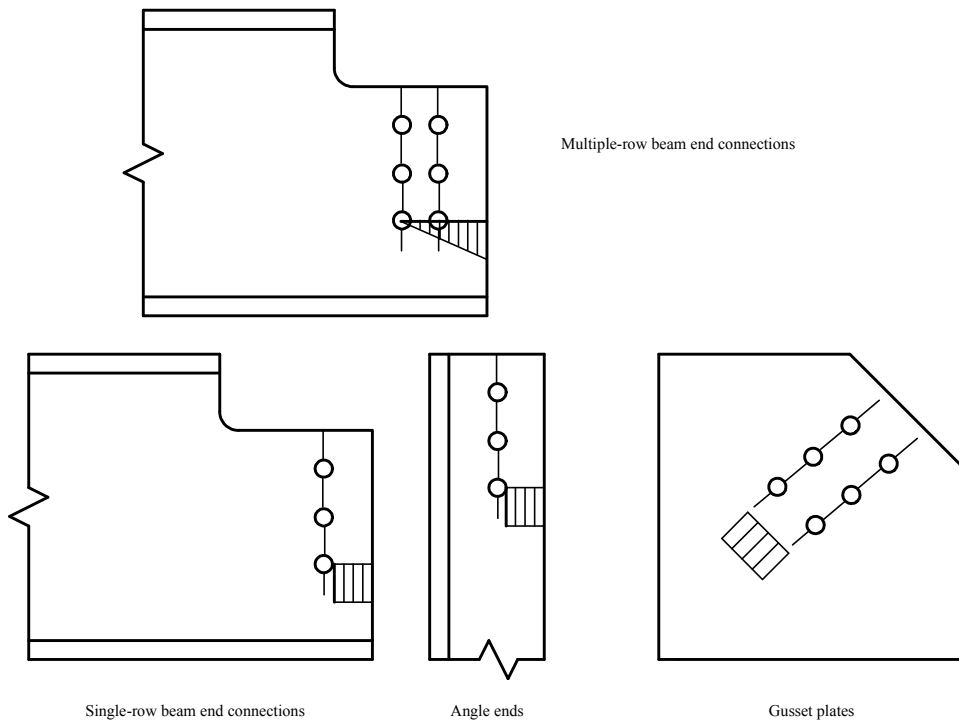

Figure C8.12. Block shear loading situations with assumed direct stress distributions.

C8.3.4 Frame Connections

Moment connections are difficult to achieve in practice in FRP structures. Because of a lack of experimental data on moment connections all beam-column (Mottram and Zheng, 1997a; Turvey and

Cooper, 2004) column-base, and beam splice connections that classify as moment resistant are not covered in this standard. In this standard the definition of a moment connection is taken as follows. Moment connections are designed to transfer appreciable bending moments, shear forces and sometimes axial force. The design strength and design stiffness of a moment connection are defined in relation to the strength and stiffness of the connected members. The design strength of a moment connection may be full-strength (i.e. the moment capacity of the connection is equal to or large than the capacity of the connected member) or partial-strength (i.e. the moment capacity of the connection is less than that of the connected member). Similarly the stiffness of a moment connection can be rigid or semi-rigid compared to the stiffness of the connected member. Frame connections scoped by the provisions in this standard are for simple connections (Anon, 2010b, Mottram and Zheng, 1997) that are to be designed to only transfer an appreciable shear force and sometimes axial force. It is assume that the bending moment transmitted by a pinned connection is low enough for it not to affect the design.

C8.3.4.1 Simple framing Connections

A nominally pinned connection can be achieved in practice using shear-plate (clip angle) elements of pultruded FRP material (Anon, 2010; 2010a; 2010b). It must be designed and been pre-qualified by testing to be capable of transmitting the internal forces, without developing any significant moment that might, by prying action, adversely affect the FRP clips, the FRP members or the structure as a whole during the service life (Clarke, 1996; Zheng and Mottram, 1997). Because analysis of prying action is known to be difficult with the more amenable simple connections in steel structures (Owen and Cheal, 1989), it is not possible to have a close form formula for the end rotation capacity when FRP clip angles start to fail at the instep of the leg-angle component (Zheng and Mottram, 1997).

The reasons for the difficultly with steel are;

- a. the significance of imperfections and fit on the distribution of (prying) forces
- b. the assessment of true bolt stiffness
- c. uncertainty of distribution of bearing between bolt head and 'end' plate
- d. local through-thickness effects in the vicinity of the bolt holes.

Design with FRP is made more difficult because of shear deformation, the uncertainty in knowing the through-the-thickness mechanical properties and the observed mode of failure in the clip angles is delamination caused by a through-the-thickness stress field that cannot be accurately quantified.

Oppe (2008) and Oppe and Knippers (2009) have proposed a formula that can be used to check for the strength of the flange-web junction of, say, a column member due to the tension action from prying action of a shear-plate. This formula is not in the standard because testing to verify its performance is not sufficient at this time.

C8.3.4.1.1 Shear Strength of Clip Angle

If the clip element is of FRP material its failure may be due to the shear force exceeding the shear strength along the shear plane at the knee of the clip angle. When there are two web shear planes it is assumed that shear force to be transmitted through the simple frame connection is equally distributed between them. The model used to formulate the sizing Equation 8.3.3-7 is given in Figure C8.13.

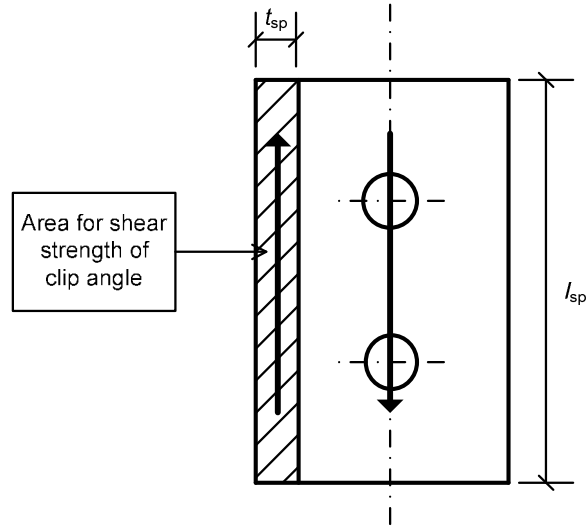

Figure C8.13. Area resisting shear force in clip angle for simple connection.

C8.3.4.2 Compression Members with Bearing Connections

The general provision is in accordance with AISC (2005).

C8.3.4.3 Column Bases and Bearing on Concrete

The provisions of this section are identical to equivalent provisions in ACI 318 (ACI, 2008).

Because of the lower rotation capacity required of a column base connection it can have both web and flange clip elements and possess a rotation capable of accepting the resulting rotation under design loads (Turvey and Cooper, 1998).

References

ACI. (2008), *Building Code Requirements for Structural Concrete*, ACI Committee 318, ACI 318-08, American Concrete Institute, Farmington Hills, MI.

Anon. (2010), *Bedford Design Guide*, Bedford Reinforced Plastics, Inc., Bedford, PA. <http://www.bedfordplastics.com/aboutfrp.htm> (Literature library) 1st July 2010.

Anon. (2010a), *The New and Improved Pultrex® Pultrusion Design Manual (Imperial Version)*, Creative Pultrusions, Inc., Alum Bank, PA. <http://www.creativepultrusions.com/rd.html> (Literature library) 1st July 2010.

Anon. (2010b), *Strongwell Design Manual* Strongwell, Bristol, VA. <http://www.strongwell.com/> (Literature) 1st July 2010.

Anon. (2011), *Code of Standard Practice for Fabrication and Installation of Pultruded FRP Structures*, Pultrusion Industry Council (PIC), American Composites Manufacturers Association (ACMA), Arlington, VA. (draft)

AISC. (2005), *Specification for Structural Steel Buildings and Commentary*, ANSI/AISC 360-05, American Institute of Steel Construction, Chicago.

ASCE. (1995), *Standard for Load and Resistance Factor Design (LRFD) for Engineered Wood Construction*, AF&PA/ASCE 16-95, American Society of Civil Engineers, Reston, VA.

Ascione, F., Feo, L. and Maceri, F. (2009), An Experimental Investigation on the Bearing Failure Load of Glass Fibre/Epoxy Laminates, *Composites: Part B*, 40 3, 197-205.

ASTM A307-07b. (2007), *Standard Specification for Carbon Steel Bolts and Studs, 60 000 PSI Tensile Strength*, ASTM International, West Conshohocken, Pa.

ASTM A325-09. (2009), *Standard Specification for Structural Bolts, Steel, Heat Treated, 120/105 ksi Minimum Tensile Strength*, ASTM International, West Conshohocken, Pa.

ASTM A490-10. (2010), *Standard Specification for Structural Bolts, Alloy Steel, Heat Treated, 150 ksi Minimum Tensile Strength*, ASTM International, West Conshohocken, Pa.

ASTM A563-07a, (2007), *Standard Specification for Carbons and Alloy Steel Nuts*, ASTM International, West Conshohocken, Pa.

ASTM D953-10. (2010), *Standard Test Method for Bearing Strength of Plastics*, ASTM International, West Conshohocken, Pa.

ASTM D2344 / D2344M - 00(2006). (2006), *Standard Test Method for Short-Beam Strength of Polymer Matrix Composite Materials and Their Laminates*, ASTM International, West Conshohocken, Pa.

ASTM D5379 / D5379M – 05. (2005), *Standard Test Method for Shear Properties of Composite Materials by the V-Notched Beam Method*, ASTM International, West Conshohocken, Pa.

ASTM F436-10. (2010), *Standard Specification for Hardened Steel Washers*, West Conshohocken, Pa.

ASTM F593-02. (2008), *Standard Specification for Stainless Steel Bolts, Hex Cap Screws, and Studs*, ASTM International, West Conshohocken, Pa.

ASTM F594-09. (2009). *Standard Specification for Stainless Steel Nuts*, ASTM International, West Conshohocken, Pa.

ASTM F844-07a. (2007). *Standard Specification for Washers, Steel, Plain (Flat), Unhardened for General Use*, ASTM International, West Conshohocken, Pa.

Bank, L. C. (2006), *Composites for Construction - Structural Design with FRP Materials*, John Wiley & Sons, New Jersey, 2006.

BS EN 1993-1-8:2005. (2005), *Eurocode 3: Design of Steel Structures. Part 1-8: Design of Joints*, British Standards Institute (BSi), London, UK.

BS EN 1999-1-1:2007. (2007), *Eurocode 9: Design of Aluminium Structures. Part 1-1: General Structural Rules*, British Standards Institute (BSi), London, UK.

Chamis, C. C. (1980), *Simplified Procedures for Designing Composite Bolted Joints*, Forty-third Annual Conference on Fibrous Composites in Structural Design, San Diego, California, November 1978, New York, Plenum Press, 652-657.

Clarke, J. L. (Ed.). (1996), *Structural Design of Polymer Composites, Eurocomp Design Code and Handbook*, E&FN Spon, London.

Cooper, C. and Turvey, G. J. (1995), Effects of Joint Geometry and Bolt Torque on the Structural Performance of Single-bolt Tension Joints in Pultruded GRP Sheet Material *Composite Structures*, 32 (1-4), 217-226.

Erki, M. A. (1995), Bolted Glass-fibre-reinforced Plastic Joints, *Canadian Journal of Civil Engineering*, 22 4, 736-744.

Evernden M. and Pelly R. J. (2009), *Single Bolt Tension Joints in Pultruded PFRP Leg-angle Connections*, Proceedings Fourth International Conference on Advanced Composites in Construction (ACIC 2009), NetComposites, Chesterfield, UK, 473-482.

Hart-Smith, L. J. (1987), *Mechanically-fastened Joints for Advanced Composites - Phenomenological Considerations and Simple Analyses*, Fourth Conference on Fibrous Composites in Structural Design, Plenum, New York, 543-574.

Hassan, N. K., Mohamedien, M. A. and Rizkalla, S. H. (1997), Multibolted Joints for GFRP Structural Members *Journal of Composites for Construction*, 1 1, 3-6.

Hassan, N. K., Mohamedien, M. A. and Rizkalla, S. H. (1997a), Rational Model for Multibolted Connections for GFRP Members, *Journal of Composites for Construction*, 1 2, 71-78.

Lutz, C. (2005), *Structural Integrity of Bolted Joints for PFRP Profiles*, PhD thesis, University of Warwick, UK.

McCarthy, M. A., McCarthy, C. T. and Padhi, G. S. (2006), A Simple Method for Determining the Effects of Bolt-hole Clearance on Load Distribution in Single-column Multi-bolt Composite Joints, *Composite Structures*, 73 1, 78-81.

Mottram, J. T. and Zheng, Y. (1999), Further Tests on Beam-to-column Connections for Pultruded Frames: Web-cleated, *Journal of Composites for Construction*, 3 1, 3-11.

Mottram, J. T. and Zheng, Y. (1999a), Further Tests on Beam-to-column Connections for Pultruded Frames: Flange-cleated, *Journal of Composites for Construction*, 3 3, 108-116.

Mottram, J. T. and Turvey G. J. (2003), Physical Test Data for the Appraisal of Design Procedures for

Bolted Joints in Pultruded FRP Structural Shapes and Systems, *Progress in Structural Engineering and Materials*, 5 4, 195-222.

Mottram, J. T. (2005), *Friction and Load Transfer in Bolted Joints of Pultruded Fibre Reinforced Polymer Section*, Second International Conference on FRP Composites in Civil Engineering, Taylor & Francis Group, London, 845-850.

Mottram, J. T. (2009), *Determination of Pin-bearing Strength for the Design of Bolted Connections with Standard Pultruded Profiles*, Proceedings Fourth International Conference on Advanced Composites in Construction, NetComposites, Chesterfield, UK, 483-495.

Mottram, J. T. (2010), Prediction of Net-tension Strength for Multi-row Bolted Connections of Pultruded Material using the Hart-Smith Semi-empirical Modeling Approach, *Journal of Composites for Construction*, 14 1,105-114.

Mottram, J. T. and Zafari, B. (?), Pin-Bearing Strengths for Design of Bolted Connections in Pultruded Structures, *Structures and Buildings*, (in review, to be published before this standard goes to print)

Oppe, M. (2009), *Zur Bemessung geschraubter Verbindungen von pultrudierten faserverstärkten Polymerprofilen*, PhD thesis, University of Aachen, 2009. (in German)

Oppe, M. and Knippers, J. (2009), *Behaviour of Bolted Connections in GFRP Subjected to Tension Loads*, Proceedings Fourth International Conference on Advanced Composites in Construction (ACIC 2009), NetComposites, Chesterfield, UK, 495-506.

Owen, G. W. and Cheal, B. D. (1989), *Structural Steelwork Connections*, Butterworth-Heinemann, London.

Prabhakaran, R., Razzaq, Z. and Devara, S. (1996), Load and Resistance Factor Design (LRFD) Approach for Bolted Joints in Pultruded Composites, *Composites - Part B: Engineering*, 27 3-4, 351-360.

Prabhakaran, R. and Robertson, J. (1998), *An Experimental Investigation of Load-sharing in a Multi-bolt Pultruded Composite Joint*, Second International Conference on Composites in Infrastructure, University of Arizona, Tuscon, Arizona, Vol. II, 355-368.

Rosner, C. N. and Rizkalla, S. H. (1995), Bolted Connections for Fiber-reinforced Composite Structural Materials: Experimental Program, *Journal of Materials in Civil Engineering*, 7 4, 223-231.

Rosner, C. N. and Rizkalla, S. H. (1995a), Bolted Connections for Fiber-reinforced Composite Structural Members: Analytical Model and Design Recommendations, *Journal of Materials in Civil Engineering*, 7 4, 232-238.

Steffen, R. E. (1998), *Behavior and Design of Fiber-reinforced Polymeric Composite Equal-leg Struts*, PhD thesis, Georgia Institute of Technology, Atlanta, Georgia, USA.

Troutman, D. and Mosteller, J. (2010). *An Investigation of Pin Bearing Strength on Composite Materials*, Proceedings of 2010 CTI (Cooling Tower Institute) Annual Conference, Houston, Texas 77056, February, Paper No. TP10-24, pp. 8.

- Turvey, G. J. and Cooper, C. (1995), *Single Bolt Tension Joint Tests on Pultruded GRP WF-Section Web and Flange Material*, Tenth International Conference on Composite Materials, Woodhead Publishing, Vol. III, 621-628.
- Turvey, G. J. (1998), Single-bolt Tension on Pultruded GRP Plate – Effect of Tension Direction Relative to Pultrusion Direction, *Composite Structures*, 42 4, 341-351.
- Turvey, G. J. and Cooper, C. (1998), *Uplift tests on column base connections in pultruded GRP frames*, Eighth European Conference on Composite Materials, Woodhead Publishing Ltd., Cambridge, Vol. 2, 285-292.
- Turvey, G. J. (2000), Bolted Connections in PFRP Structures, *Progress in Structural Engineering and Materials*, 2 2, 146-156.
- Turvey, G. J. and Wang, P. (2003), Open-hole Tension Strength of Pultruded GRP Plates, *Structures and Buildings*, 156 1, 93-101.
- Turvey, G. J. and Cooper, C. (2004), Review of Tests on Bolted Joints between Pultruded GRP Profiles, *Structures and Buildings*, 157 3, 211-233.
- Turvey, G. J. and Wang, P. (2007), Thermal Preconditioning Study for Bolted Tension Joints in Pultruded GRP plate, *Composite Structures*, 77 4, 509-513.
- Turvey, G. J. and Wang, P. (2007a), Failure of Pultruded GRP Single-bolt Tension Joints Under Hot-wet Conditions, *Composite Structures*, 77 4, 514-520.
- Turvey, G. J. and Wang, P. (2009), *Failure of Pultruded GRP Angle-leg Junctions in Tension*, Proceedings on Seventeenth International Conference on Composite Materials (ICCM-17), 27th-31st July, IoM³ DVD, Paper A1:1 pg. 11.
- Wang, Y. J. (2002), Bearing Behavior of Joints in Pultruded Composites, *Journal of Composite Materials*, 36 18, 2199-2216.
- Wang, P. (2004), *Structural Integrity of Bolted Joints for Pultruded GRP Profiles*, PhD Thesis, University of Lancaster, UK.
- Yuan, R. L., Liu, C. J. and Daley, T. (1996), *Study of Mechanical Connection for GFRP Laminated Structures*, Second International Conference on Advanced Composite Materials in Bridges and Structures, Canadian Society of Civil Engineers, Montreal, 951-958.
- Yuan, R. L. and Liu, C. J. (2000), *Experimental Characterization of FRP Mechanical Connection*, Third International Conference on Advanced Composite Materials in Bridges and Structures, Canadian Society of Civil Engineers, Montreal, 103-110.